

---

SECTION 1

**SERVICE MANUAL**

TABLE OF CONTENTS

I. TECHNICAL DATA .....	2
II. DISMANTLING OF UNIT .....	3
III. CONTROLS .....	4
IV. PRINCIPAL PARTS LOCATION .....	5
V. LEVEL DIAGRAM .....	6
VI. MAIN AMPLIFIER ADJUSTMENT .....	7
VII. CLASSIFICATION OF VARIOUS P.C BOARDS .....	8
1. RELATION OF P.C BOARD TITLE AND IDENTIFICATION NUMBER .	8
2. COMPOSITION OF VARIOUS P.C BOARDS .....	9

For basic adjustments, measuring methods, and operating principles, refer to GENERAL OPERATING PRINCIPLES AND ADJUSTMENTS.

# I. TECHNICAL DATA

## POWER AMPLIFIER SECTION

CONTINUOUS POWER OUTPUT 2-CHANNELS DRIVEN		40 watts per channel, minimum RMS, at 8 ohms from 20 to 20,000 Hz with no more than 0.15% total harmonic distortion.
POWER BANDWIDTH (IHF)		7 Hz to 40 kHz/8 ohms (Total Harmonic Distortion: 0.15%)
SIGNAL TO NOISE RATIO (IHF)	PHONO	Better than 75 dB
	AUX	Better than 95 dB
RESIDUAL NOISE		Less than 0.5 mV at 8 ohms
CHANNEL SEPARATION (IHF)	PHONO	Better than 55 dB at 1,000 Hz
DAMPING FACTOR		More than 60 (1 kHz, 8 ohms)
OUTPUT	SPEAKERS	A, B (4 to 16 ohms)/A+B (8 to 16 ohms)
	HEADPHONE	4 to 16 ohms

## PREAMPLIFIER SECTION

INPUT SENSITIVITY/IMPEDANCE	PHONO	3 mV/50 k ohms
	AUX	150 mV/100 k ohms
	TUNER	150 mV/100 k ohms
	TAPE MONITOR	PIN: 150 mV/100 k ohms DIN: 150 mV/100 k ohms
OUTPUT LEVEL/IMPEDANCE	TAPE REC	PIN: 150 mV/100 k ohms DIN: 30 mV/180 k ohms
FREQUENCY RESPONSE		
	PHONO (RIAA EQUALIZATION)	30 Hz to 15 kHz +1 dB, -1 dB
	TUNER, AUX, TAPE MONITOR	7 Hz to 70 kHz +0 dB, -1 dB
TONE CONTROL	BASS	±9 dB at 100 Hz (400 Hz position), ±6 dB at 100 Hz (200 Hz position)
	TREBLE	±9 dB at 10 kHz (2.5 kHz position), ±6 dB at 100 Hz (5 kHz position)
LOUDNESS CONTROL		+10 dB at 100 Hz, +6 dB at 10 kHz (Volume control set at -30 dB position)
FILTER	HIGH	-3 dB at 10 kHz
	LOW	-3 dB at 30 Hz

## MISCELLANEOUS

SEMI-CONDUCTORS	Transistors: 33, Diodes: 15
POWER REQUIREMENTS	CSA, LA and LA Models: 120V, 60 Hz CEE Models: 220V, 50 Hz Other Models: 110/220/240V, 50/60 Hz Switchable
DIMENSIONS	440(W) × 141(H) × 331(D) mm (17.3" × 5.6" × 13")
WEIGHT	9.1 kg (20 lbs)

\* For improvement purposes, specifications and design are subject to change without notice.

## II. DISMANTLING OF UNIT

In case of trouble, etc. necessitating disassembly, please disassemble in the order shown in photographs. Reassemble in reverse order.

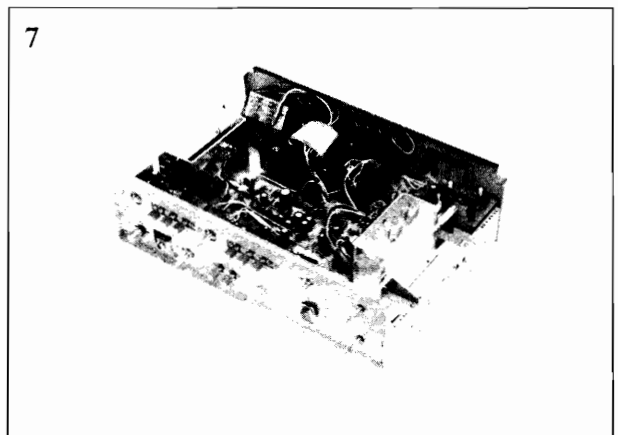
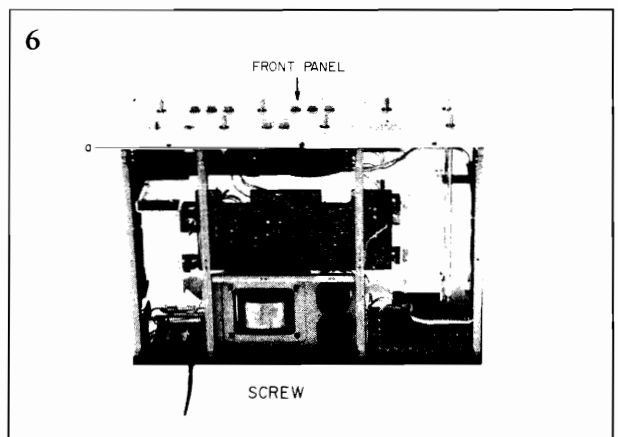
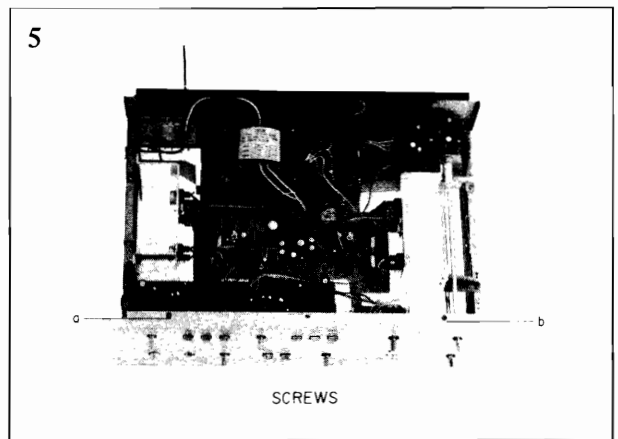
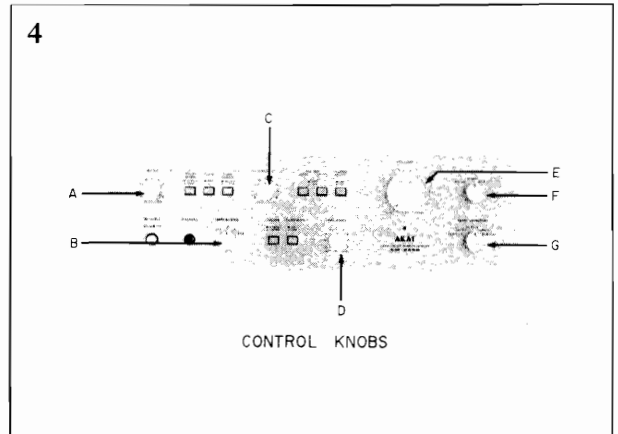
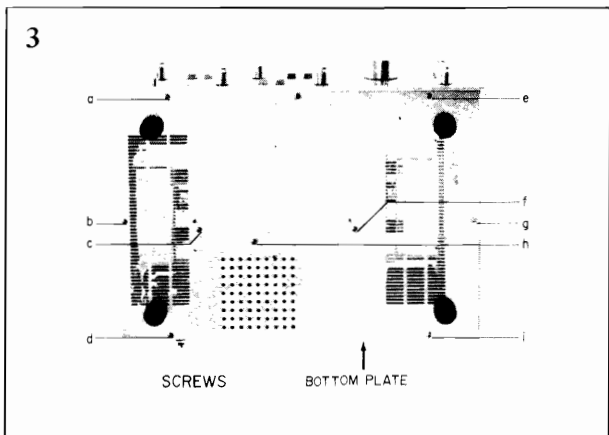
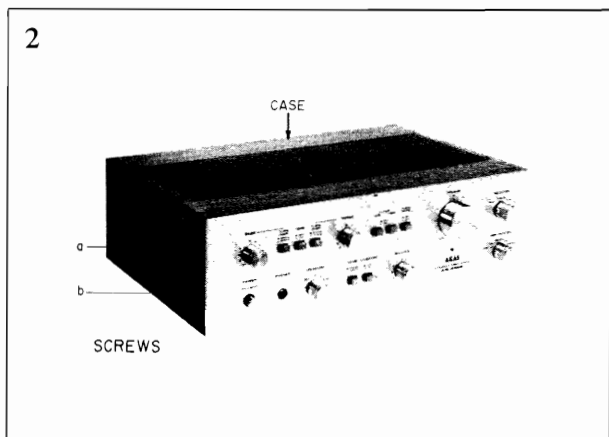
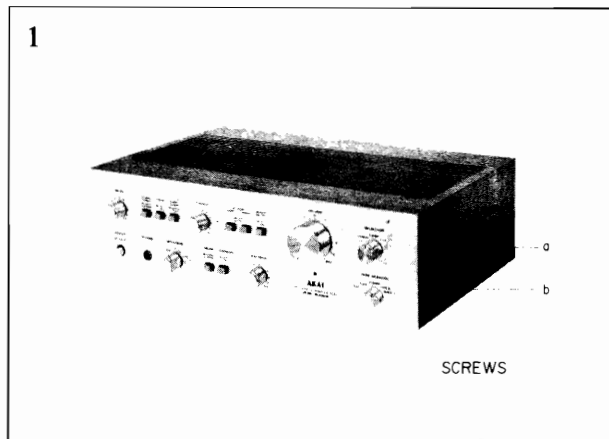

### III. CONTROLS

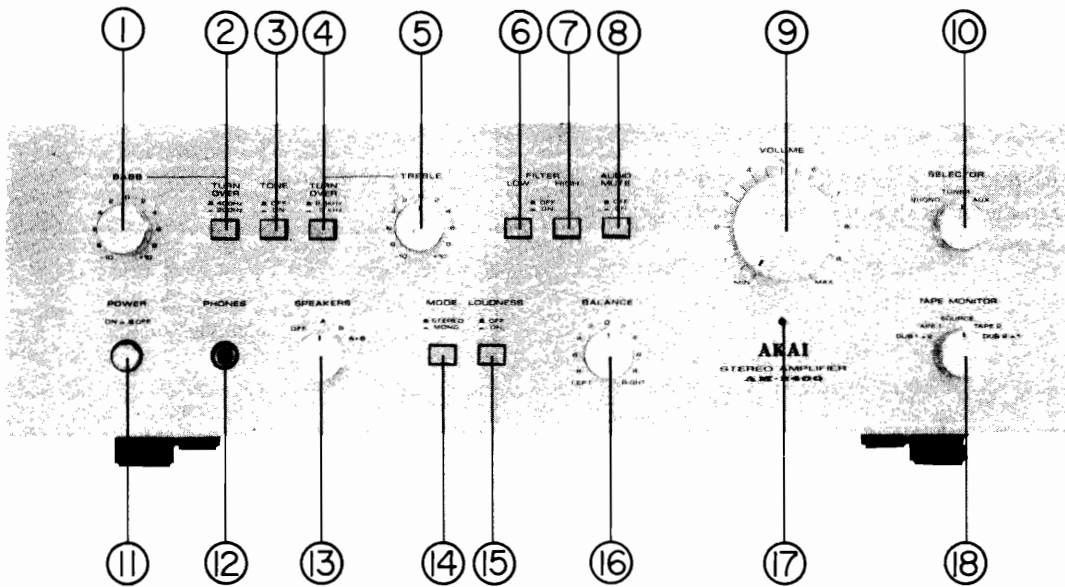

Fig. 1 Controls

- |                                   |                             |
|-----------------------------------|-----------------------------|
| 1. BASS TONE CONTROL              | 10. INPUT SELECTOR          |
| 2. BASS CONTROL TURNOVER SWITCH   | 11. POWER SWITCH            |
| 3. TONE SWITCH                    | 12. HEADPHONE               |
| 4. TREBLE CONTROL TURNOVER SWITCH | 13. SPEAKER SYSTEM SELECTOR |
| 5. TREBLE TONE CONTROL            | 14. MODE                    |
| 6. LOW FILTER                     | 15. LOUDNESS                |
| 7. HIGH FILTER                    | 16. STEREO BALANCE CONTROL  |
| 8. AUDIO MUTE                     | 17. POWER INDICATOR         |
| 9. VOLUME CONTROL                 | 18. TAPE MONITOR            |

# IV. PRINCIPAL PARTS LOCATION

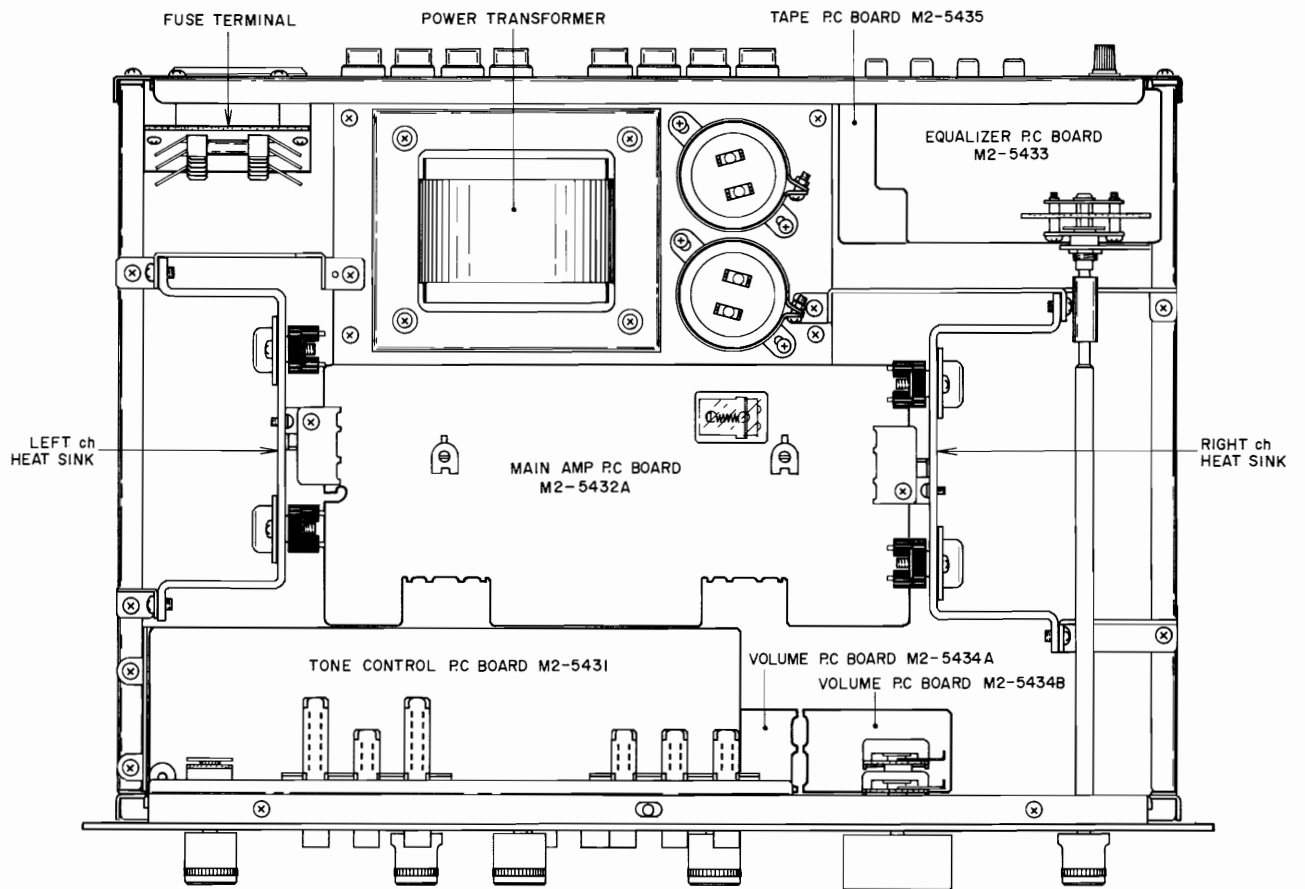

Fig. 2 Top View

# V. LEVEL DIAGRAM

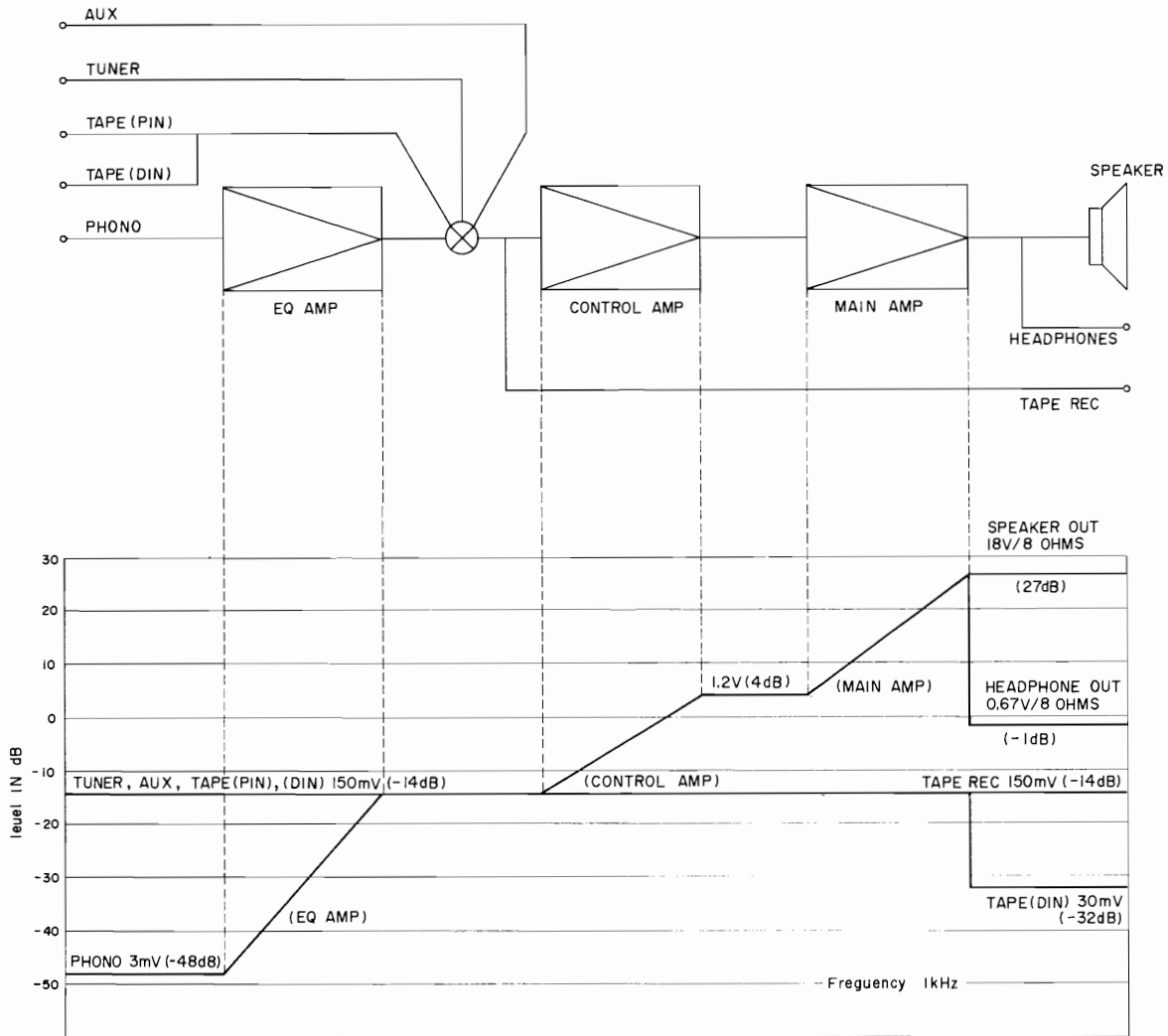

Fig. 3 LEVEL Diagram of Model AM-2400

## VI. MAIN AMPLIFIER ADJUSTMENT

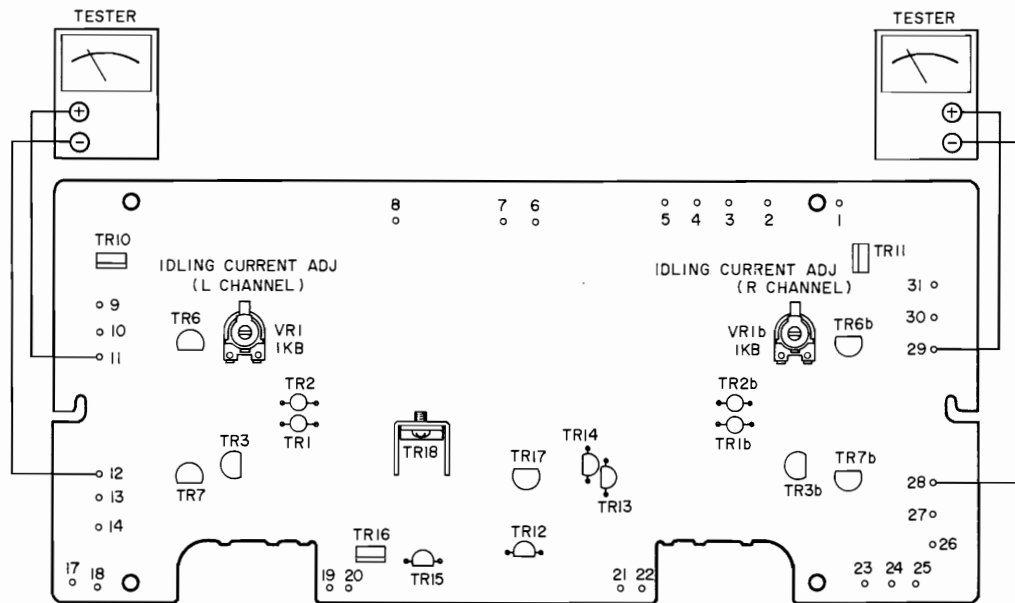

Fig. 4 Main Amplifier P.C Board M2-5432A

### Idling Current Adjustment

Connect a tester to Main Amplifier P.C Board test point between PIN-11 and PIN-12 (LEFT channel) and PIN-28 and PIN-29 (RIGHT channel).

Adjust semi-fixed resistors VR1, VR1b until the voltage is 30 mV.

## VII. CLASSIFICATION OF VARIOUS P.C BOARDS

---

### 1. RELATION OF P.C BOARD TITLE AND IDENTIFICATION NUMBER

P.C Board	Number of P.C Board
Tone Control P.C Board	M2-5431
Main Amp P.C Board	M2-5432A
Temp Compensation P.C Board	M2-5432B
Temp Compensation P.C Board	M2-5432C
EQ P.C Board	M2-5433
LED P.C Board	M2-5433A
Volume P.C Board A	M2-5434A
Volume P.C Board B	M2-5434B
Tape P.C Board	M2-5435



## 2. COMPOSITION OF VARIOUS P.C BOARDS

### 1) TONE CONTROL P.C BOARD M2-5431

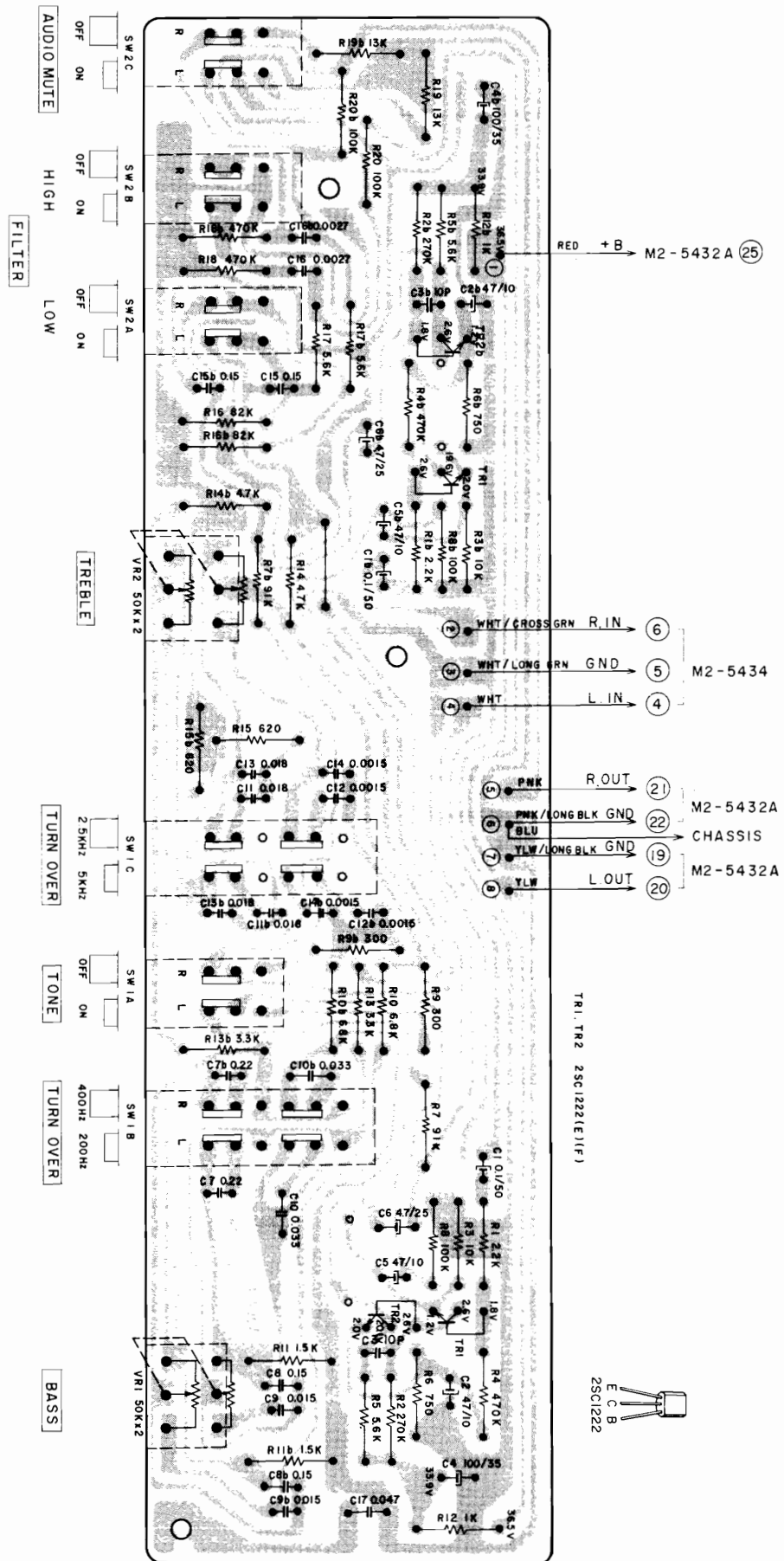



3) EQ P.C BOARD M2-5433

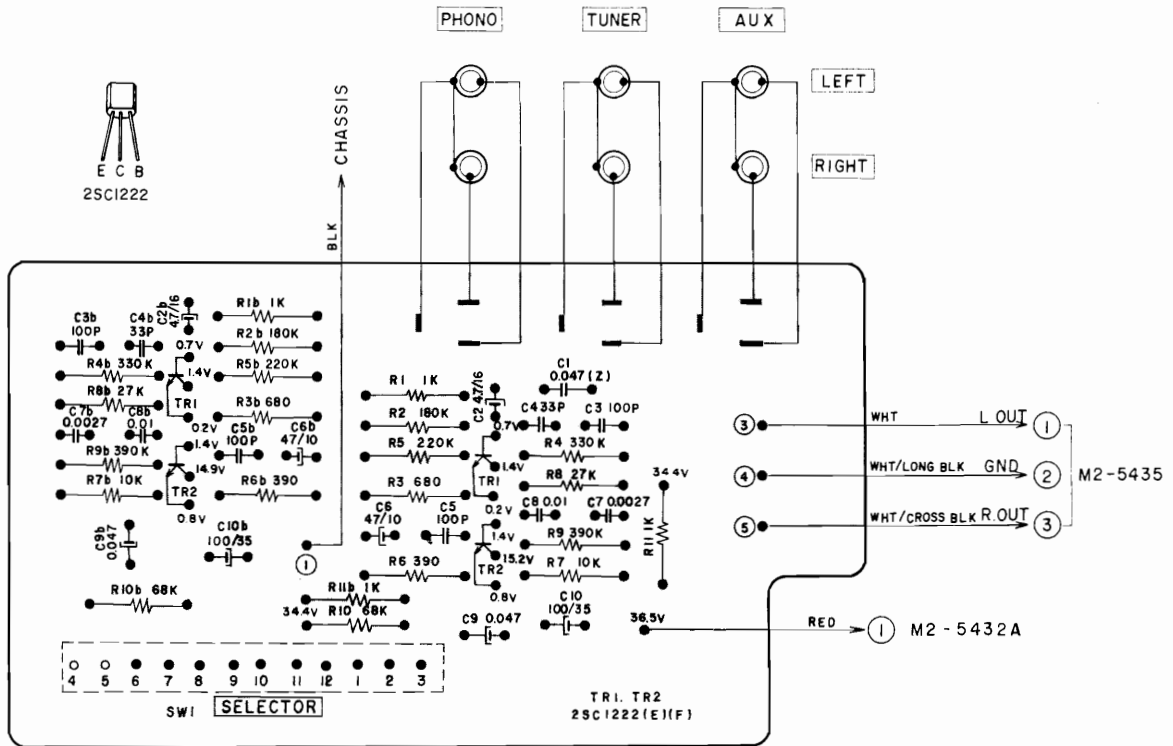

4) VOLUME P.C BOARD M2-5434A, M2-5434B

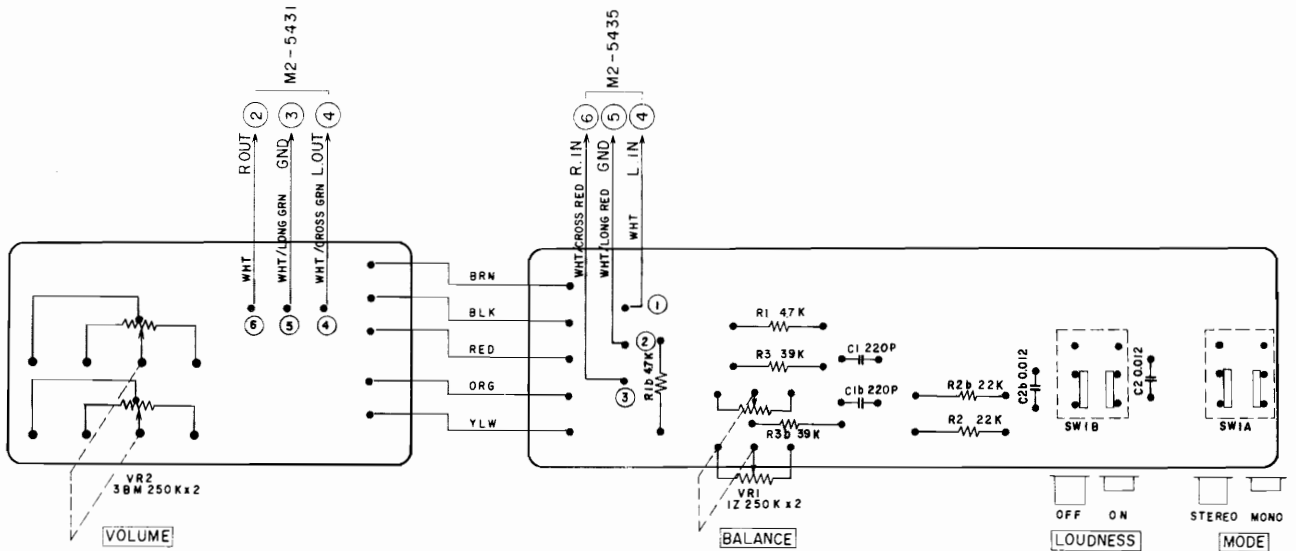

5) TAPE P.C BOARD M2-5435

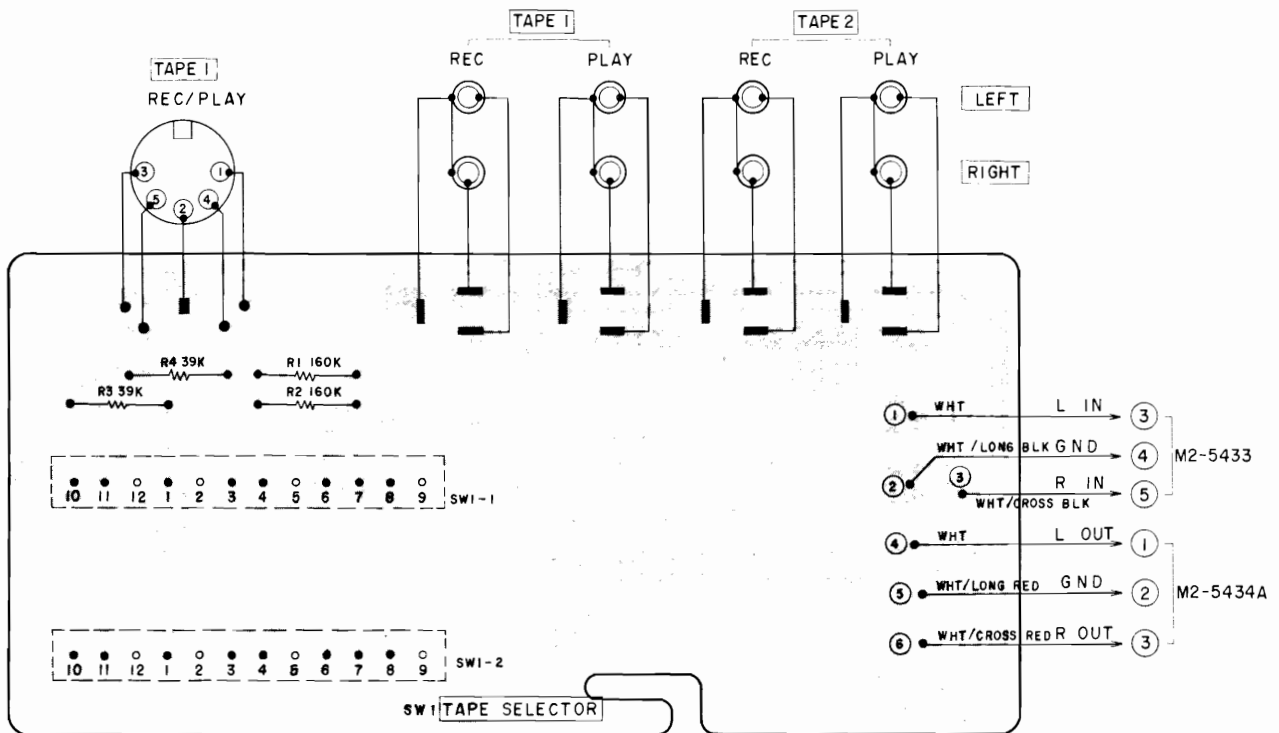

MEMO

---

MEMO

---

MEMO

---

MEMO

---



---

SECTION 2

**PARTS LIST**

TABLE OF CONTENTS

1. RECOMMENDED SPARE PARTS LIST .....	19
2. TONE CONTROL P.C BOARD (M2-5431) BLOCK .....	20
3. MAIN AMP P.C BOARD (M2-5432A) BLOCK .....	20
4. TEMP. COMPENSATION P.C BOARD (M2-5432B)/(M2-5432C) BLOCK .....	20
5. LED P.C BOARD (M2-5433A) BLOCK .....	21
6. EQ. P.C BOARD (M2-5433) BLOCK .....	21
7. VOL P.C BOARD (M2-5434A)/(M2-5434B) BLOCK .....	21
8. TAPE P.C BOARD (M2-5435) BLOCK .....	21
9. ASSEMBLY BLOCK .....	22
10. FINAL ASSEMBLY BLOCK .....	24
11. LIST OF INTERCHANGEABLE SEMICONDUCTORS .....	25
INDEX .....	26

Resistor and Capacitor which is not listed in this parts list, please refer to COMMON LIST FOR SERVICE PARTS.

## HOW TO USE THIS PARTS LIST

1. This parts list is compiled by various individual blocks based on assembly process.
2. When ordering parts, please describe parts number, serial number, and model number in detail.
3. How to read List

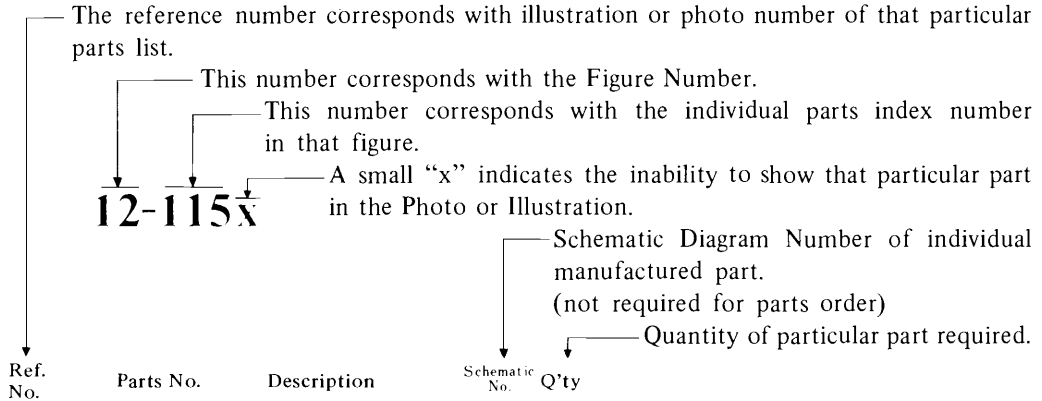

### FLYWHEEL BLOCK #13

12-115x	800425	Flywheel Block Assy. Comp.	RDG #13	1
12-116	244506	Flywheel Only	RD-233	1
12-117x	244754	Felt, Flywheel	RD-275	1
12-118	251324	Main Metal Case	RD-236	1
12-119	253080	Main Metal	RD-237	1

4. The symbol numbers shown on the P.C. Board list can be matched with the Composite Views of Components of the Schematic Diagram or Service Manual.
5. Please utilize separate "Common List for Service Parts" for Resistor Parts orders.
6. The shape of the parts and parts name, etc. can be confirmed by comparing them with the parts shown on the Electrical Parts Table of P.C. Board.
7. Both the kind of part and installation position can be determined by the Parts Number. To determine where a parts number is listed, utilize Parts Index at end of Parts List.  
It is necessary first of all to find the Parts Number. This can be accomplished by using the Reference Number listed at right of parts number in the Parts Index. (meaning of ref. no. outlined in Item 3 above).
8. Utilize separate "Price List for Parts" to determine unit price. The most simple method of finding parts Price is to utilize the reference number.

- CAUTION:**
1. When placing an order for parts, be sure to list the parts no. model no., and description. There are instances in which if any of this information is omitted, parts cannot be shipped or the wrong parts will be delivered.
  2. Please be careful not to make a mistake in the parts no. If the parts no. is in error, a part different from the one ordered may be delivered.

## 1. RECOMMENDED SPARE PARTS LIST

Because, if the parts listed below are on hand, almost any repair can be accomplished, we suggest that you stock these Recommended Spare Parts Items.

Parts No.	Description	Note
BA235721	Tone Control P.C Board Comp. M2-5431	
BA235732	Vol. P.C Board Comp. M2-5434A	
BA235743	Vol. P.C Board Comp. M2-5434B	
BA235888	LED P.C Board Comp. M2-5433A	
BA235866	EQ P.C Board Comp. M2-5433	
BA235877	Tape P.C Board Comp. M2-5435	
BA235765	Main Amp P.C Board Comp. M2-5432A	(U/T, CSA)
BA270415	Main Amp P.C Board Comp. M2-5432A	(CEE)
BA235798	Temp. Compensation P.C Board Comp. M2-5432B	
BA235800	Temp. Compensation P.C Board Comp. M2-5432C	
BC241751	Cabinet M2-5426	
BD235710	Front Panel Block Comp. AM-2400	
BT240390	Power Trans. AM-2400T-1	T901 (U/T)
BT245597	Power Trans. AM-2400T-3	T901 (CEE)
BT245575	Power Trans. AM-2400T-2	T901 (CSA)
EC240401	Elect./C. (Lug Type) 680 $\mu$ F 50WV	C902, C903
ED656357	LED SEL105R	
ED656278	Diode 1S2472HC	
ED245417	Diode GP20G	
ED240377	Diode RD36E (C)	
ED245430	Diode GP08D	
EJ624486	Power TR. Socket A	
EJ243641	6P Pin Jack	J1 (M2-5433)
EJ246216	8P Pin Jack	J1 (M2-5435)
EJ698051	Pin Jack	J2 (M2-5435)
EJ240581	4P Push Terminal	Speaker Terminal
EP245305	Relay MS4U 24V DC	RL1 (M2-5432A)
ES224436	Push SW. JP01	SW903
ES242343	Push SW. JP17	SW903 (CEE)
ES239218	Push SW. UP01 (TV-4)	SW903 (CSA)
ES240524	Rotary SW. SR321N 1-2-4 30KC	SW902
ES242245	Push SW. 3FT-0001FF4920	SW1 (M2-5431)
ES242256	Push SW. 3FT-0002FF4920	SW2 (M2-5431)
ES650171	Push SW. 2FT-0001FF4920	SW1 (M2-5434A)
ES243652	Rotary SW. SR26N 1-2-3	SW1 (M2-5433)
ES245733	Rotary SW. SR26N 1-2-5 20KC	SW1 (M2-5435)
ET204221	Transistor 2SA640-1 (E) (F) (G) (H)	
ET621235	Transistor 2SC536 (E) (F) (G)	
ET240660	Transistor 2SB560 (E) (F) RED	
ET649001	Transistor 2SD428 (O) (R)	
ET649012	Transistor 2SB558 (O) (R)	
ET240636	Transistor 2SC1940 (K) (L) (M)	
ET208012	Transistor 2SD571 (K) (L)	
EV242267	Single axial 2 throw Vol. V16L4G3N 50k $\times$ 2	VR1, VR2 (M2-5431)
EV224954	Single axial 2 throw Vol. V16L4G31Z 250k $\times$ 2	VR1 (M2-5434A)
EV224943	Single axial 2 throw Vol. V24L5G3BM 250k $\times$ 2	VR2 (M2-5434B)
EV484863	Semi-fixed/Vol. V10K8-2	VR1, VR2 (M2-5432A)
SB233717	Push Button (SQUARE) M2-5429	
SK224886	Power Knob M2-5021	
SK646817	Single Knob AA-5250	
SK240063	Selector Knob M2-5428	
SK241648	Volume Knob 1 M2-5427	
EZ624734	Mylar Sheet AC-201	

## 2. TONE CONTROL P.C BOARD

### (M2-5431) BLOCK

Symbol No.	Parts No.	Description	Schematic No.	Q'ty
2-1	BA235721	Tone Control P.C Board Comp. (M2-5431)		1
2-TR1,2	ET459810	Transistor 2SC1222(E)(F)	45-1-110	4
2-VR1	EV242267	Single axial 2 throw Vol. V16L4G3N 50kx2	36-22-19	2
2-SW1	ES242245	Push SW. 3FT-0001FF4920	25-5-230 25-5-231	1
2-SW2	ES242256	Push SW. 3FT-0002FF4920		1
2-2	ZS417216	Screw, pan head 3x4		4
2-3	ZS325495	Tapping Screw #2 3x6 (BR)		1
2-4	ZW273802	Toothed Lock Washer		1
2-C7	EC243393	Solid Aluminum/C. (Vert. Type) 0.22μF(K) 10WV	24-19-2	2
2-C8	EC243371	Solid Aluminum/C. (Vert. Type) 0.15μF(K) 10WV	24-19-2	2
2-C15	EC243371	Solid Aluminum/C. (Vert. Type) 0.15μF(K) 10WV	24-19-2	2

## 3. MAIN AMP P.C BOARD

### (M2-5432A) BLOCK

Symbol No.	Parts No.	Description	Schematic No.	Q'ty
3-1	BA235765	Main Amp P.C Board Comp. (M2-5432A)		1
3-2	BA270415	Main Amp P.C Board Comp. (M2-5432A) (CEE)		1
3-TR1,2	ET204221	Transistor 2SA640-1 (E)(F)(G)(H)	45-1-168	4
3-TR3	ET240671	Transistor 2SD438 (E)(F) RED	45-1-252	2
3-TR6	ET240671	Transistor 2SD438 (E)(F) RED	45-1-252	2
3-TR7	ET240660	Transistor 2SB560 (E)(F) RED	45-1-251	2
3-TR10,11	ET240636	Transistor 2SC1940 (K)(L)(M)	45-1-241	2
3-TR12	ET557965	Transistor 2SA733 (Q)(R)	45-1-124	1
3-TR13to15	ET520841	Transistor 2SC711 (E)(F)(G)	45-1-67	3
3-TR16	ET666404	Transistor 2SD571 (K)(L)	45-1-218	1
3-TR17	ET240660	Transistor 2SB560 (E)(F) RED	45-1-251	1
3-TR18	ET452531	Transistor 2SD313 (E)(F)	45-1-105	1
3-D2to8	ED214457	Silicon Diode 1S2472	45-3-41	7
3-D13	ED245430	Silicon Diode GP08D	45-2-68	1
3-D14	ED240377	Zener Diode RD36E(C)	45-6-72	1
3-D15	ED245430	Silicon Diode GP08D	45-2-68	1
3-D16to19	ED245417	Silicon Diode GP20G	45-2-70	4
3-VR1	EV484863	Semi-fixed/Vol. V10K8-4-2 1kB	36-10-250	2
3-L1,2	EO650823	Phase Equalizer Coil 2.2μH(K)	23-1-239	2
3-R19,20	ER622978	Metal Plate/R. MPC71F1 5W 0.47ohm(K)	35-16-48	4
3-R46	ER389687	Metal Oxide Film/R. 1W 220ohms(K)	35-15-10	1
3-R47	ER245531	Metal Oxide Film/R. 2W 1.5k(K)	35-15-8	1
3-R52,53	ER389687	Metal Oxide Film/R. 1W 220ohms(K)	35-15-10	2
3-C2	EC538244	Solid Aluminum/C. (Vert. Type) 0.47μF(M) 10WV	24-19-2	2
3-C21	EC662128	Solid Aluminum/C. (Vert. Type) 2.2μF(M) 25WV	24-19-2	1
3-3	EZ223132	Heat-sink Plate	T2-5022	1

## 4. TEMP. COMPENSATION P.C BOARD

### (M2-5432B), (M2-5432C) BLOCK

Symbol No.	Parts No.	Description	Schematic No.	Q'ty
4-1	BA235798	Temp. Compensation P.C Board Comp. B (M2-5432B)		1
4-2	BA235800	Temp. Compensation P.C Board Comp. C (M2-5432C) (AM-2400/2600/2800)		1
4-TR5	ET635218	Transistor 2SC945L(K)(P)(Q)(R)	45-1-85	1

When ordering parts, Please describe Parts Number, Description, and Model Number in detail.

---

## 5. LED P.C BOARD (M2-5433A) BLOCK

Symbol No.	Parts No.	Description	Schematic No.	Q'ty
5-1	EA241828	LED P.C Board (M2-5433A)		1
5-D1	ED656357	LED 105R	45 15-11	1

## 6. EQ. P.C BOARD (M2-5433) BLOCK

Symbol No.	Parts No.	Description	Schematic No.	Q'ty
6-1	BA235866	EQ. P.C Board Comp. (M2-5433)		1
6-TR1,2	ET459810	Transistor 2SC1222(E)(F)	45-1-110	4
6-SW1	ES243652	Rotary SW. SR26N1-2-3 20 KC	25 6 96	1
6-J1	EJ243641	6P Pin Jack	31 1 189	1

## 7. VOL P.C BOARD A(M2-5434A) BLOCK VOL P.C BOARD B(M2-5434B) BLOCK

Symbol No.	Parts No.	Description	Schematic No.	Q'ty
7-1	BA235732	Vol P.C Board A Comp. (M2-5434A)		1
7-2	BA235743	Vol P.C Board B Comp. (M2-5434B)		1
7-VR1	EV224954	Single axial 2 throw Vol. V16L4G 31Z 250kx2(A)	36-22-17	1
7-VR2	EV224943	Single axial 2 throw Vol. V24L5G 3BM 250kx2(B)	36-1-48	1
7-SW1	ES650171	Push SW. 2F-0005FF3220(A)	25 5-184	1

## 8. TAPE P.C BOARD (M2-5435) BLOCK

Symbol No.	Parts No.	Description	Schematic No.	Q'ty
8-1	BA235877	Tape P.C Board Comp. (M2-5435)		1
8-J1	EJ246216	8P Pin Jack	31 1-188	1
8-J2	EJ698015	Din Jack	31-1-158	1
8-SW1	ES245733	Rotary SW. SR26N1-2-5 20 KC	25 6-98	1

---

9. PHOTO OF ASSEMBLY BLOCK

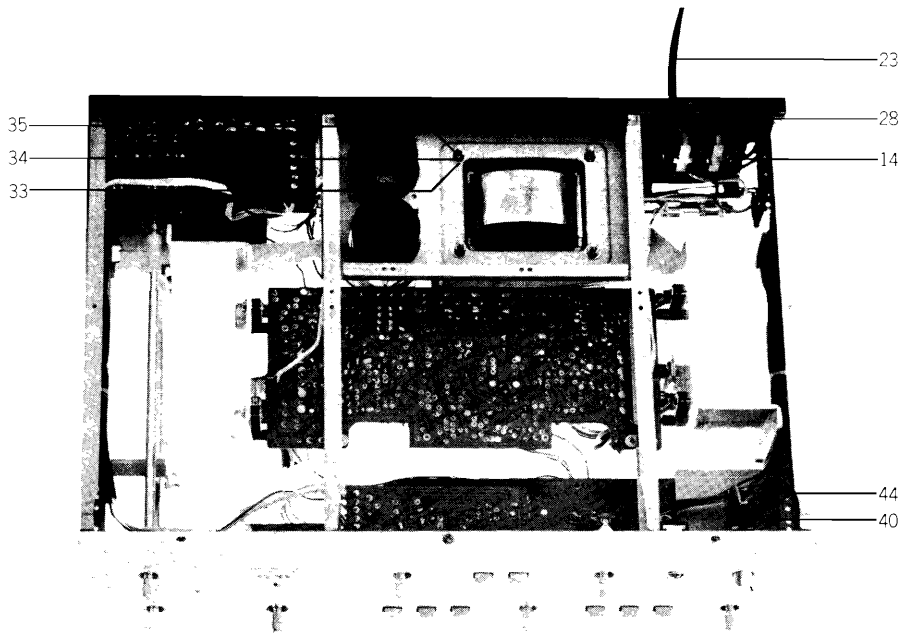
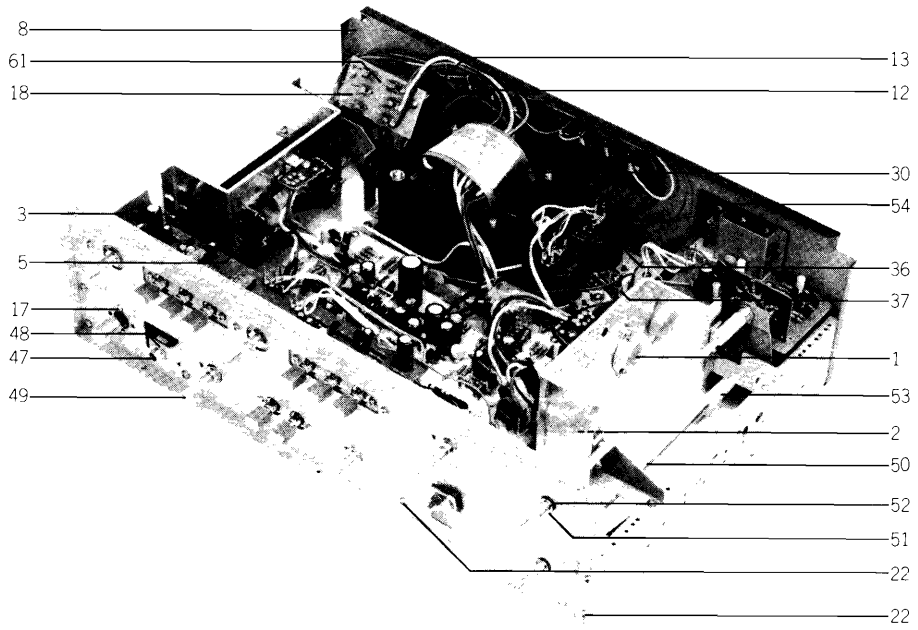

## 9) ASSEMBLY BLOCK

Ref. No.	Parts No.	Description	Schematic No.	Q'ty	Ref. No.	Parts No.	Description	Schematic No.	Q'ty
<b>HEAT-SINK BLOCK</b>									
9-1	ET649001	Transistor 2SD428(O)(Y)	45 1 219	2	9-52	ZW322110	Washer (Nylon) D6.1x10.3x1.0t		2
9-2	ET649012	Transistor 2SB558(O)(Y)	45 1 220	2	9-53	TA646773	Joint	AA 5240	2
9-3	EJ624486	Power Tr. Socket	31 1 97	4	9-54	ZW698308	Nylon Rivet (FNPR) 3x5.5 Black	2 7 54	5
9-4x	EZ624734	Mylar Sheet AC-201	45 16 18	4	9-55x	ZS447840	Tapping Screw #2 3x8(BR)		3
9-5	ZS593842	Screw, pan head 3x15 w/washer		8	9-56x	ZW330412	Adjust. Washer (U) D4x13x0.13t		2
9-6x	ZS447840	Tapping Screw #2 3x8(BR) (Tr. Mt. Plate)		2	9-57x	ZW330423	Adjust. Washer (U) D4x13x0.25t		2
9-7x	ZS447840	Tapping Screw #2 3x8(BR) (Heat-sink Mt. Plate)		8	9-58x	ZW330434	Adjust. Washer (U) D4x13x0.5t		2
<b>REAR PANEL BLOCK</b>									
9-8	SP244743	Rear Panel 1	M2 5420	1	9-59x	ZW330445	Adjust. Washer (U) D4x13x0.8t		2
9-9x	SP241222	Rear Panel 3 (CEE,VDE)	M2 5421	1	9-60x	ZW330456	Adjust. Washer (U) D4x13x1t		2
9-10x	SP241233	Rear Panel 2 (CSA)	M2 5420	1	9-61	EF563703	Fuse 2A 250V	39 1 50	1
9-11x	SP241211	Rear Panel 4 (BEAB)	M2 5421	1	9-62x	EF601942	Fuse (SEMKO T TYPE) 630 MAT (CEE,VDE,BEAB)	39 1 53	1
9-12	EJ240581	4P Push Terminal	32 1 72	2	9-63x	EF690996	Fuse (SEMKO T TYPE) 4AT (CEE,BEAB,VDE)	39 1 53	2
9-13	ZS522865	Tapping Screw #2 3x12(BR)		4	9-64x	EF277424	Fuse ST-4 0.8A (CSA,AAL)	39 1 28	1
9-14	EJ240535	3-throw AC Outlet	31 1 173	1	9-65x	EF378595	Fuse ST-2 4A (CSA,AAL)	39 1 63	1
9-15x	SK652397	Knob 0512-2	34 1 4	1	9-66x	ZW273881	Earth Lug (BEAB)		1
9-16x	ZW651082	Washer (SPC) D3.2x10x1t		1	9-67x	ZW273892	Toothed Lock Washer(BEAB)		1
9-17	ZS608477	Screw, pan head 3x4		2	9-68x	ZS417150	Screw, pan head 4x6 (BEAB)		1
9-18	EJ214975	3P Fuse Holder (Large) B (Luppling Type)	40 1 104	1	9-69x	ZW413188	Nut M4, #1 (BEAB)		1
9-19x	EJ246835	Fuse Holder, w/sticker AM-4S (CEE,VDE)	40 1 132	1					
9-20x	EJ244765	Fuse Holder, w/sticker AM-4L (CSA)	40 1 131	1					
9-21x	EJ246925	Fuse Holder, w/sticker AM-5S (BEAB)	40 1 133	1					
9-22	ZS325495	Tapping Screw #2 3x6(BR)		33					
9-23	EW540123	AC Cord (CUL) 2.5M	26 3 20	1					
9-24x	EW516600	AC Cord (CEE) VM-0065	26 3 28	1					
9-25x	EW516475	AC Cord (CSA) 2.5M	26 3 20	1					
9-26x	EW604585	AC Cord (BSI)	26 3 37	1					
9-27x	EW604618	AC Cord (EC) VM-0064	26 3 34	1					
9-28	EZ631945	Strain Relief SR-4N-4	2 7 49	1					
9-29x	EZ246936	Strain Relief SR-6W-1(BEAB)	2 7 8	1					
<b>ASSEMBLY BLOCK</b>									
9-30	BT240390	Power Trans. AM-2400T-1	38 4 437	1					
9-31x	BT245597	Power Trans. AM-2400T-3 (CEE,BEAB,VDE)	38 4 439	1					
9-32x	BT245575	Power Trans. AM-2400T-2 (CSA,AAL)	38 4 438	1					
9-33	ZW237857	Washer D4.1x10x1t		4					
9-34	ZW273914	Spring Washer		4					
9-35	ZW413188	Nut M4, #1		4					
9-36	EC240401	Elect./C. (Lug Type) 6800µF 50WV	24 10 113	2					
9-37	EJ551035	Wrapping Terminal, 4P T-5251	32 1 36	1					
9-38x	EJ539447	Earth Terminal 2P T4460	32 1 32	1					
9-39x	ZS447761	Tapping Screw #2 3x6(BR) (Black)		7					
9-40	ES224436	Push SW. JP01	25 5 221	1					
9-41x	ES242346	Push SW. JPI7 (CEE,BEAB,VDE)		1					
9-42x	ES239218	Push SW. JP01 (TV-4) (CSA,AAL)	25 5 222	1					
9-43x	ZS417216	Screw, pan head 3x4		10					
9-44	EC204671	Ceramic/C. DD31-6 0.01µF(P) 500WV	24 5 66	14					
9-45x	EC565896	Ceramic/C. DP6600YM 0.01µF(P) 1.4kWV (CSA,AAL)	24 5 58	1					
9-46x	EC286198	Ceramic/C. AL-10 0.01µF(Z) 125WV (CSA,AAL) *Change from: 11134-0001	24 5 69	1					
9-47	EJ655716	Head Phone Jack 3PMJ1E	31 2 67	1					
9-48	ZW554624	E Jack Nut	7 1 56	1					
9-49	ES240524	Rotary SW. SR321N1-2-4 30KC	25 7 47	1					
9-50	MS241571	Relay Shaft A		2					
9-51	ZW270123	'E' Ring 4M		4					

When ordering parts, Please describe Parts Number, Description, and Model Number in detail.

## 10. PHOTO OF FINAL ASSEMBLY BLOCK

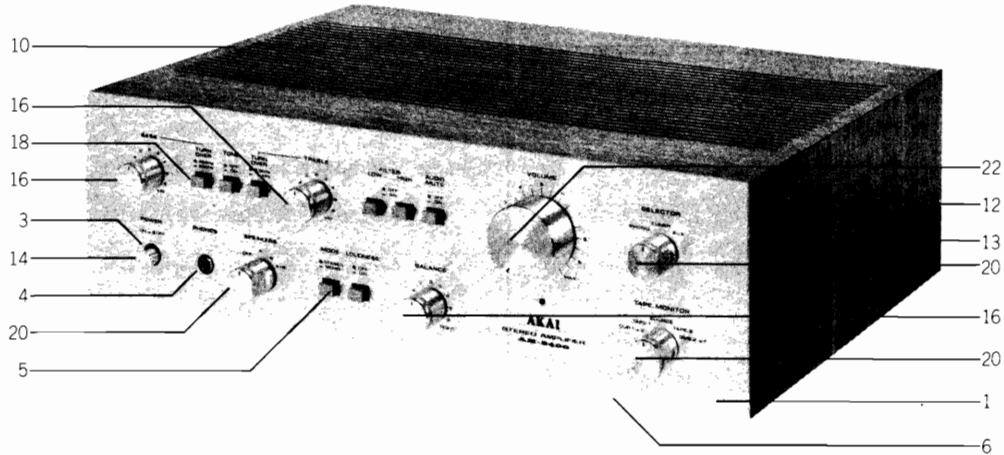

### 10) FINAL ASSEMBLY BLOCK

Ref. No.	Parts No.	Description	Schematic No.	Q'ty
<b>FRONT PANEL BLOCK</b>				
10-1	BD235710	Front Panel Block Comp.		1
10-2	BD281081	Front Panel Block Comp. (BL)		1
10-3	MZ224627	Push Button Bush A	M2-5004	1
10-4	ZW526577	Collar B, Jack	MC-5006	1
10-5	SE233987	Escutcheon	M2-5430	8
<b>ASSEMBLY BLOCK</b>				
10-6	SD233684	Bottom Plate A	M2-5425	1
10-7x	ZS447840	Tapping Screw #2 3x8(BR)		9
10-8x	SZ645243	Circular Foot A CA	CA-6014	4
10-9x	ZS565942	Tapping Screw #2 4x8(pan)		4
10-10	BC241751	Cabinet	M2-5426	1
10-11x	BC281496	Cabinet (BL)	M2-5426	1
10-12	ZW548010	Spot Facing Washer	MU-6028	4
10-13	ZS510344	Screw, binding head 4x12		4
10-14	SK224886	Power Knob AT-2200	M2-5021	1
10-15x	SK236970	Power Knob (BL)	MU-6320	1
10-16	SK646817	Single Knob	AA-5250	3
10-17x	SK281564	Single Knob (BL)	AA-5250	3
10-18	SB233717	Push Button (Square)	M2-5429	8
10-19x	SB288720	Push Button (Square) (BL)	M2-5429	8
10-20	SK240063	Selector Knob	M2-5428	3
10-21x	SK281597	Selector Knob (BL)	M2-5428	3
10-22	SK241648	Vol. Knob 1	M2-5427	1
10-23x	SK281507	Vol. Knob 1 (BL)	M2-5427	1

When ordering parts, Please describe Parts Number, Description, and Model Number in detail.



## 11. LIST OF INTERCHANGEABLE SEMICONDUCTORS

As far as service is concerned, in case the original parts cannot be obtained, the interchangeable parts listed below can be substituted.

Original Parts			Interchangeable Parts	
Description	Parts No.	Utilizing P.C Board	Description	Parts No.
2SC1222 (E) (F)	ET459810	M2-5431 M2-5433	2SC1124 (BL) (GR) 2SC1313 (G) (H)	ET622181 ET604124
2SA640-1 (E) (F) (G) (H)	ET204221	M2-5432A		
2SD438 (E) (F)	ET219857	M2-5432A	2SC1625 (O) (Y)	ET649067
2SC536 (E) (F) (G)	ET621235	M2-5432A		
2SB560 (E) (F) RED	ET240660	M2-5432A		
2SD428 (O) (R)	ET649001	M2-5432A		
2SB558 (O) (R)	ET649012	M2-5432A		
2SC1940 (K) (L) (M)	ET240636	M2-5432A		
2SA733 (Q) (R)	ET557965	M2-5432A	2SA564 (Q) (R)	ET538154
2SD571 (K) (L)	ET208012	M2-5432A		
2SD313 (E) (F)	ET452531	M2-5432A	2SD571 (L) (M)	ET655356
SEL105R	ED656357	M2-5433A		
1S2472HC	ED656278	M2-5432A		
GP08D	ED245430	M2-5432A	1N34A	ED417442
GP20G	ED245417	M2-5432A		
RD36E (C)	ED240377	M2-5432A		

# INDEX

Parts No.	Ref. No. & Symbol No.	Parts No.	Ref. No. & Symbol No.	Parts No.	Ref. No. & Symbol No.	Parts No.	Ref. No. & Symbol No.	Parts No.	Ref. No. & Symbol No.
BA235721	2-1	EV224954	7-VR1						
BA235732	7-1	EV242267	2-VR1						
BA235743	7-2	EV484863	3-VR1						
BA235765	3-1	EW516475	9-25x						
BA235798	4-1	EW516600	9-24x						
BA235800	4-2	EW540123	9-23						
BA235866	6-1	EW604585	9-26x						
BA235877	8-1	EW604618	9-27x						
BA270415	3-2	EZ223132	3-3						
BC241751	10-10	EZ246936	9-29x						
BC281496	10-11x	EZ624734	9-4x						
BD235710	10-1	EZ631945	9-28						
BD281081	10-2	MS241571	9-50						
BT240390	9-30	MZ224627	10-3						
BT245575	9-32x	SB233717	10-18						
BT245597	9-31x	SB288720	10-19x						
EA241828	5-1	SD233684	10-6						
EC204671	9-44	SF233987	10-5						
EC240401	9-36	SK224886	10-14						
EC243371	2-C8	SK236970	10-15x						
EC243371	2-C15	SK240063	10-20						
EC243393	2-C7	SK241648	10-22						
EC286198	9-46x	SK281507	10-23x						
EC538244	3-C2	SK281564	10-17x						
EC565896	9-45x	SK281597	10-21x						
EC662128	3-C21	SK646817	10-16						
ED214457	3-D2to8	SK652397	9-15x						
ED240377	3-D14	SP241211	9-11x						
ED245417	3-D16to19	SP241222	9-9x						
ED245430	3-D13	SP241233	9-10x						
ED245430	3-D15	SP244743	9-8						
ED656357	5-D1	SZ645243	10-8x						
EF277424	9-64x	TA646773	9-53						
EF378595	9-65x	ZS325495	2-3						
EF563703	9-61	ZS325495	9-22						
EF601942	9-62x	ZS417150	9-68x						
EF690996	9-63x	ZS417216	2-2						
EJ214975	9-18	ZS417216	9-43x						
EJ240535	9-14	ZS447761	9-39x						
EJ240581	9-12	ZS447840	9-6x						
EJ243641	6-J1	ZS447840	9-7x						
EJ244765	9-20x	ZS447840	9-55x						
EJ246216	8-J1	ZS447840	10-7x						
EJ246835	9-19x	ZS510344	10-13						
EJ246925	9-21x	ZS522865	9-13						
EJ539447	9-38x	ZS565942	10-9x						
EJ551035	9-37	ZS593842	9-5						
EJ624486	9-3	ZS608477	9-17						
EJ655716	9-47	ZW237857	9-33						
EJ698051	8-J2	ZW270123	9-51						
EO650823	3-L1,2	ZW273802	2-4						
ER245531	3-R47	ZW273881	9-66x						
ER389687	3-R46	ZW273892	9-67x						
ER389687	3-R52,53	ZW273914	9-34						
ER622978	3-R19,20	ZW322110	9-52						
ES224436	9-40	ZW330412	9-56x						
ES239218	9-42x	ZW330423	9-57x						
ES240524	9-49	ZW330434	9-58x						
ES242245	2-SW1	ZW330445	9-59x						
ES242256	2-SW2	ZW330456	9-60x						
ES242346	9-41x	ZW413188	9-35						
ES243652	6-SW1	ZW413188	9-69x						
ES245733	8-SW1	ZW526577	10-4						
ES650171	7-SW1	ZW548010	10-12						
ET204221	3-TR1,2	ZW554624	9-48						
ET240636	3-TR10,11	ZW651082	9-16x						
ET240660	3-TR7	ZW698308	9-54						
ET240660	3-TR17								
ET240671	3-TR3								
ET240671	3-TR6								
ET452531	3-TR18								
ET459810	2-TR1,2								
ET459810	6-TR1,2								
ET520841	3-TR13to15								
ET557965	3-TR12								
ET635218	4-TR5								
ET649001	9-1								
ET649012	9-2								
ET666404	3-TR16								
EV224943	7-VR2								

---

SECTION 3

**SCHEMATIC DIAGRAM**

1. AM-2400 NO. 1540658A SCHEMATIC DIAGRAM

---

AM-2400

Be 1st and 2nd EC

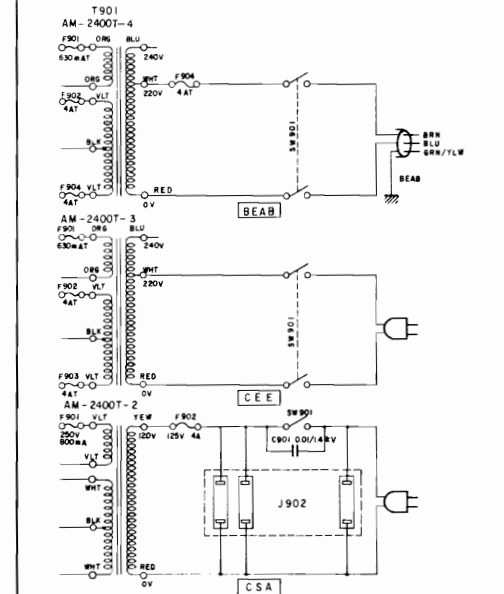
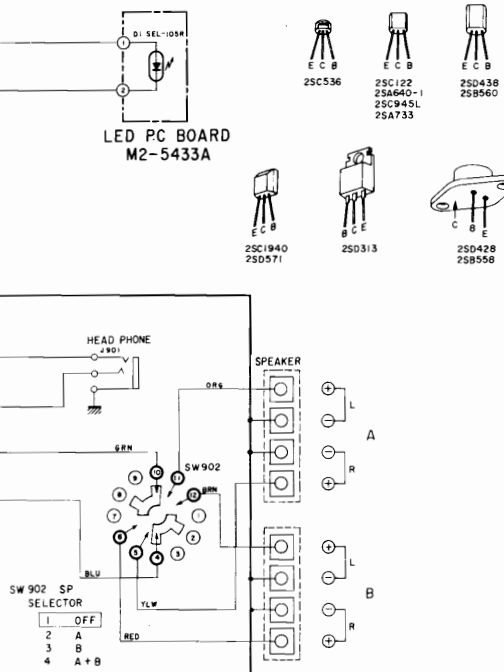
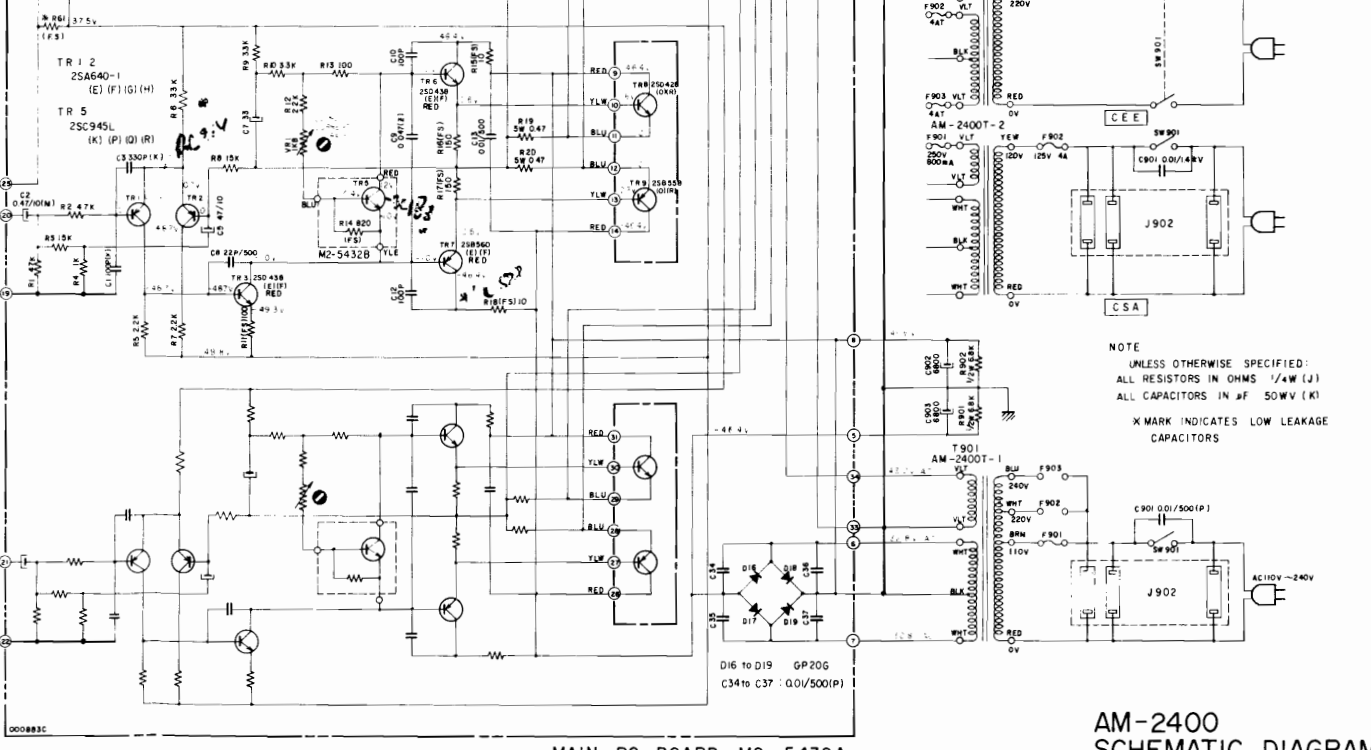
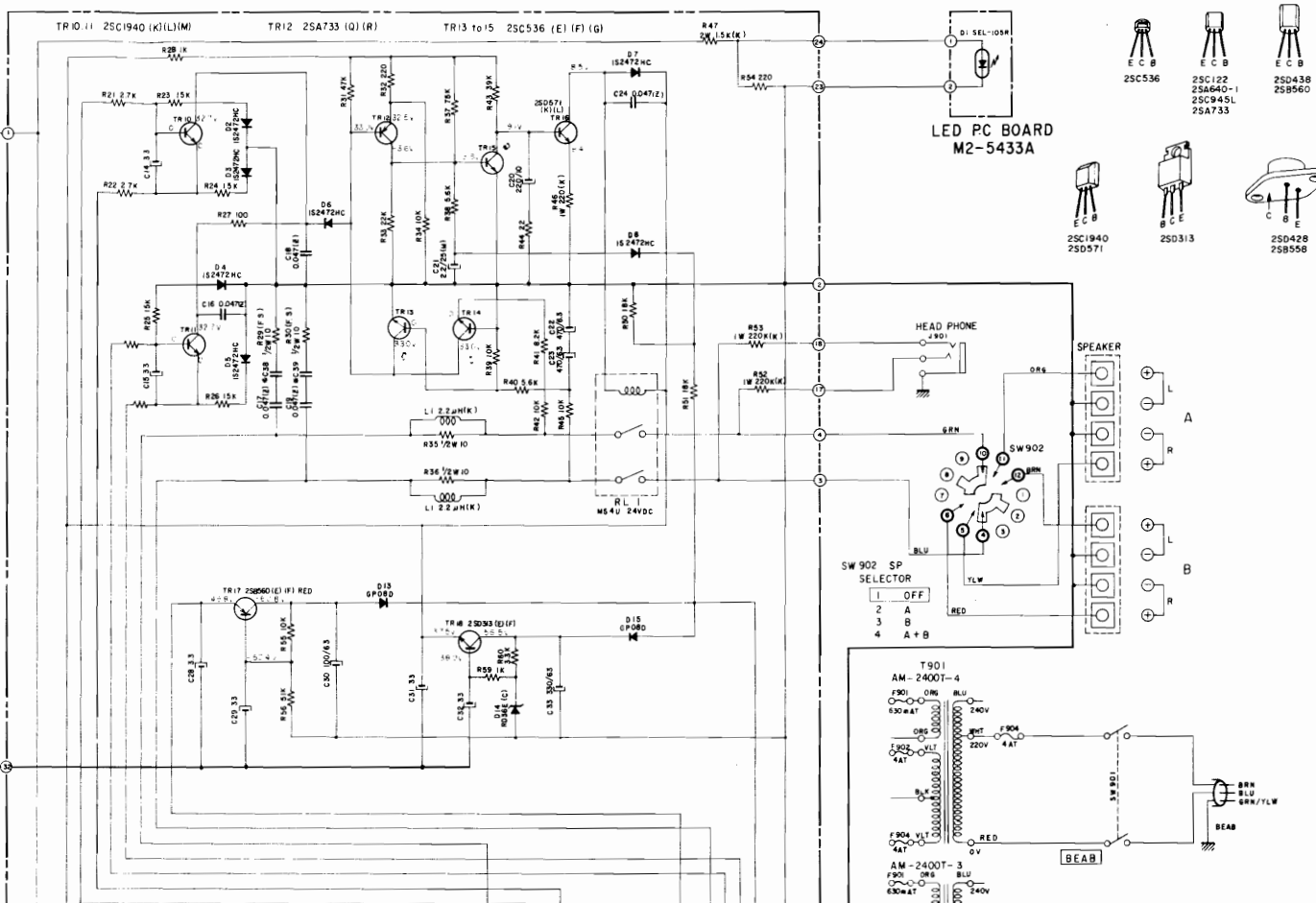
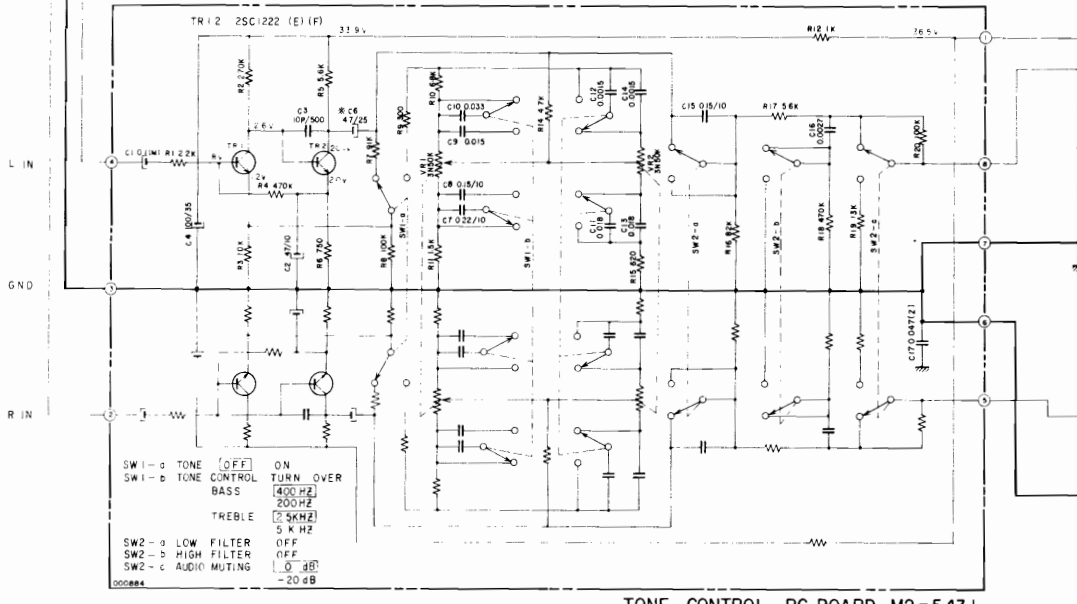
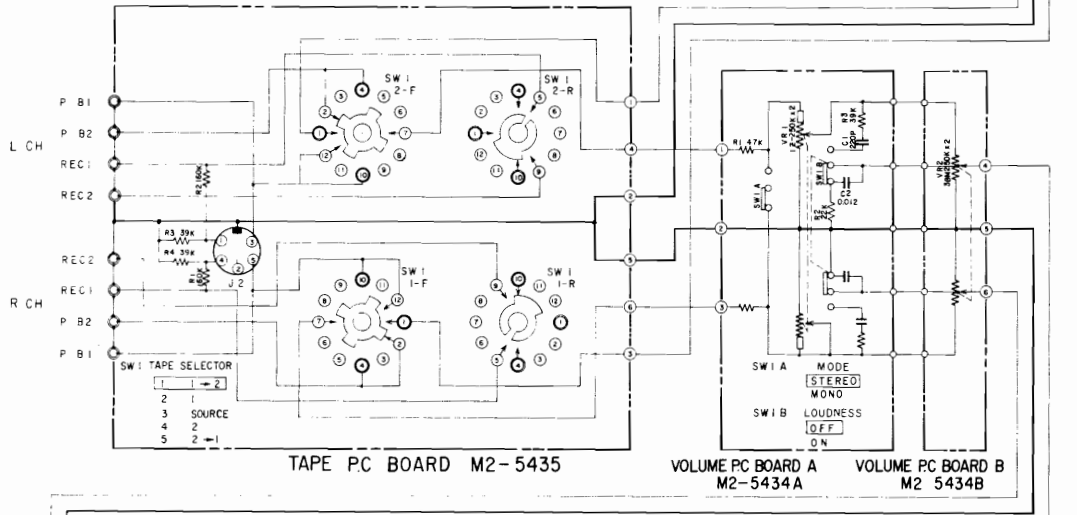
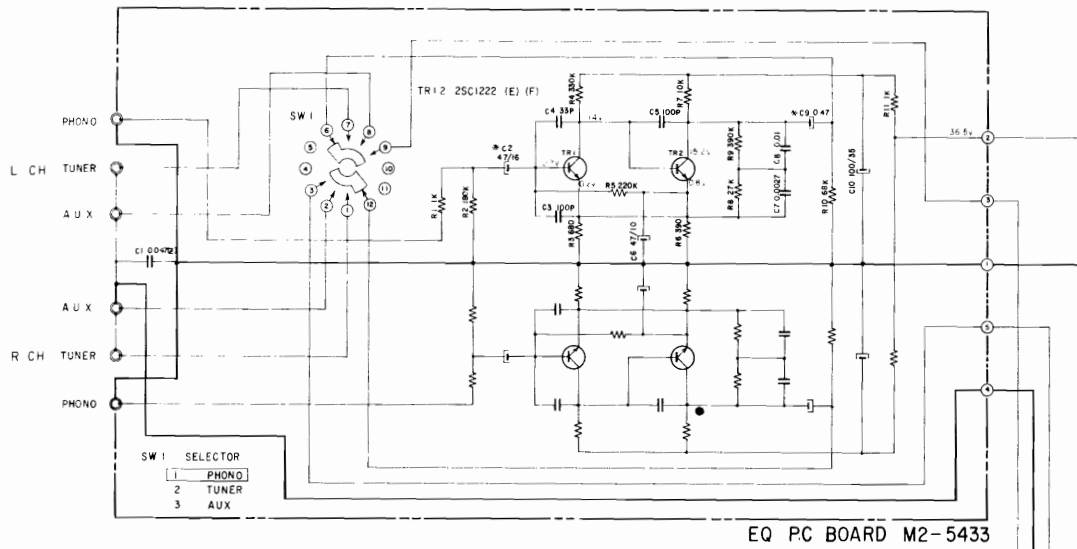

NOTE  
UNLESS OTHERWISE SPECIFIED:  
ALL RESISTORS IN OHMS 1/4W (J)  
ALL CAPACITORS IN μF 50WV (K)  
X MARK INDICATES LOW LEAKAGE CAPACITORS

AM-2400  
SCHEMATIC DIAGRAM  
NO. 1540658A

Audio continuity

