

Garrard Automatic Record Changers

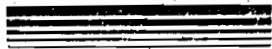

Models RC110 and RC111



Installation, Operation and Service Instructions

CONTENTS

	Page
DESCRIPTION	1
OPERATING INSTRUCTIONS ...	2
INSTALLATION	4
MAINTENANCE	4
SERVICE ADJUSTMENTS	6
SPARE PARTS LIST	11

The GARRARD Record Changers Models R.C.110 and R.C.111 are
made under the following patents:—

British	Switzerland	Canada	U.S.A.
632828	274287	470705	2507806
673030	290036		
687832	268211	Sweden	Prov. Pats.
607267	283111	137518	18080/53
673852			21070/53

The "Garrard" Models RC110 and RC111 Record Changers

DESCRIPTION. The "GARRARD" Model R.C. 110 has a one-piece diecast aluminium pick-up arm with the pick-up head integral with it while the Model R.C. 111 has a die cast aluminium pick-up arm to take the "GARRARD" MPM2 plug-in pick-up moulding which can be fitted with a range of pick-up cartridges. Reference in this booklet to the R.C. 110 also applies to the R.C. 111 except where stated.

"GARRARD" Record Changers are simple and reliable in operation. They are thoroughly tested before leaving our Works and will give a long period of satisfactory service.

Instructions for operating the Model R.C.110 are given in this manual—please follow these instructions carefully. In common with all mechanical devices, however, minor adjustments are sometimes necessary. The Service Instructions included have been com-

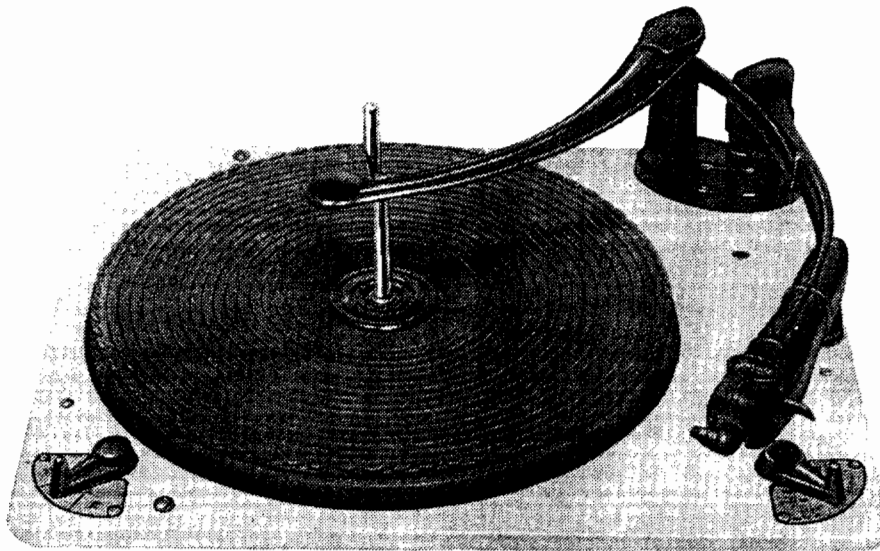

pleted to cover practically all the information necessary to ensure efficient operation.

If, after carefully perusing this manual you are still in doubt, our Technical Department will gladly assist you.

NOTE.

Always mention the Model Number, Schedule Number, and type of Pickup Head fitted when communicating with the company.

Address your inquiries to:—

The Garrard Engineering and Manufacturing
Company Ltd.,
Technical Service Dept.,
Newcastle Street,
Swindon, Wilts.

Telephone No.: Swindon 5381 (5 lines).

If you wish to make enquiries concerning the return of a Unit for repair, or to order Spare Parts, address your letter to:—

The Garrard Engineering and Manufacturing
Company Ltd.,
Service and Spares Dept.,
Okus Road,
Swindon, Wilts.

Telephone No.: Swindon 3405.

OPERATING INSTRUCTIONS

The "GARRARD" Model R.C.110 Record Changer will play automatically any number of records up to 10, the R.C.111 up to 8, of any one of the following types at each loading 10" or 12" at 78 r.p.m. 7", 10 or 12" at 33 $\frac{1}{3}$ r.p.m.—7" at 45 r.p.m. 7" 45 r.p.m. records may be played using the large record spindle type LRS2 (available as an optional extra) or centre hole clip in adaptors available at record stores.

TO OPERATE CHANGER PROCEED AS FOLLOWS:—

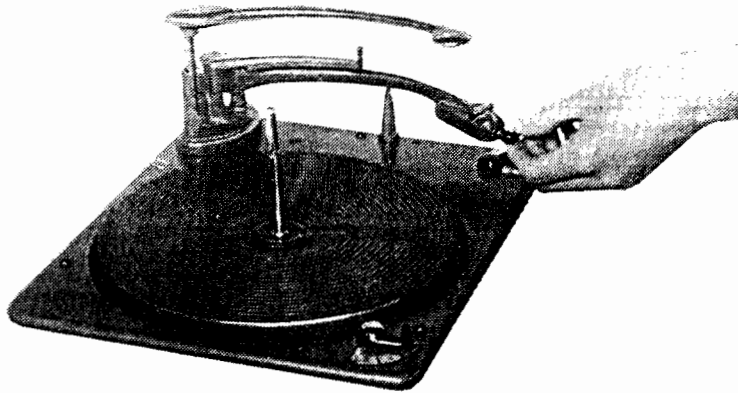

1. Set correct stylus for type of record to be played.

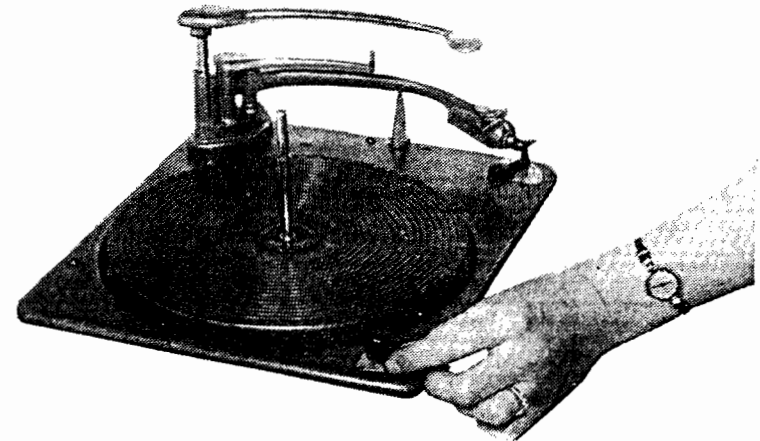

2. Move Speed Change Knob to desired speed.

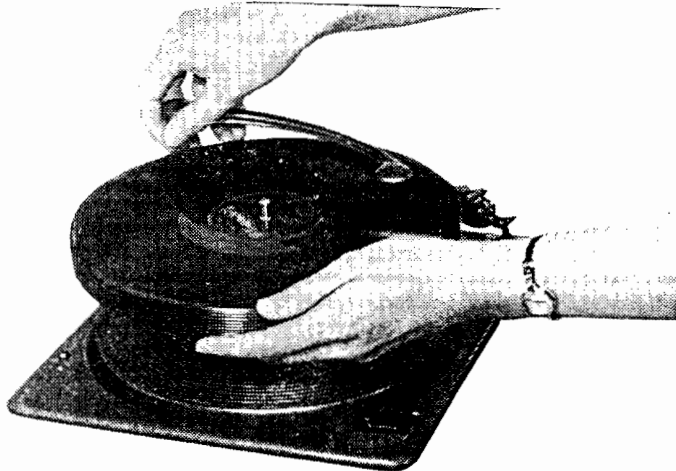

3. Place records on Record Spindle and move Overarm inward.



4. Switch on.

TO UNLOAD CHANGER:—



1. Lift Overarm and move to right hand side.



2. Lift records off Spindle.

REJECT. To reject a record move right hand knob to "Reject" position.

STOP. If it is desired to stop the changer before it does so automatically, move right hand knob to "Stop" position. If this is done while a record is playing that record will be rejected on switching on again. When lifting records off the record spindle do not grip them, hold them loosely.

PICKUP. To play 78 r.p.m. records the knob of the turnover pickup should show 78 or STD and for $33\frac{1}{3}$ or 45 r.p.m. records it should show 33/45 or LP.

Should the Record Changer be stopped with the pickup arm not on its rest the pickup should not be handled but the right hand knob should be moved to "Start" when the changer will operate and the pickup arm will lift and return to its rest.

The pickup arm will not move from its rest unless one or more records are on the record spindle. This is a safety device designed to prevent the pickup being damaged should the changer be switched on without being loaded with records.

RECORDS. To obtain the best results from your records preserve the surface by keeping them as dust free as possible, and it is recommended that microgroove records be cleaned with a clean soft damp cloth, also keep the turntable surface clean. Avoid touching the music lines, keep records away from heat and keep in container when not required for playing. Do not play chipped or cracked records as they will damage the sapphire stylus point and badly warped records will give trouble in dropping. Do not leave records on turntable when changer is not in use.

INSTALLATION

DIMENSIONS.

The Model R.C.110 Record Changer is $12\frac{2}{8}$ " long by $10\frac{3}{4}$ " back to front by $2\frac{2}{3}$ " below and $4\frac{1}{2}$ " above top of motor board. Clearance must be allowed for 12" records also at least $\frac{1}{8}$ " all round to allow unit to float freely on its suspension springs.

FITTING TO CABINET.

The motor board should be drilled and cut out as shown on template enclosed with each unit.

Having opened the carton remove the top liner and the changer will be seen cradled in the side liner which has finger slots in opposite sides. With the fingers in these slots lift out the liner complete with the changer. Remove all string and elastic bands. Connect a lead from the mains supply to the mains terminal block on rear of motor, Diagram 8. Also see that the links in the terminal block are set correctly for the voltage of the power supply. Diagram 4. Next connect a length of screened pickup lead to the tags on the pickup connecting strip as shown on Diagram 1. Also connect a lead from a good earth point to the earthing tag on motor Diagram 8.

Using the string loops, the changer can now be placed in position and fixed to the motor board by pressing the spring suspensions down through the holes provided in the cut-out. A small leaf spring is fitted immediately below the suspension spring and this flexes upwards as it passes through the hole in the motor board, after which it flattens out again and retains the unit in position. **It is essential to use the spring suspension assemblies on this model changer to prevent extraneous vibration from reaching the unit.**

Adjustment where necessary, to level the unit, is made by turning each suspension screw—clockwise to lower the unit and counter clockwise to raise it.

These spring suspensions, illustrated in Diagram 2, are designed for motor boards $\frac{1}{2}$ " thick or less and should it be found necessary to use a board thicker than $\frac{1}{2}$ ", the fixing holes should be recessed $1\frac{1}{4}$ " diameter from underneath, to bring the thickness of the board to $\frac{1}{2}$ " from the top.

TRANSIT SCREWS.

Two plated wood screws are supplied for use in clamping the changer to the motor board for transit purposes. The small bakelite washers should be fitted

under these screws to prevent marking the unit plate. **These screws must be removed before using the Record Changer.** The position of the transit screws are shown on Diagram 3.

MAINTENANCE

The motor and intermediate wheel bearings are of the oil retaining type and rarely need lubricating, when the need for oil is apparent hold the intermediate wheel out of the way and lubricate the top motor bearing with a fine grade of machine oil. Carefully remove all traces of surplus oil before running. The intermediate wheel rubber, motor pulley and inside of turntable rim must be kept free of oil.

To remove the turntable give the turntable mat centre a quarter turn in a clockwise direction and lift off the turntable mat. Next remove the lower retaining clip, Diagram 5. On no account remove retaining clip for main spindle. The turntable can now be removed by carefully lifting with equal pressure on diametrically opposite sides. Turntable should be replaced with the changer in the switched off position.

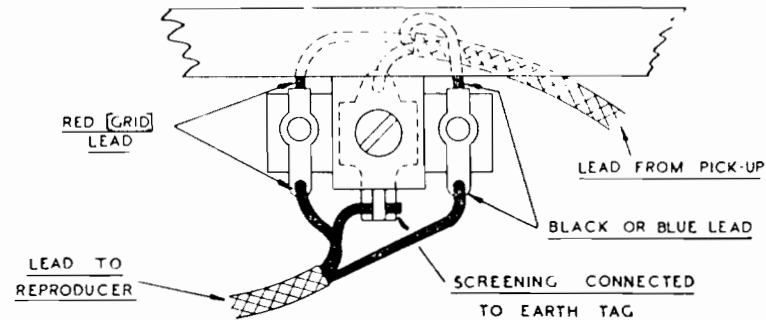

Diagram 1

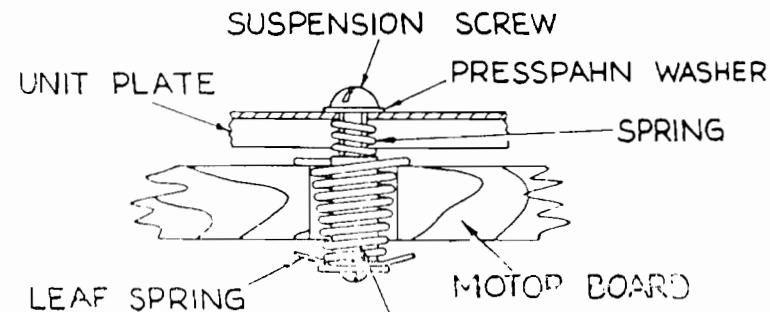
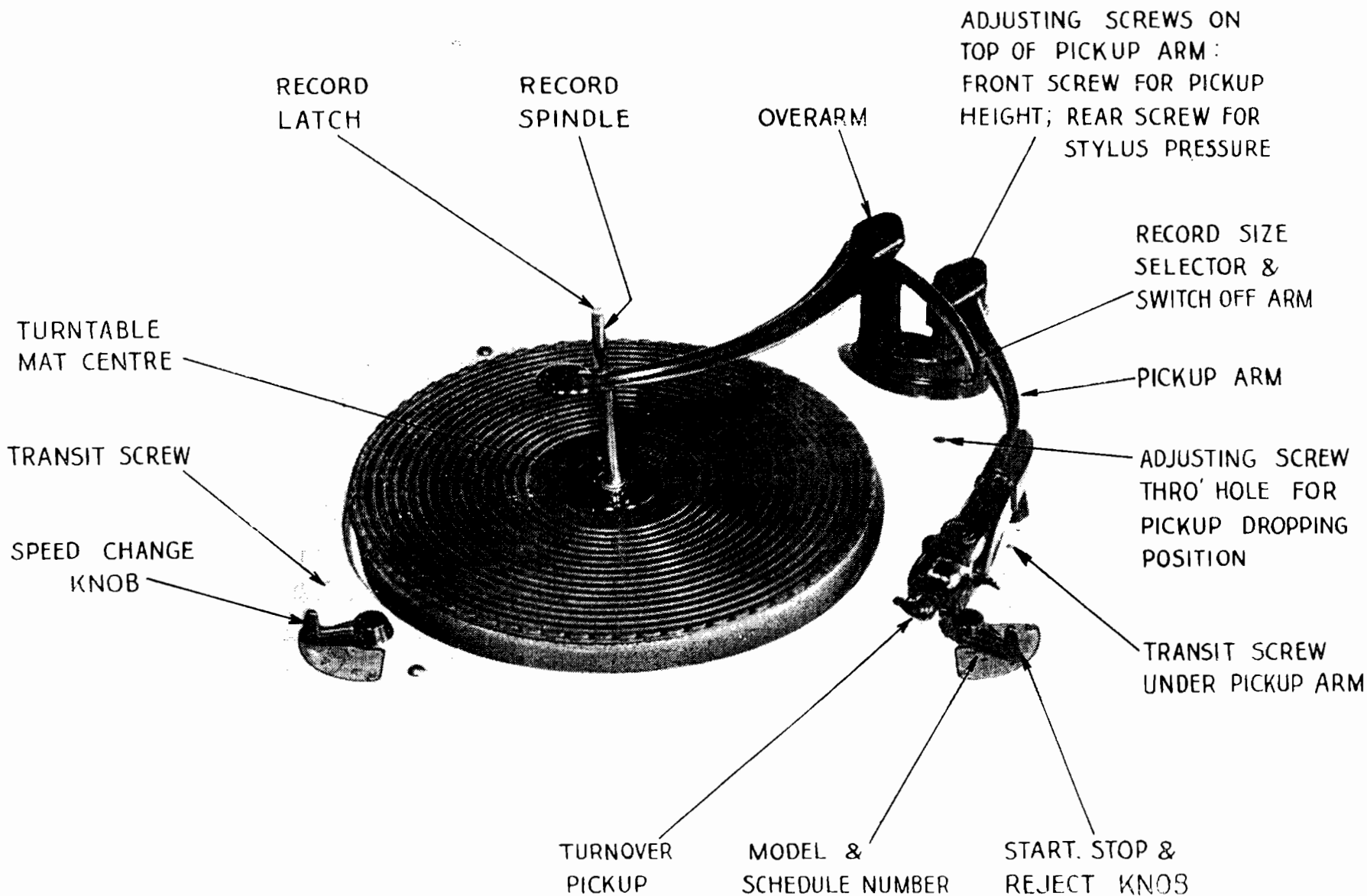

Diagram 2 SPRING SUSPENSION ASSEMBLY



Top View of R.C.110.

Diagram 3

SERVICE ADJUSTMENTS

These notes are included to help the owner of the Record Changer make any minor adjustments that may become necessary. When making any adjustments to the changer always place a 12" record on the turntable to protect the pickup stylus should it inadvertently land.

SPEED.

The Model R.C.110 motor is designed to give the desired turntable speed within close tolerances. Should the turntable run excessively fast or slow and the speed change knob is set correctly, examine the motor pulley to see if it is the correct one to suit the frequency of the mains supply.

To assist identification the motor pulley is colour finished as follows to distinguish the two types:—

Nickel	-	50 cycles
Brass	-	60 cycles

SPEED VARIATION.

Should the speed vary during playing remove the turntable as described on Page 4, and examine the motor pulley, intermediate wheel and inside of turntable rim for traces of oil and if necessary wipe thoroughly with a clean cloth. Also check that the motor pulley is in its correct position on the motor shaft, switch the changer on and see that the intermediate wheel runs in the centre of the appropriate step on the pulley and does not foul the side of the adjacent step, if necessary loosen the screw holding pulley to shaft and move pulley to its correct position.

MOTOR.

If motor fails to start when changer is switched on first check the power supply to see if current is reaching the motor terminals. If correct, switch off the mains supply and examine the terminal block and switch, see that the terminals and the links are tight and that the blades in the switch block are clean and making good contact when the switch is in "On" position, clean and adjust if necessary.

See that the motor shaft is free, if it is not, try lubricating with very thin oil and spinning the shaft, thick oil must not be used.

If motor momentarily starts then stops when switching on, check the "Switch Catch Lever," Diagram 8, it should engage with and hold the switch lever when switched on. If it does not hold in position, adjustment on the "Trip Link" is provided to correct this. Loosen the two screws "Trip Link Adjustment," Diagram 8 and increase or decrease the length of the trip link as required.

Connect both bars thus
for 200/250 volts A.C.

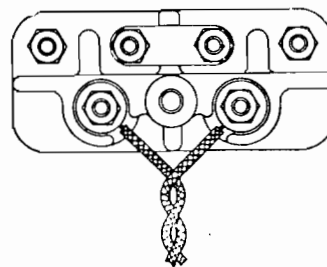

Connect bars thus for
100/130 volts A.C.

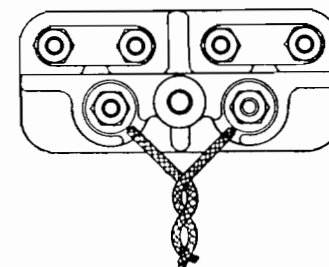

Terminal Block and Voltage Change over Link Connections.

Diagram 4

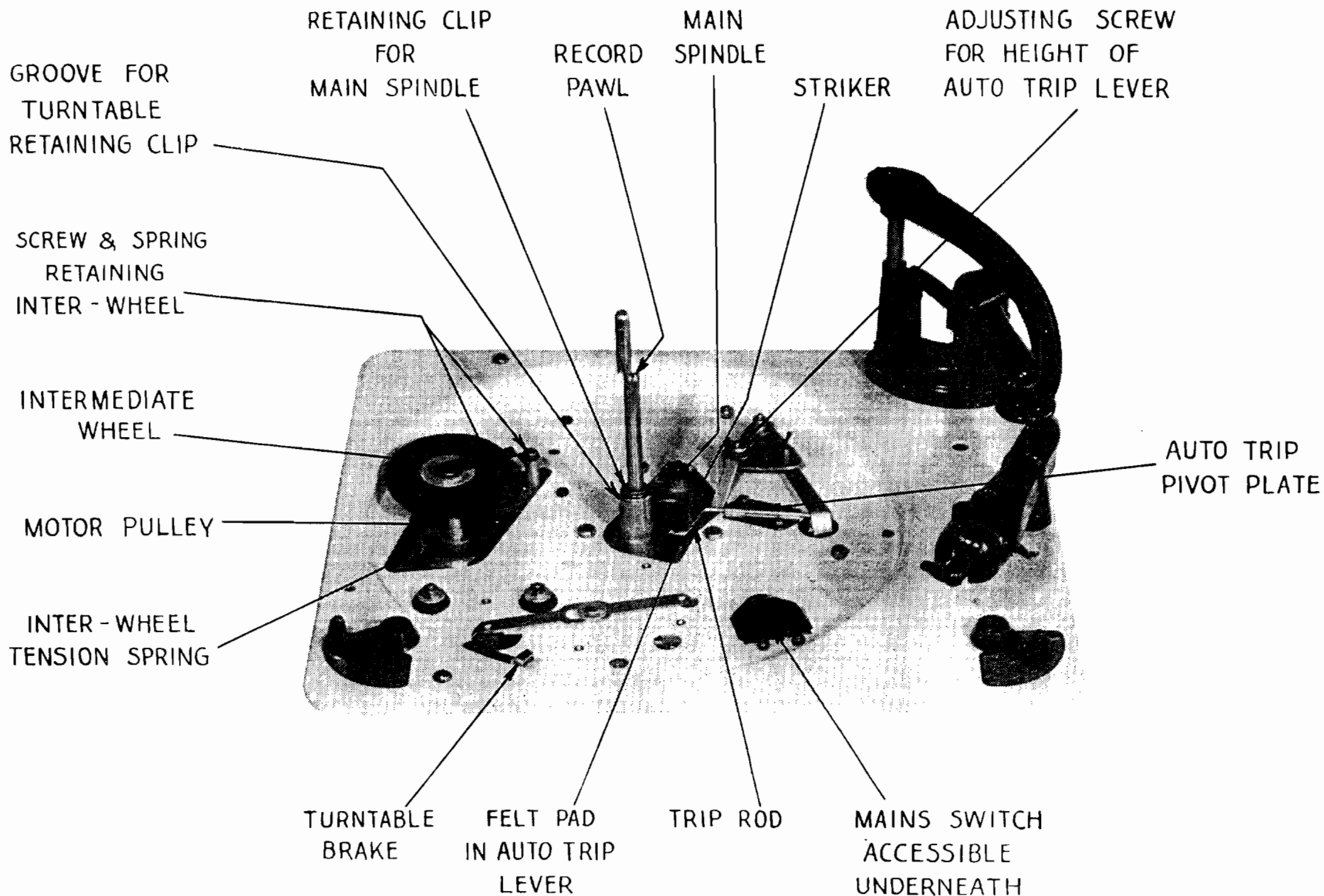

View with Turntable removed.

Diagram 5



Setting Pickup height

Diagram 6

Should the motor run too hot check that the voltage change over links in the mains terminal and change over block are set correctly to correspond to the voltage of the power supply, Diagram 4. If correct check the motor windings by inserting an A.C. ammeter in either motor lead, the current should not exceed 0.26 amp. on 100/130 volts or 0.13 amp. on 200/250 volts 50/60 cycles. If readings in excess of these figures are obtained the motor should be returned for examination.

PICKUP DROPPING POSITION.

The pickup arm dropping position is factory set for optimum accuracy, should however any minor adjustment be required to accommodate abnormal records rotate the screw accessible through the hole in top plate as shown in Diagram 3, this adjustment can only be made with the pickup arm on its rest.

PICKUP HEIGHT.

The distance the pickup lifts can be adjusted by turning the front screw at rear of pickup arm Diagrams 3 and 6, with a small screwdriver. Ten (8 for R.C.111) 12" 78 r.p.m. records should be placed on turntable and the pickup height adjusted so that as the pickup returns to the rest on completion of the top record the tip of the pickup stylus clears the record by $\frac{1}{8}$ ".

PICKUP STYLUS PRESSURE.

The stylus pressure for playing microgroove records must not exceed 10 grammes and it is strongly recommended that a check be made occasionally with a "GARRARD" Stylus Pressure Gauge. To adjust the stylus pressure turn the rear screw at rear of pickup arm Diagrams 3 and 7 with a small screwdriver, clockwise to reduce pressure and counterclockwise to increase it.

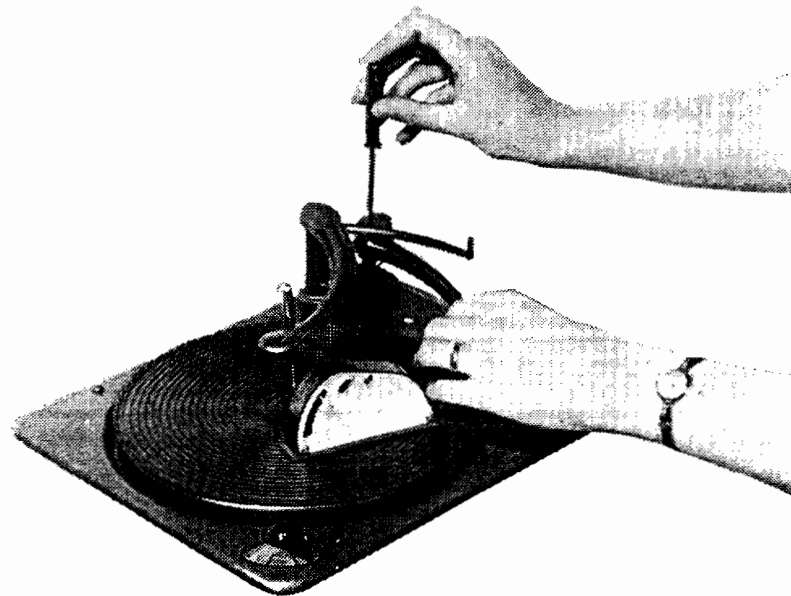

Adjusting Stylus Pressure

Diagram 7

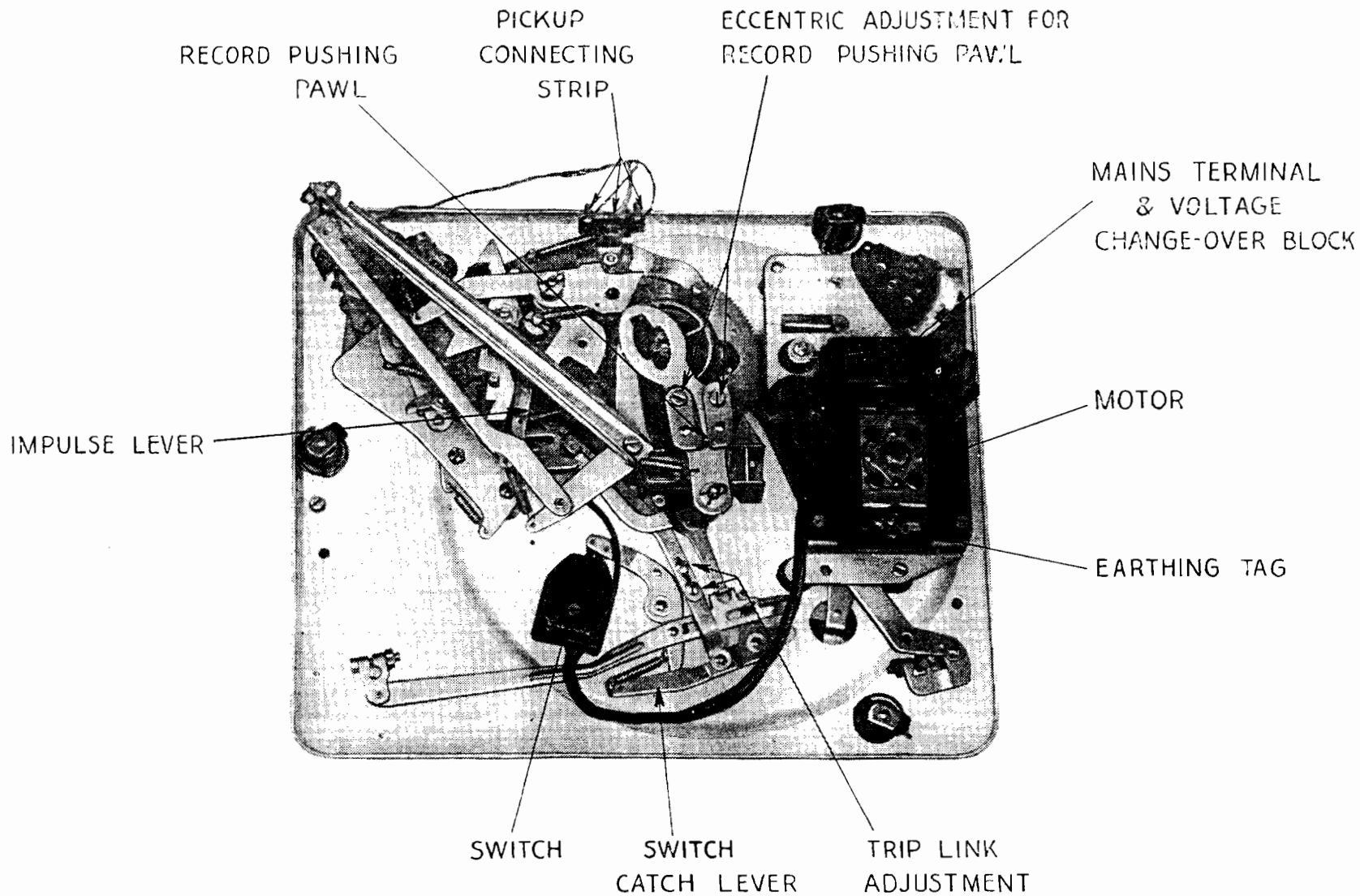

View underneath

Diagram 8

PICKUP.

Two types of stylus are necessary for playing the different types of record, a stylus having a point radius of 0.0025" for standard 78 r.p.m. records and one with a point radius of 0.001" for 33 $\frac{1}{3}$ and 45 r.p.m. To obviate stylus changing, two plug in pickup heads can be used—the R.C.111 will be required to do this—or a turnover type of pickup having two styli can be fitted to either Model R.C.110 or R.C.111.

Should a pickup be used which was not supplied with the changer the pickup stylus pressure, height and dropping position may need resetting.

Care should be taken to see that the correct stylus is in position for the type of record to be played. Turnover pickups are set correctly when the type or speed of record is showing on top of the turnover knob. Should there be an arrow on the knob it indicates the direction to turn it when a change is required.

Some pickups use a colour code to indicate the type of record it is designed to play, green for standard 78 and red for 33 $\frac{1}{3}$ and 45 r.p.m. records.

Should trouble be experienced with the reproduction from a pickup it should be returned to the manufacturer whose name or trade mark appears on the cartridge.

NOTE.

A continuity test cannot be carried out on crystal cartridges with an ohmmeter.

PICKUP TRACKING.

Should there be a tendency for the pickup to track incorrectly, especially on the first record check the stylus pressure and adjust as explained under "Pickup Stylus Pressure" on page 8. Make sure that the flexible screened wire leading to the pickup is not twisted or

held in such a manner as to prevent the free movement of the pickup arm, also see that the associated levers are free.

AUTO TRIP.

The auto trip mechanism is the velocity type, that is, it operates by the quick inward movement of the pickup arm when the pickup reaches the quick run off groove at the end of the record. It is of a special patented design to be very light and sensitive in operation and is set to commence operation when the stylus reaches a 2 $\frac{3}{4}$ " radius. If the auto trip fails to operate the pickup will remain running in the centre of the record and to correct this raise the auto trip lever by giving the adjusting screw for height of auto trip lever, Diagram 5, about half a turn in a clockwise direction, loosening the locknut if one is fitted. This will raise the auto trip lever and enable it to engage the cam on the striker when the pickup runs into the record run off groove.

RECORD DROPPING.

Should records fail to drop first make sure that it is not due to badly warped records. If the records are flat then check that the record pushing pawl is engaging in the record centre hole. The pawl is spring loaded, and after pushing a record off the spindle step it is pushed down by the records above, it is then moved back into the record spindle and when clear of the record above, it should spring up ready to push off the next record. By observing the action of the record pushing pawl, Diagram 8 underneath the changer it can be seen if the pawl is operating as described, if it is not it is probably due to it not moving back quite far enough into the spindle. Adjust this by turning a very small amount the two "Eccentric Adjustment Screws for Record Pushing Pawl," Diagram 8.

Set the adjustment so that there is a very small amount of play between the pawl and the two levers of the adjustment.

SPARE PARTS LIST FOR RC110 AND RC111

The Schedule Number printed on the name plate of the Record Changer is changed whenever a non-interchangeable variation is introduced into the mechanism. It is therefore essential when ordering spare parts to quote the Schedule Number of the Record Changer as well as the Reference Number of the part required.

Name of Part	Ref. No.	Name of Part	Ref. No.
Turntable	B51283	Nut for Terminal Block Cover	A41012
Turntable Mat	C51286	Switch Cover	A51327
Turntable Retaining Clip	A41691	Screw for Switch Cover	A40036
Turntable Mat Centre	A51162	Control Knobs	B51206
Intermediate Wheel with Tyre	A51325	Garrard MPM2 Multi Purpose Plug-in Pickup Case Assembly (less cartridge) with open front for turnover cartridges, for R.C.111	A.52225
Intermediate Wheel Retaining Spring	A41687	Garrard MPM2 Multi Purpose Plug-in Pickup Case Assembly (less cartridge) with closed front for turnround or single purpose cartridges, for R.C.111	A.52226
Intermediate Wheel Retaining Spring Screw	A40012	Large Record Spindle	Type LRS 2
Switch Contact Springs	A41686		
Pulley for 50 cycles	A50897		
Pulley for 60 cycles	A50896		
Pickup Arm R.C.110	B51233		
Pickup Arm R.C.111	B51410		
Terminal Block Cover	A51161		

REPLACEMENT SAPPHIRE STYLI FOR GARRARD PICK-UPS :—

For **Garrard GC2 Crystal Pickup**—

GC2/3 Stylus (Green) for 78 r.p.m. records.

GC2/1 Stylus (Red) for microgroove records.

To obtain the best results and longest life from your Microgroove records, occasionally check the stylus pressure with a **Garrard Stylus Pressure Gauge** obtainable from your dealer.



The **GARRARD**

Stylus Pressure Gauge

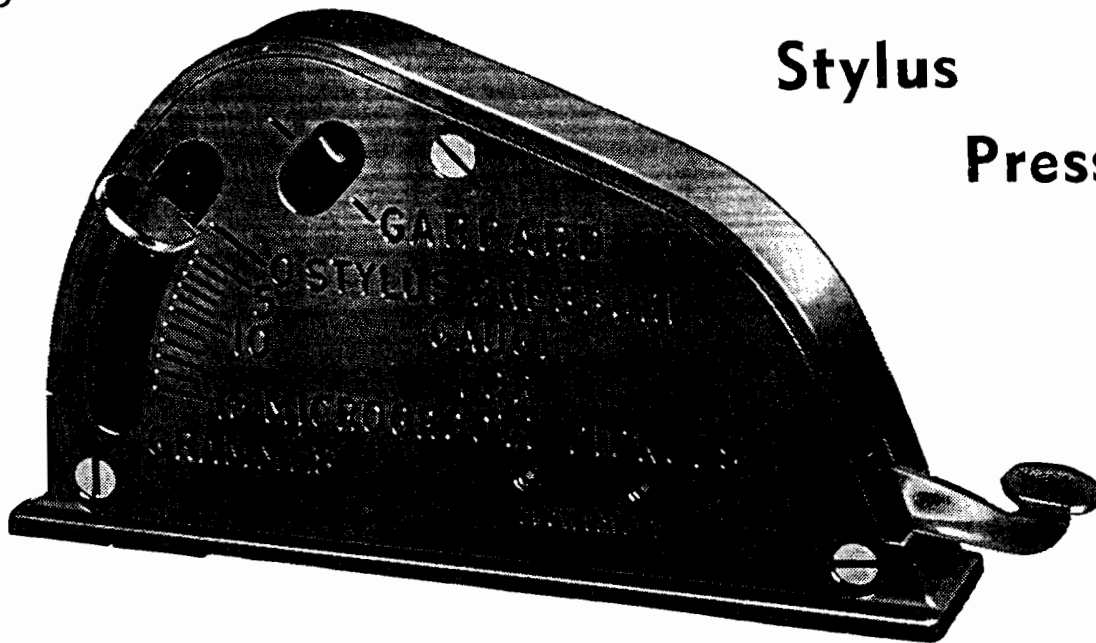

This Gauge, having a range of 0 to 15 grammes, has been produced to meet the demand for a simple, accurate and inexpensive instrument to measure the stylus pressure of pick-ups for playing L.P. Records.

To prevent excessive record wear when playing L.P. records, the stylus pressure should not exceed 10 grammes, and to protect your records the stylus pressure should be checked periodically, the pick-up arm counter-balance being adjusted if necessary.

**EVERY GRAMOPHONE ENTHUSIAST AND RADIO SERVICE MAN
SHOULD POSSESS ONE OF THESE GAUGES**

Garrard
Gramophone Equipment
for
Quality Reproduction

