

Service  
Service  
Service

N1512/00/15

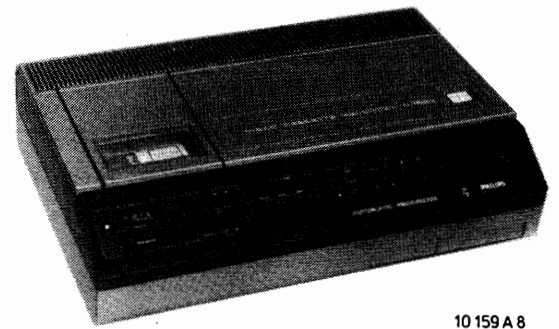

10 159 A 8

# Service Manual

**N1502/00** Is a video cassette recorder with TC-receiver section and electronic timer, suitable for recording and playback of TV-signals according to the CCIR PAL standard. The signals are registered on tape according to the VCR standard.

**N1512/00** Equals N1502/00. However the N1512/00 is also provided with a CVBS input and output.

**N1502/15** Is the same as the /00 version. However, the HF reception and modulator section is adapted to the British TV standard 625 lines system I (sound carrier with respect to picture carrier +6 MHz).  
The mains voltage required is 240 V.

**N1512/15** Equals N1502/15. However, the N1512/15 is also provided with a CVBS input and output.

**N1502/43** Is the same as the /00 version. However, the HF reception and modulator section is adapted to the British TV standard 625 lines system I (sound carrier with respect to picture carrier +6 MHz).  
The built-in channel selector is adapted to the South-African channel range (extended band III).

**N1502/45** Equals the /15 version. However, the channel selector as well as the antenna amplifier are adapted to the Australian channel range.

## CONTENTS

## DATE

II	Descriptions	76-12-01
III	Service adjustments and lubricating instructions	76-10-01
IV	Circuit and wiring diagrams	76-07-15
V	Exploded views and service spare parts	76-07-15
VI	Repair method	76-09-20
VII	Additional Service Information	77-05-16

**CIRCUIT DESCRIPTIONS**

		<b>Page</b>	<b>Date</b>
1. Signal	(circuit diagram A)	11- 3	76-12-01
2. Servo	(circuit diagram B)	11-20	76-12-01
3. Supply - Control and Protection	(circuit diagram C)	11-23	76-12-01
4. Electronic Timer	(circuit diagram D)	11-26	76-12-01

1. SIGNAL

1.1. INTRODUCTION

The N1502/N1512 conforms to the VCR-standard. The VCR standard is based on the 2-head helical scan principle. The tape is wound round a drum to produce a 180° Helical wrap. The drum consists of two parts, one fixed and one rotating. On the rotating part (head disc) 2 video heads are located, mounted at 180° with respect to each other. In sequence, these heads scan the tape diagonally (Fig. II-1). The speed of the head disc is 25 rps. The time of one revolution is 40 m/s, half a revolution takes 20 m/s. Because a TV-frame also takes 20 m/s, it follows that on every revolution each video head modulates just one frame on the tape.

In Fig. II-1 is schematically shown where the video tracks, the audio tracks and the sync track are modulated on the tape. Also visible in this figure is the relation between the spot where the frame pulse is modulated on the tape and the position of the picture gap on playback. The sync track determines the place of the video tracks on the tape. These 25 Hz pulses are written across the video tracks in the shape of needle pulses. The spot where these pulses are modulated on the tape corresponds with the spot where also the frame blanking of the video signal is modulated. As a consequence, these sync pulses, which are read as interference pulses by the video heads, do not cause interference on the TV-screen. The VCR system provides for 2 audio tracks. In the sets N1502/N1512 only audio track 1 is used. This track is modulated on the bottom tape edge.

1.2. BASIC DATA VCR-SYSTEM

1.2.1. Mechanical basic data

- Drum diameter : 105 mm
- Speed head disc : 1,500 rpm
- Scanning speed (relative speed video head/tape) : 8,1 m/sec
- Tape speed : 14,29 cm/sec
- Gap length of the video head : 0.8 μm
- Video track width : 130 μm
- Distance between 2 video tracks : 57 μm
- Audio track width : 0.7 mm
- Sync. track width : 0.3 mm

TRACKCONFIGURATION OF VCR-SYSTEM (50 Hz)  
(NOT DRAWN TO SCALE)

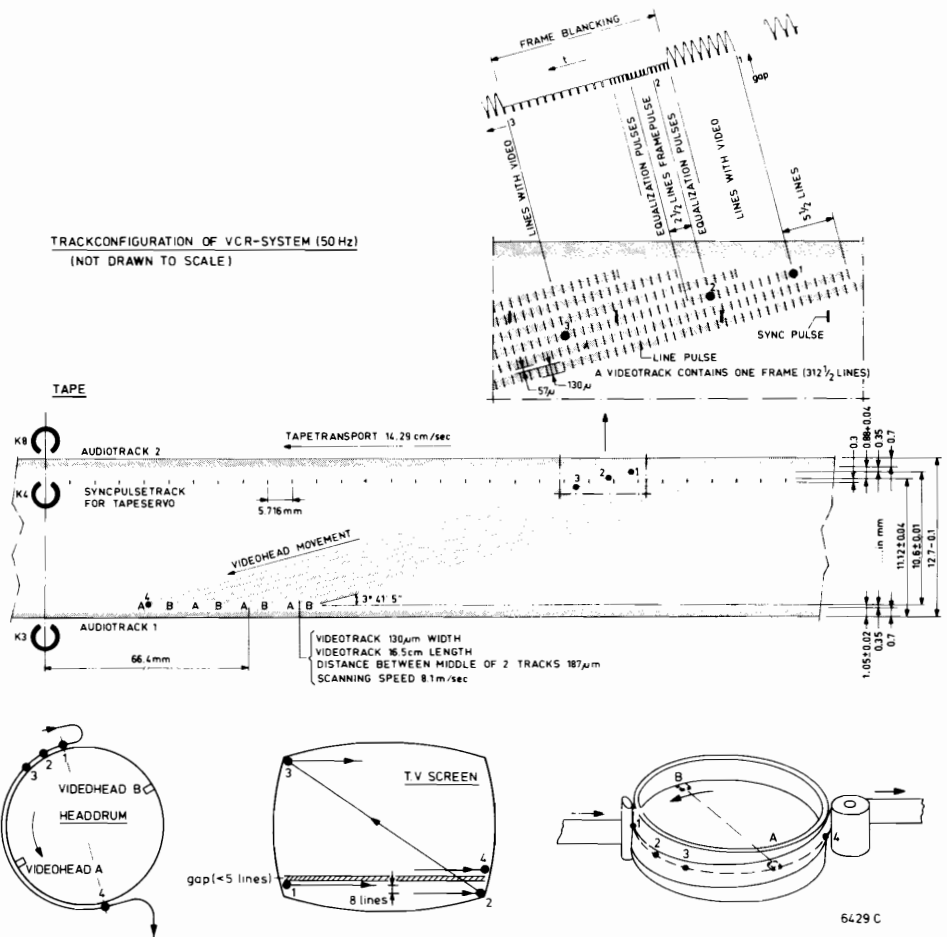

### 1.2.2. Modulation system

The VCR modulation diagram is shown in Fig. II-2. Explained in the following text is how this modulation diagram was made:

- The highest frequency the video heads can playback at the given scanning speed of 8,1 m/sec is approx. 5 MHz.
- With a view to the picture quality, the luminance signal is converted into an FM signal
- To obtain sufficient signal/noise ratio on demodulation of the FM-signal, the FM sweep must be abt. 1.4 MHz.
- When recording, to avoid interferences, no video signals with a frequency higher than the minimum frequency of the FM-carrier (3 MHz) may be fed to the FM-modulator.

From the above, it follows that the chrominance signal must be modulated on the tape via another way.

- The FM sidebands in the frequency range between 0 and 1 MHz are not so important for the luminance signal. This offers the possibility of placing the chrominance signal in this frequency range. By means of mixing, the chrominance signal is transposed to this frequency range.
- The amplitude of the luminance signal modulated in FM is much greater than the amplitude of the transposed chrominance signal. As a result, the FM signal functions as premagnetization signal for the chrominance signal.

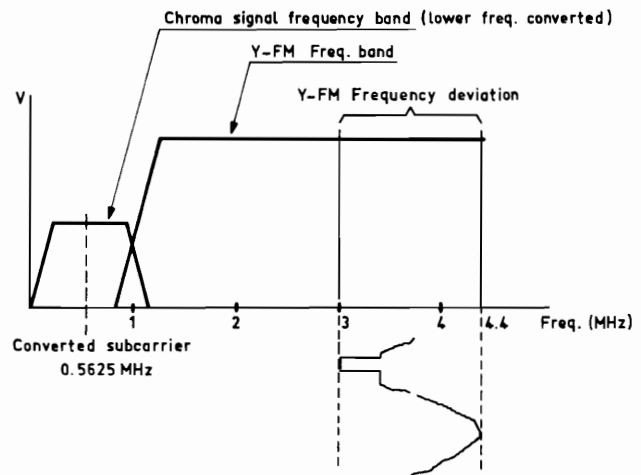

1201A

Fig. II-2



### 1.3. DESCRIPTION OF THE BLOCK DIAGRAM

#### 1.3.1. Introduction

Prior to describing the circuit diagram of the signal section (diagram A), a simplified block diagram of the recording and playback section will be discussed. Above the blocks, unit numbers are mentioned. These numbers refer to units in circuit diagram A, in which the relevant block (function) is applied.

The blocks that are hatched, function in recording and playback position.

#### 1.3.2. Recording (Fig. II-3)

The aerial signal, applied to input BU2, is fed to aerial amplifier U552.

After the first stage of amplification in this unit, this aerial signal is split and fed to the combined VHF/UHF tuner and after a second stage of amplification it is fed to the O/P socket BU3 via a combining network.

With drawer U20, the channel selector is pre-selected. The 8 selector push buttons are located on panel 31.

Via the IF amplifier U505 the signal of the transmitter selected is fed to the detector unit U506.

This unit produces the detected luminance and chrominance signal and the 5,5 MHz IF sound signal.

##### *Luminance*

The luminance signal is applied to the FM modulator in U701 via a low-pass filter in U507 and a control amplifier in U511. By means of this low-pass filter, the signal is limited to a bandwidth of 3 MHz. In the FM modulator the luminance signal is converted into an FM signal. The sweep is 1.4 MHz and lies in the frequency spectrum between 3.15-4.55 MHz (Fig.II-2). According to the VCR standard the sweep must lie between 3 and 4.4 MHz  $\pm$  150 kHz. From this it follows that the sweep for this set is adjusted to the highest tolerance limit.

In an adder circuit in U701, the FM luminance signal and the 562.5 kHz AM chrominance signal - to be described later on - are added together and then applied to the video heads K1, K2 via the writing current amplifier on p.c. board 90 and the rotating transformer S1, S2.

##### *Chrominance*

As it is known, the 4.43 chrominance signal, on recording, must be transposed to a lower frequency range (0-1 MHz). This is done by the mixer in U514E. The 4.43 MHz chrominance signal from the detector unit U506 and a 4.99 MHz oscillator signal artificially obtained, are applied to this mixer.

On the output of the mixer 2 mix products are filtered out:

- The original 4.43 MHz chrominance signal, via a 4.43 MHz band-pass filter
- The 4.99-4.43 = 0.5625 MHz chrominance signal required, via a low-pass filter.

As discussed already, the 562.5 kHz signal is added to the luminance signal modulated in FM, in U701.

##### *4.99 MHz oscillator signal*

As described earlier, the 4.99 MHz oscillator signal is required for transposing the 4.43 MHz chrominance signal to a higher frequency range.

The 4.99 MHz signal is obtained by mixing an oscillator signal of 562.5 kHz with an oscillator signal of 4.43 MHz in a second mixer in U515E.

The sum of these 2 signals is the 4.99 MHz signal required.

The 562.5 kHz signal is supplied by a 562.5 kHz oscillator in U512E. The frequency of this oscillator is controlled by a phase discriminator, to which the line sync pulses of the luminance signal are applied.

The 4.43 MHz signal is produced by a 4.43 MHz local oscillator. The frequency of this oscillator is controlled by a phase discriminator to which the burst frequency of the chrominance signal is supplied as reference.

It follows from the above that the 4.99 MHz signal is coupled with the line frequency and with the burst frequency of the transmitter signal, ensuring great stability of the 4.99 MHz signal.

##### *Sound*

The 5.5 MHz IF sound signal (6 MHz for /15/43) is filtered by S504 and then amplified and demodulated by U508. Via the recording amplifier with automatic recording level circuit in U509, the signal is applied to U510.

The erase oscillator is part of U510. The premagnetization current for the sound signal, as usual, is supplied by the erase oscillator. The sound is modulated on the tape by audio head K3.

##### *UHF modulator*

In order to check, whilst recording, to which channel the channel selector is tuned, the detected luminance and chrominance signals are applied to the UHF modulator U551 via an adder circuit in U511. Also the modulated sound signal is applied to the UHF modulator. These three signals are modulated on an RF carrier (approx. channel 37) and, just like the aerial signal, supplied to the aerial output BU3 via the combining unit in the aerial amplifier U552.

#### 1.3.3. Playback (Fig. II-4)

In playback position, the signal, induced in the video heads K1, K2 is applied to the preamplifier (on p.c. board 90) via the rotating transformer S1,S2. After the preamplifier, the signal is applied to a high-pass and a low-pass filter.

##### *Luminance*

After the high-pass filter in U702E, only the FM luminance signal remains. Next, the FM signal is demodulated in U703. The output of the FM demodulator is connected to an electronic switch. Normally, this switch will be in the position drawn, so that the undelayed luminance signal is passed on.

##### *Drop-out compensator*

The function of the drop-out compensator is filling up a drop-out, i.e. a short signal interruption.

A second FM demodulator U704 serves this purpose. To this FM demodulator the signal, delayed by 64  $\mu$ s, which equals a line duration, is applied. When a drop-out occurs in the signal produced, it will be recognized by the drop-out detector in U702E.

This drop-out detector gives a pulse, so that the electronic switch in U703 switches over. The signal originating from the FM demodulator in U704 will now be passed on.

Thus, the drop-out is filled up by the information of the preceding line. As in most cases the information of 2 subsequent lines will practically be the same, the drop-out will be invisible. The signal of the drop-out detector in U702E also causes an electronic switch in U704 to switch over. As a result, the output of the delay line is interconnected with the input. Consequently, it is also possible to fill up drop-outs longer than 64  $\mu$ s, because the last correct line is repeated again and again. Following the electronic switch in U703, the signal is applied to a so-called crispening unit U721. In this unit, the signal is affected in such a manner that the signal steps in the picture artificially obtain a sharper edge resulting in a sharper picture on the screen.

In the low-pass filter in U507 all frequencies higher than the luminance playback range (3 MHz) are suppressed. Next, the luminance signal is applied to the adder circuit in U511.

#### *Chrominance*

After the low-pass filter S703, S704, C702-C707 only the 562.5 kHz chroma signal remains. By means of the mixer in U514E, this signal is transposed again to the original 4.43 MHz with the help of the 4.99 MHz oscillator signal which is also present on playback. Via the 4.43 MHz band-pass filter, in which the other mix products are suppressed, the 4.43 MHz chrominance signal is likewise supplied to the adder circuit in U511.

#### *4.99 MHz oscillator signal*

In playback position, the 4.99 MHz oscillator signal is obtained in the same way as in the recording position. Now, the line pulses of the playback/luminance signal are supplied as reference to the phase discriminator controlling the 562.5 oscillator. In playback position, the 4.43 oscillator is free running. Using the mixing method described above ensures that, independent of speed variations of the video disc, a stable 4.43 MHz carrier for the chroma is obtained.

This is explained as follows:

As it is known, the relative scanning speed is not constant, but will always vary slightly.

The frequency of the playback signal proportionally co-varies to the same degree.

Assuming that the scanning speed is 1 % too high, then the frequency of the colour sub carrier induced in the video heads will also be 1 % higher and will be  $562.5 \text{ kHz} + 1 \% = 562.500 \text{ Hz} + 5625 \text{ Hz}$ .

Because the 562.5 kHz oscillator in U512E is

driven by the line pulses of the playback luminance signal, this oscillator also starts oscillating at a frequency 1 % higher. The oscillator frequency is then  $562.500 \text{ Hz} + 5.625 \text{ Hz}$ . After mixing with the 4.43 oscillator signal, the 4.99 MHz oscillator signal is also increased by 5.625 Hz. The mix product difference between chrominance and oscillator signal after the mixer in U514E then is  $(4.99 \text{ MHz} + 5.625 \text{ Hz}) - (562.5 \text{ kHz} + 5.625 \text{ Hz}) = 4.43 \text{ MHz}$ .

It follows that, independent of the variations in scanning speed, there is always a chrominance signal with a stable 4.43 MHz carrier available on the output of the mixer in U514E. The deviation of the free-running frequency of the 4.43 MHz oscillator TS504 with respect to the exact burst frequency is not compensated for, and this deviation must be accepted by the subcarrier oscillator in the TV-set connected.

#### *Sound*

The audio signal induced in the audio head k3, on playback, is amplified in the units U510 and U509 and then applied to the 5.5 MHz audio modulator in U551.

#### *Modulator*

In the modulator U551 the composite luminance and chrominance signals together with the sound signal (which has been FM modulated onto a 5.5 MHz carrier) are modulated onto a RF carrier (channel 37) and, next, applied to the aerial output BU3 via the combining circuit in U552.

In the N1502/00/43 and N1512/00/43, also the aerial signal on BU2 is applied to the aerial output BU3 via the aerial amplifier.

### BLOCK DIAGRAM SIGNAL "RECORDING" N1502

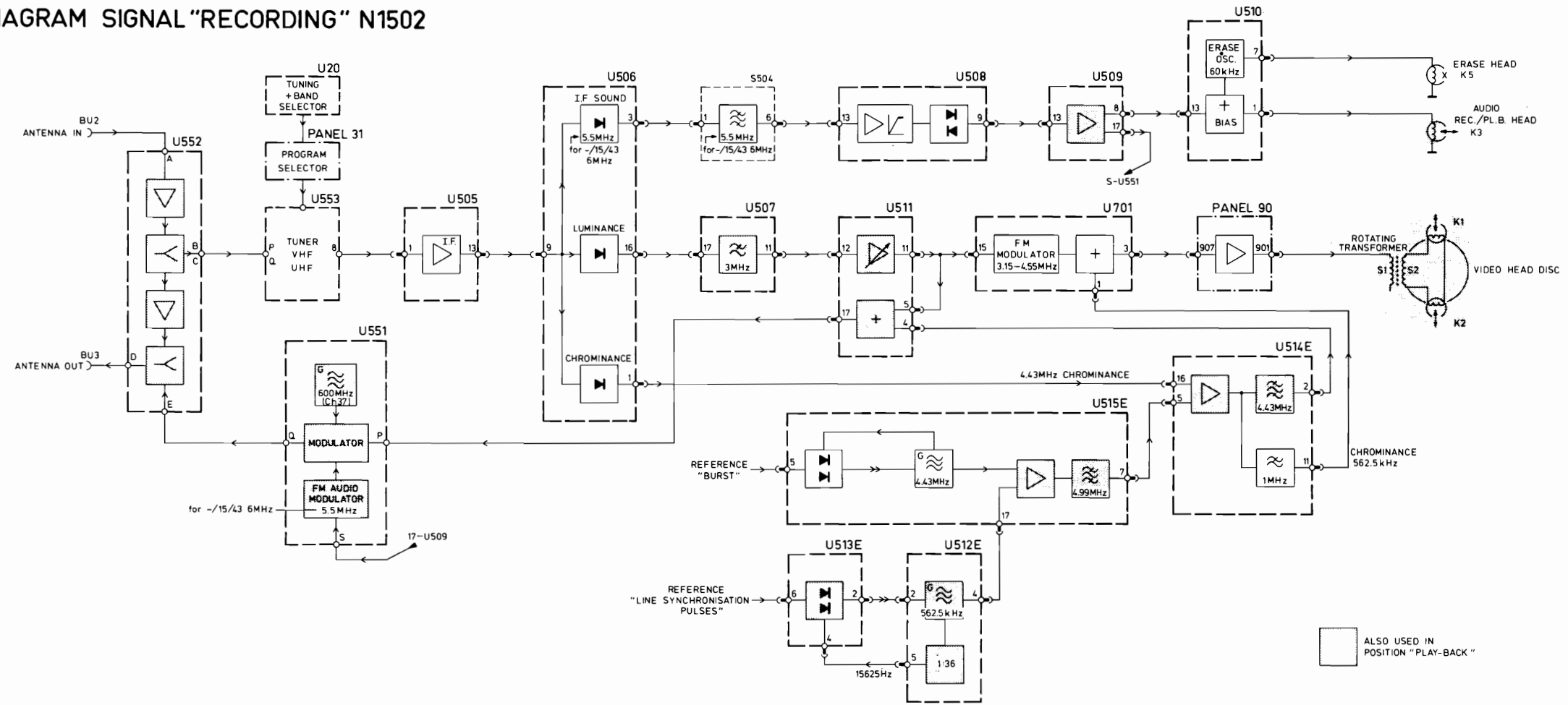

Fig. II-3

### BLOCK DIAGRAM SIGNAL "PLAY-BACK" N1502

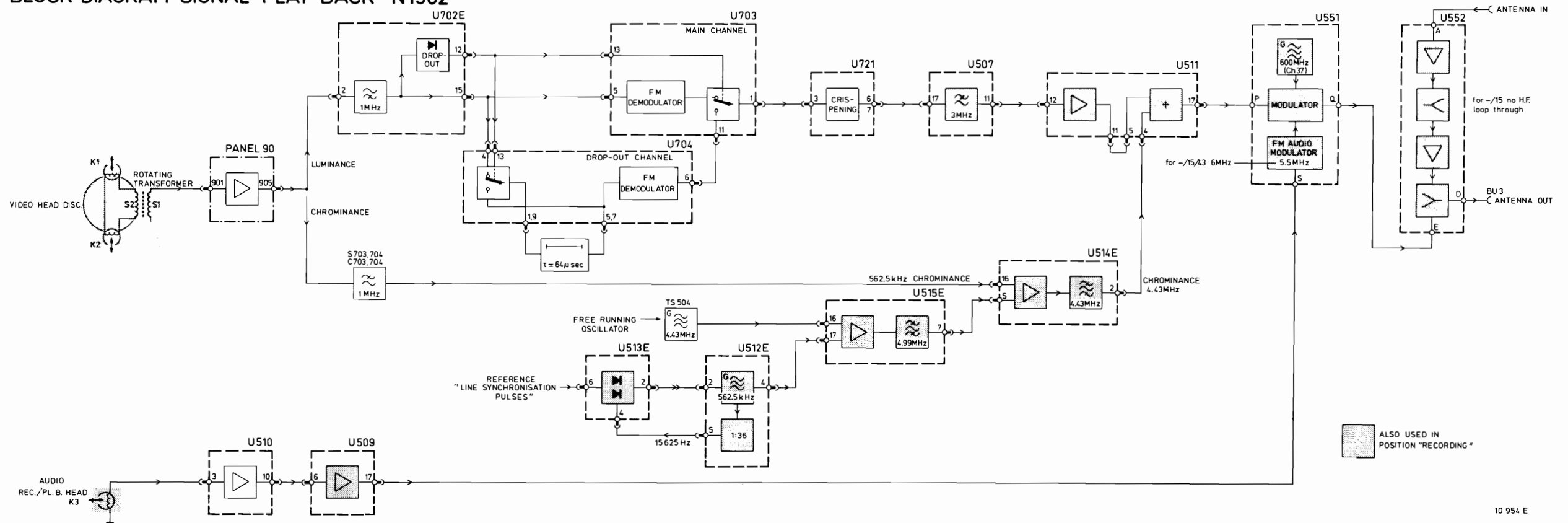

Fig. II-4



#### 1.4. DESCRIPTION OF THE CIRCUIT DIAGRAM OF THE SIGNAL SECTION IN RECORDING POSITION

##### 1.4.1. Introduction

In circuit diagram A the main signal paths in recording position are marked with a solid, violet line. The dotted, violet/green line marks the main signal paths common to recording and playback.

##### 1.4.2. Aerial amplifier U552

The aerial signal is applied to the aerial amplifier U552 via BU2. Before the signal is applied to the first amplification stage, all frequencies under band I are suppressed by a high-pass filter. The second filter suppresses the FM band. The aerial signal is applied to the aerial output BU3 via a splitter, a second amplifier and an aerial signal combining circuit.

The loop gain for band I and III is  $2 \pm 2$  dB and for band IV and V  $0 \pm 2$  dB.

After the first splitter the signal is applied to the VHF input via a low-pass filter and to the UHF input of the channel selector U553 via a high-pass filter.

##### 1.4.3. Channel selector U553

U553 is a combined VHF/UHF channel selector with varicap tuning and electronic band switching.

Bands:

- /00/15 version (ELC2000)

Band I 47-88 MHz

Band III 174-230 MHz

Bands IV, V 470-862 MHz

- /43 version (ELC2070)

Band III 174-254 MHz

Bands IV, V 470-862 MHz

The VHF section of the channel selector contains an RF gain controlled amplifier, a separate oscillator and a mixing stage. The UHF section contains an RF gain controlled amplifier and a self-oscillating mixing stage. Moreover, in UHF position, the VHF mixing stage functions as an amplifier.

The collector of this amplification stage contains a tuned IF circuit, across which the IF signal is disconnected in a capacitive manner.

The switching over of the channel selector to VHF position (band I or III) and to UHF position (band IV and V) is effected by feeding supply voltage to the relevant tuner connections. This supply voltage is applied to the channel selector from the plug connection L63 (+5B) and via the contacts of SK311a...SK317a, and the band switches in drawer U20.

The diodes D503-D506, in combination with the band switch, take care that, in the band switch position selected, the supply voltage required is applied to the relevant channel selector connections:

In VHF position (band I) points 1, 4 and 5

In VHF position (band III) points 1, 3, 4 and 5

In UHF position (bands IV, V) points 3, 10, 12, 13

In both VHF and UHF position, the tuning voltage is applied to point 2 of the channel selector.

The main tuning voltage is applied to point 2 from the +8, via trimming potentiometer R507 and one of the 8 potentiometers in drawer U20, the channel selector switches SK311b-SK317b, plug connection L62 and R504.

The Phaft voltage for automatic tuning is likewise applied to U553 point 2, via R505. For the description of the automatic tuning, see chapter 1.4.7.

##### 1.4.4. IF amplifier U505

The IF signal is applied to U505 point 1.

This unit contains a combination of filters and a 2-stage gain controlled amplifier. The combination of filters mainly serve for the selectivity of the IF section.

The filter combination gives the following suppressions:

31.9 MHz in /00/43 version	adjacent sound carrier
30.9 MHz in version /15	carrier

33.4 MHz in /00/43 version	sound carrier wave proper
32.8 MHz in /15 version	

40.4 MHz in /00/43 version	adjacent sound carrier VHF
40.9 MHz in /15 version	

41.4 MHz in /00/43 version	adjacent sound carrier UHF
41.5 MHz in /15 version	

Suppression is effected before the gain controlled amplifier, to prevent cross-modulation. The two-stage amplifier is forward gain controlled.

The control voltage is applied to points 3 and 9 of the unit. The control range is 40 dB. Capacitor C507 is a smoothing capacitor for the supply voltage.

##### 1.4.5. IF detector U506

The IF detector supplies the following signals:

- On point 16 the detected luminance signal

- On point 1 the detected chrominance signal

- On point 3 the 5.5 MHz (intercarrier) IF sound signal

The IF signal applied to U506 point 9 is amplified once again. Next, it is applied to the luminance and chrominance detector.

###### *Luminance detector*

Before the signal is applied to the luminance detector, the 33.4 MHz is once again specially limited, to ensure that the sound carrier will not cause any interference in the detected luminance signal. Moreover, this circuit is necessary for obtaining the Phaft automatic tuning voltage in U508. The detected luminance signal is applied to U506 point 11 via an emitter follower. The amplitude of the luminance signal on 16U506 is determined by the external DC-voltage on 13U506. This DC-voltage is produced by voltage divider R530/R531.

###### *Chrominance detector*

Chrominance detection is carried out by the base emitter junction of a transistor. From the collector of this transistor, the detected chrominance signal is applied to U506 point 1.

###### *IF sound*

Because of the non-linear characteristic of the base-emitter transition of the chrominance detector, between the 38.9 MHz picture and the 33.4 MHz sound carrier, various mix products occur. The difference between these 38.9 and 33.4 MHz (5.5 MHz) is used as IF sound signal. This signal is available on 3U506.



#### 1.4.6. AGC U507

##### *MF + RF AGC*

To prevent the RF amplifiers in the channel selector and the IF amplifier in U505 from being overdriven, a control voltage must be applied to these amplifiers, dependent on the amplitude of the aerial signal. This control must also ensure that the amplitude of the detected luminance signal on 16U506 remains constant.

##### *IF - AGC*

The luminance signal on the detector output 16U506 is applied to 17U507. The amplitude of the sync pulses in the luminance signal is a reference for the amplitude of the transmitter signal. These sync pulses are rectified by a tip detector in U507. The DC-voltage thus obtained (control voltage) is applied to U505 points 3 and 9, via 5U507.

##### *RF - AGC*

The RF AGC comes into operation only, when the IF AGC is not sufficient any more. Via U507 point 1 and diode D507 a control voltage is then applied to the RF amplifier in the VHF section of the channel selector and, via diode D502, to the RF amplifier in the UHF section of the channel selector.

#### 1.4.7. IF sound + Automatic tuning unit U508

##### *IF sound*

The 5.5 MHz IF sound signal, as discussed already, is available on 3U506. In the 5.5 MHz filter S504 the signal is filtered once again and then applied to U508 points 13 and 12. In this unit, the signal is amplified, limited and next, via an electronic switch, applied to an FM detector. The detected sound is available on 9U508. The electronic switch is opened when 17U508 is not supplied with voltage. This is the case when the combined audio socket BU504 is used. SK504, mechanically coupled with BU504, is then opened, disconnecting the sound signal or noise signal from 9U508. Now, an audio recording can be made via an external audio source (e.g. in case of TV-camera shootings).

##### *Phaft (Phase automatic fine tuning)*

U508 also contains the Phaft detector.

##### *Introduction*

The Phaft detector supplies a control voltage to the channel selector, so that the tuning, within certain limits, remains optimal. As reference for the correct tuning the frequency of the sound carrier is used. Two 5.5 MHz IF-sound signals are applied to the Phaft detector in U508. The first one originates from the IF sound section in U508, just discussed. The second one originates from 16U506. For in the luminance detector, on account of the non-linear diode characteristic, a mix product of 5.5 MHz has been formed by the picture sound carrier mixing. This 5.5 MHz signal, just like the 5.5 MHz IF sound signal already discussed, is filtered (S505), amplified and limited in U508 and, next, applied to the phase detector, via an electronic switch. The sound carrier, from which this second 5.5 MHz signal originates, has received supplementary suppression in the 33.4 MHz rejection filter, just before the luminance detector in U506. This circuit has a high quality factor and is carefully adjusted at 33.4 MHz. If the tuning of the channel selector is correct (without automatic tuning voltage) this circuit will behave as a resistive reactance on the sound carrier producing no phase shift, because, in this case, the frequency of the sound carrier is also 33.4 MHz. If the channel selector is wrongly tuned, the sound carrier will have a frequency higher or lower than 33.4 MHz. The 33.4 MHz circuit, in this case,

functions in an inductive or capacitive manner resp. so that the sound carrier gets extra phase shift. This phase shift, after mixing in the luminance detector with the picture carrier, is retained in the mix products, so that also the 5.5 MHz signal has this extra phase shift. Consequently, if the channel selector is wrongly tuned, the two 5.5 MHz signals which are applied to the automatic tuning detector in U508, will differ in phase. The difference is converted into a proportional DC-voltage by the phase detector. Because the automatic tuning control voltage is added to the tuning voltage, it must be possible for the control voltage to be positive or negative. The output voltage of the automatic tuning detector is therefore applied to a DC-voltage amplifier receiving positive and negative supply voltages. Via the automatic tuning output 2U508 the control voltage, via R501, emitter follower TS507 and R505, is added to the tuning voltage on 2U553. As a result, the channel selector is properly tuned to the transmitter again. Any possible sound modulation present in the automatic tuning control voltage on the output of 2U508, is suppressed by C501.

##### *VHF/UHF switching*

In the UHF range, the channel selector has a far greater tuning slope than in the VHF range. This would mean that, with the same automatic tuning control voltage, the pull-in range of the automatic tuning in the UHF range would become too great. Therefore, the amplitude of the automatic tuning control voltage in UHF position is reduced. This is effected by supplying the voltage to U508 point 15, in UHF-position, via a larger resistor (R509) than in VHF-position (R508). As a result, the amplification of the 5.5 MHz amplifier is reduced, so that also the maximum automatic tuning voltage is reduced. In VHF-position, the maximum automatic tuning voltage is 7 V. In UHF-position, the maximum output voltage is reduced to approx. 2.3 V.

##### *Delay in switching-on the automatic Phaft tuning circuit*

In order to avoid capturing the wrong transmitter when switching on the VCR. The Phaft circuit is delayed by C502, R502, D501 and the electronic switch in U508.

##### *Working*

When the receiver is switched-on, C502 is still uncharged. This elco is charged via R502 and a resistor located in U508. This resistor is connected to earth. As long as current flows through R502, the electronic switch will be open, and the automatic tuning channel is cut-off. When elco C502 is charged, there will be no more current through R502 and the electronic switch is closed. The RC time of C502, R502 and the resistor in U508 is 5 sec. Diode D501 providing quick discharge of C502 when the +5A supply voltage drops off.

In two cases, the automatic tuning voltage must be short-circuited:

1. When switching over to another channel. In this case, the automatic tuning voltage built-up in the previous position, must be quickly discharged to ensure correct reception on the new channel. This is done by SK319. This switch is mechanically coupled with the channel selector push-buttons and is closed when one of these buttons is pressed (pressed through). With SK319 closed, the automatic tuning output 2U508 is connected to earth via R501 and SK319.
2. When adjusting the tuning controls in the drawer. This is done by SK18, connected in parallel to SK319 and mechanically coupled with drawer U20. When drawer U20 is opened, SK18 is closed and

the automatic tuning output voltage is also short-circuited to earth.

#### 1.4.8. Signal preparation U511

In order to check to which channel the channel selector is tuned, the detected luminance and chrominance signals, on recording, are added together again and applied to the UHF-modulator U551. The modulator signal, via the aerial amplifier U552, is also applied to aerial output BU3. U511 has the following functions:

- Supplying a signal of proper amplitude polarity and DC-voltage level to the luminance recording section U701 and to the modulator U551.
- Combining the luminance and chrominance signals again in the right proportion.
- Providing the signal with new sync pulses
- Adding a VCR identification pulse to the line sync pulse.
- Preventing overmodulation in the modulator U551 with consequent sound interferences.
- Providing the signal applied to UHF-modulator U551 with a group delay time pre-correction (/00 version only).

The detected luminance signal on 16U506 is applied to 12U511 via a 4.43 MHz rejection filter and a low-pass filter, both contained in U507.

The necessity of these two filters will be discussed in the luminance recording section U701.

Between points 12 and 11 of U511 the luminance signal is amplified and inverted. From 11U511, the signal is applied to the FM modulator unit U701 and, via R517, TD501 and R518 to U511 again. TD501 gives a delay of 540ns for compensating the difference in group delay times of the luminance and chrominance signals on the adding point in U511.

R517 and R518 are terminating resistors for the input and output of the delay line.

The chrominance signal, amplified in U514E, is applied to 4U511. The luminance/chrominance signal combined in U511, is provided with a new sync signal, clamped to black level and having a VCR identification pulse. In all these cases, the original sync signal which, in U513E, has been separated from the luminance signal, is used as reference.

The sync signal is applied to 2U511. On 14U511, a CVBS signal is available. Next, via group delay time pre-correction and an emitter-follower, the signal is applied to modulator output 17U511.

The CVBS-signal on 14U511 is also, applied to the Y-AGC control within the unit.

##### Y-AGC control

The Y-AGC control comes into operation as soon as the white level in the luminance signal exceeds the 100 % white value. From that part of the signal lying over the 100 % white level, a control voltage is derived, which is applied to the gain controlled amplifier, and its amplification is quickly reduced.

Necessity of this control:

As it is known, the carrier amplitude, in case of negative modulation, diminishes as the amplitude of the signal to be modulated increases.

At 100 % white, however, 10 % carrier must remain to prevent interference in the sound. The Y-AGC control takes care that sufficient carrier is always present.

##### VCR-identification

It is known that the time constant of the line synchronization circuit of the TV set must be adapted to playback a VCR signal in order to obtain a stable picture reproduction. In the present CTV chassis, like K9 and K11, this was achieved by a built-in cable. If the highest numbered channel

selector push-button is pressed, the line sync circuit is adapted. Quite a number of versions already have this cable as a standard device. On the TV-set, it is indicated by VCR or VCR/VLP. Recently a development has taken place to the effect that the signal, originating from a VCR, is provided with a VCR-identification signal. This signal is detected by a VCR-identification detector in the CTV receiver. The output signal of the detector automatically adapts the line sync circuit, independent of the channel selector push-button chosen. The VCR identification signal consists of a pulse, which is added to the line sync pulse. In Fig. II-5 the place of this pulse in the signal is shown.

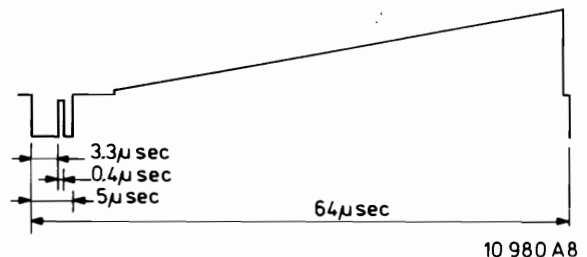

Fig. II-5



*Group delay-time pre-correction*

According to the PAL BG system, a signal transmitted must comply with a given group delay-time pre-correction. The phase characteristic of the group delay-time pre-correction filter is shown in Fig. II-6.

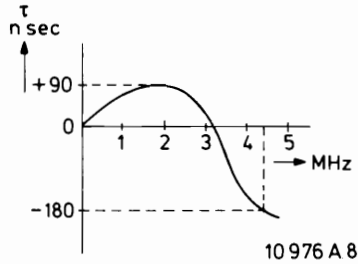

Fig. II-6

**1.4.9. UHF-modulator U551**

The CVBS signal and the audio signal are modulated on a RF carrier by the UHF modulator U551, and, then applied to the output socket BU3 via a signal combining circuit in U552. The carrier frequency has been adjusted by the factory at 600 MHz, which corresponds with channel 37. If so required, the carrier can be detuned  $\pm 5$  channels. The CVBS signal is applied to point P, the audio signal to point S of the unit. Before the audio signal is applied to the main modulator, it is FM modulated on a 5.5 MHz carrier within U551.

*Switching-off delay TS501, TS502*

To prevent the annoying loud noise that occurs when the signal to a CTV is interrupted, for example when earlier version VCR's were switched off, it has been arranged for the modulator to remain on for 20 seconds after the VCR has been switched off.

*Working of the switching-off delay*

After switching off the set, the +1A supply voltage drops off, the +1 supply voltage remains. Now, elco C506 will only be discharged via TS502, because diode D510 is cut-off. After approx. 20 seconds, C506 is discharged. TS502 ceases to draw base current and is cut-off. Also TS501 will then block. As a result, the supply voltage on the modulator unit points C, E and F is interrupted.

**1.4.10. Luminance FM-modulator U701**

Before the luminance signal is applied to the FM-modulator in U701, it must be limited to 3 MHz in bandwidth. The reason why has been explained already in the discussion about the VCR modulation diagram.

This limitation in bandwidth is effected by the low-pass filter in U507. The 4.43 MHz rejection filter removes any chrominance signal remaining on the detected luminance signal. The all-pass filter, added to the low-pass filter, compensates for the differences in delay time originating from the low-pass filter. The combined effect of the total delay time of 440 nsec is that the luminance signal modulated in FM and the transposed chrominance signal with the same delay times are added in U701. Via the plug connections L55 and F45, the signal, limited in bandwidth and controlled in amplitude, is applied to the FM modulator in U701.

*FM modulator*

The luminance signal is converted to FM in the FM modulator, a sweep width of 1.4 MHz corresponds to peak white, and the frequency spectrum of the modulator is 3.15 to 4.55 MHz (Fig. II-8).

The spectrum is therefore 150 kHz higher in frequency than in preceding VCRs. However, this recorder still conforms to the VCR standard, as stated earlier when describing the block diagram.

By adjusting the FM sweep to be as high as possible, the frequency range of the low FM sideband is increased by 150 kHz, resulting on playback in an increase of 150 kHz in definition of the reproduced luminance signal.

Before the luminance signal is FM modulated, it undergoes the usual preparations, such as:

- The signal is clamped on sync top level
- The signal is submitted to the video pre-emphasis
- The signal is submitted to a black and a white clipper (Fig. II-8).

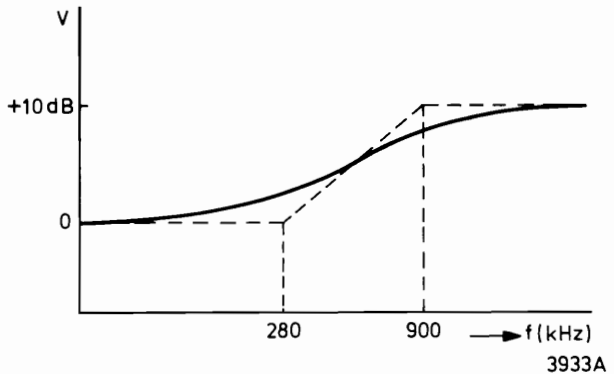

Fig. II-7

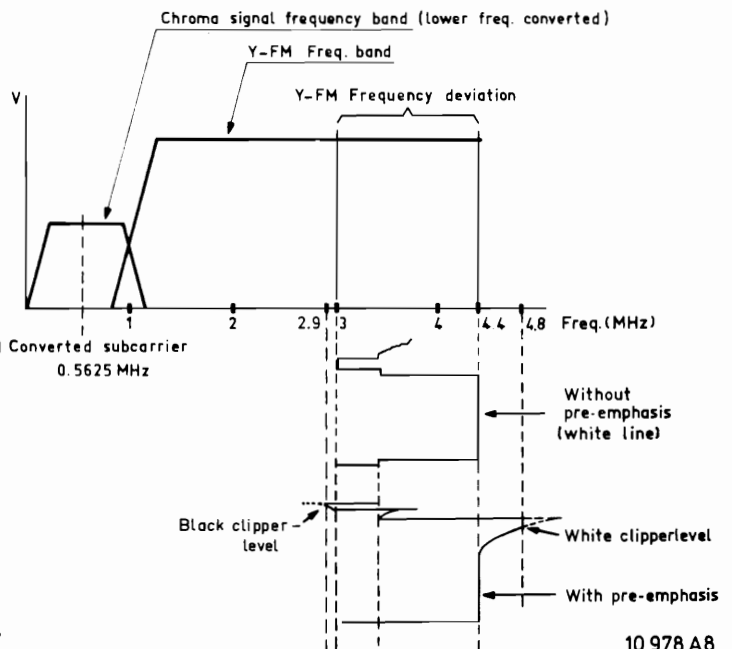

Fig. II-8

**Remark:**

The black clipper is incorporated in a VCR for the first time. The black clipper ensures that the overshoot of the pre-emphasis effect does not cause the FM carrier to be momentarily driven too low - thereby interfering with the lower frequency chrominance signal.

After the FM modulator, the signal is limited, to remove AM modulation from the FM signal.

Via a preset control used to adjust the luminance writing current, the signal is applied to the input of an amplifier. Also the downwards transposed chrominance signal is applied to this same input. Next, the added signals are applied to the writing current amplifier on p.c. board 90, via the amplifier mentioned before.

Before discussing the writing current amplifier, the chrominance recording section will be described.

**1.4.11. Chrominance AGC + recording mixer, U514E**

As it is known already, for recording the detected chrominance signal with a carrier frequency of 4.43 MHz, is transposed to a lower frequency band with a new 562.5 kHz carrier. The detected chrominance signal on 1U506 must first be slightly limited in bandwidth. This is done in circuit S503, C517, which is adjusted to 4.43 MHz. Via emitter follower TS503, the signal is applied to the gain controlled amplifier in U514E. Here, the chrominance signal is amplified to a constant burst amplitude. The control voltage is supplied by U515E. Next, the controlled signal is applied to the recording mixer. Also a 4.99 MHz oscillator signal is applied to this mixer via 3U514E. This signal also originates from U515E.

At the mixer output, two mix products are filtered out:

1. The original 4.43 MHz chrominance signal
2. The difference in mix products 4.99 MHz - 4.43 MHz = 562.5 kHz chrominance.

The original 4.43 MHz chrominance signal is applied to the burst gate in U515E via 13U514E and to the adding point in U511 via 2U514E.

The 562.5 kHz chrominance signal is applied to 1U701, via 11U514E, the plug connections L36 and F36 and trimming potentiometer R710.

Then, as was previously mentioned, this signal is added to the FM luminance signal.

The chrominance writing current is adjusted with R710.

**1.4.12. 4.99 MHz processor + chroma AGC voltage former U515E**

U515E supplies the following signals:

- On 7U515E, the 4.99 MHz oscillator signal
- On 4U515E, the AGC voltage for the chroma gain controlled amplifier in U514E
- On 9U515, the colour killer voltage.

*The 4.99 MHz oscillator signal*

This signal is produced by applying a 4.43 MHz and a 562.5 kHz oscillator signal to the mixer in U515E. The sum of these two signals is the 4.99 MHz signal required. With a filter, this signal is separated from the other mix products. The frequency of the 4.43 MHz oscillator signal is controlled by a phase discriminator, receiving the burst of the chrominance signal to be recorded as reference. The crystal KT502 for the 4.43 MHz oscillator in U515E is outside the unit.

*Chrominance AGC voltage shaper*

Because, in the PAL-system, the phase of the burst signal is shifted +45° and -45°, line by line, a ripple voltage is present on the control voltage applied to the 4.43 MHz oscillator from the phase

discriminator in U515E.

The value of this ripple voltage is directly proportional to the burst amplitude of the chrominance signal applied to 5U515E. This ripple voltage is converted into a proportional DC-voltage by the colour AGC circuit and applied to the gain controlled amplifier in U514E.

*Colour killer*

If the AGC voltage becomes too small, the Schmitt-trigger in U515E, to which this control voltage is also applied, will change state, activating the two colour killers in U514E and there is no longer any chrominance signal present on the outputs 2 and 11 of U514E.

**1.4.13. 562.5 kHz processor U512E**

U512E supplies the following signals:

- On 4U512E, a 562.5 kHz oscillator signal
- On 5U512E, a  $F_H$  square-wave voltage (15.625 Hz)
- On 13U512E, a  $2F_H$  square wave voltage (2x15.625 Hz)
- On 7U512E, a key pulse for the burst gate in U515E.
- On 16U512E, a drive voltage for the luminance indicator circuit TS506, see also chapter 1.4.17.

*The 562.5 kHz oscillator signal*

As mentioned already, the 562.5 kHz oscillator signal is required for producing a 4.99 MHz oscillator signal in U515E. The 562.5 kHz oscillator functions as an astable multivibrator. A low-pass filter lets through only the first harmonics of the square wave because the mix in U515E can process only sine-wave signals. The 562.5 kHz oscillator is controlled by a phase discriminator in U513E, in which the line pulses of the luminance signal are compared with a signal, which is a result of the divide by 36 of the oscillator frequency. This signal is applied to the phase discriminator via 5U512E and 4U513E.

It follows that the oscillator will oscillate at exactly thirty six times the line frequency (i.e. 562.5 kHz).

*Key-pulse for the burst gate in U515E*

The burst gate in U515E will pass the burst signal only. The control pulse is produced in U512E, by adding the square-wave voltages on 5U512E (with a frequency  $F_H$ ) to the square-wave voltage on 13U512E (with a frequency  $2F_H$ ), in a certain manner. On the output 7U512E, a pulse with the required width and phase relation with respect to the burst signal, is available. This pulse is applied to the burst gate and to the colour AGC circuit, via 10U515E. Owing to variations in temperature, the phase relation between key pulse and burst signal may be changed. The burst gate in U515E will then be opened at the wrong moment. To avoid this, a drift compensator has been applied, contained in U513E. On one hand, the synchronization signal is applied to this drift compensator, on the other hand the  $2F_H$  pulse, via 11U513E. From these two signals a correction signal is derived, which is applied to the phase discriminator.

**1.4.14. Reference processor U513E**

U513E supplies the following signals:

- On 8U513E, the synchronization signal, separated from the luminance signal
- On 2U513E, the control voltage for the 562.5 kHz oscillator in U512E, as mentioned previously
- On 9U513E, a 50 Hz reference pulse for the servo systems
- On 1U513E, a pulse for suppressing the so-called sync-dot in the luminance signal, on playback.



#### *The sync separator*

The detected luminance signal is applied to the sync separator, via 6U513E. On 8U513E, only the sync signal (inverted) is present. The sync signal is applied to the following circuits:

Outside U513E

- To the luminance indication circuit in U512E
- To 2U511

Inside U513E

- As mentioned already, to the phase discriminator for the 562.5 kHz oscillator and to the corresponding drift compensator
- To the frame sync pulse separator

#### *50 Hz reference pulse generator for the servo systems*

The servo systems in recording and playback position require a stable 50 Hz reference pulse. Also, on recording, the frame pulse in the video signal must be modulated on the tape on a predetermined spot. To this purpose a pulse, derived from the frame pulse, is used as reference for the servo systems.

The 50 Hz reference pulse generator consists of an astable multivibrator which, on recording, is triggered by the frame pulse. The frame pulse, via an electronic switch, is applied to the generator. The electronic switch, in recording position, is kept in lowest position by the frame pulse identification circuit.

However, if in recording position for whatever reasons the frame pulses might drop off, the electronic switch automatically switches over. The reference generator is then triggered by a signal with the mains frequency.

#### *Pulse shaper for sync-dot suppression*

This circuit will be described in the playback section.

#### **1.4.15. Writing current amplifier on p.c. board 90**

As mentioned already, the luminance and chrominance signals to be modulated onto the tape are applied to 3U701. The amplitude of the FM signal on this point is 1 V<sub>pp</sub>.

The amplitude of the chrominance signal is 90 mV<sub>pp</sub> (for 75 % saturated colour bars).

This signal is applied to point 907 of the writing current amplifier via the plug connection F24.

The writing current amplifier TS901-TS903 supplies the writing current required for magnetizing the tape. The luminance writing current (25 mA) magnetizes the tape very strongly and, so, works linearizing for the chrominance signal.

The writing current amplifier, unlike in preceding VCRs, functions as a current source. The advantage being that the writing current is always constant and, so, independent of inductivity tolerances and changes of the video heads (the inductivity of the video heads decrease as they wear).

The signal is amplified by TS901. The amplification of this stage is determined by the resistors R903 and R906. By means of the transformer in the collector circuit the output transistors TS902 and TS903 are driven in antiphase. These two output transistors are operating in class A and, by means of R909, R907, C902, R910, R908, C903 in large negative feedback.

By driving the output transistors in this manner, the severe quality demands are satisfied.

The signal is applied to the video heads K1 and K2, via the rotating transformer S1, S2 which, in the recording position, is connected to the collectors of the output transistors.

#### **1.4.16. Audio gain controlled amplifier, U509**

U509 has the following functions:

- Preamplifier
- Recording amplifier
- Automatic modulation depth control
- Audio indication (driving)

The signal supplied by the sound detector U508, is applied to the preamplifier, via 13U509. External audio signals can be applied to the preamplifier via socket BU504. Between pins 1 and 4 a microphone can be connected, and between pins 3 and 5 an audio signal of 1 V rms can be applied. When a plug is inserted into BU504 switch SK504 opens and the audio detector in U508 is cut off. The controlled signal is available on the output of the recording amplifier 8U509. The audio signal for the UHF modulator is taken off via 17U509.

#### *Automatic modulation depth control*

The signal on 8U509 is also applied to a rectifying circuit. The DC-voltage obtained is applied to an NPN-transistor.

In the block diagram of U509, this transistor is schematically shown as a variable resistor. If the signal on the output should become too great, then the rectified voltage would also increase. The transistor will become more conductive, so that the collector-emitter resistance decreases. The signal on the input of the recording amplifier decreases and so the output voltage on 8U509. The time constant of the control circuit is 60 sec.

#### **1.4.17. Erase oscillator U510**

In position recording, U510 has the following functions:

- Erase oscillator
- Adding the premagnetization current

#### *Erase oscillator*

The erase oscillator frequency is approx. 60 kHz. The erase signal is applied to the erase head K5 via 7U510 and plug connection K21.

#### *Premagnetization current*

The premagnetization signal, as usual, is taken off the erase oscillator signal and, via a transformer, added to the audio signal. Next, this signal is applied to p.c. board 20, via 1U510, plug connection K16 and A53. On this p.c. board, the switches SK201 and SK202 are located, operated by the recording and start keys resp. In recording position, the contacts 13 and 12 of SK201 are interconnected, so that, via plug connection A46, the signal is applied to audio head K3. The other side of the audio head, via R540, is connected to earth. The junction of R540, with K3 is connected to 6BU504. This point is used as check point for the premagnetization current adjustment.

#### **1.4.18. Signal indication, p.c. board 30**

On p.c. board 30, 3 LEDs D301-D303 are located, lighting up when resp. luminance, chrominance or audio signals are present.

#### *Luminance indication*

As reference for the luminance indication, the synchronization signal is used.

As discussed already, the synchronization signal separated from the luminance signal, is available on 8U513E. This signal is applied to the luminance indication circuit, via 8U512E. This circuit will deliver a positive voltage only, if the synchronization signal supplied is sufficiently free from interferences.

The positive voltage is applied to the base of TS506, via 16U512E and resistor R556. TS506 becomes conductive, so that the cathode of LED D301 is connected to earth, via R557 and this transistor. From the +3 supply voltage, a current starts flowing through the diode, so that it lights up.

*Chrominance indication*

As reference for the chrominance indication, the chrominance AGC voltage, produced in U515E, is used. As described, the AGC-voltage is also applied to a Schmitt-trigger. When the chrominance signal is strong enough, output 9U515E is positive. This positive voltage is applied to the base of TS505, via R551. TS505 becomes conductive, so that also D302 becomes conductive, and lights up.

*Audio indication*

As reference for the audio indication, the audio signal, rectified in U509, is used. If a DC-voltage is available on the output of the rectifier, the electronic switch, which is connected to 11U509, is closed. The cathode of D303 is then connected to earth, so that the diode lights up. Because the time constant after the rectifier is relatively small (47 msec) at first, the DC voltage will decrease quickly when no further signal is supplied. The electronic switch is then opened and LED303 no longer lights up. In practice D303 lights up in the rhythm of the audio signal applied.

**1.5. DESCRIPTION OF THE CIRCUIT DIAGRAM OF THE SIGNAL SECTION IN PLAYBACK POSITION**

**1.5.1. Introduction**

In circuit diagram A, the main signal paths in the position playback are marked with a solid green line. As already mentioned in "Recording", the main signal paths on both recording and playback, are marked with a dotted violet/green line.

**1.5.2. Head amplifier, p.c. board 90**

In playback position, the signal induced in the video heads K1, K2 is applied to the input transformer, via the rotating transformer S1, S2. The input transformer adapts the impedance of the video head circuit to the input impedance of the first amplification stage, the field effect transistor TS904. The signal is further amplified by TS905 and TS906 and on the output point 905 has an amplitude of 70 mVeff. From this output, the signal is applied back to the gate of TS904 via feedback network C910, R922, R923, R918.

As a result, a frequency characteristic flat up to 5 MHz is obtained. The amplification of the head amplifier is abt. 700.

After the head amplifier, the signal is applied to the luminance and chrominance playback section, via plug connection F21.

**1.5.3. Luminance playback section**

*1.5.3.1. Introduction*

The specific luminance playback section is made up of the units U702E, U703, U704 and U721. Its function is to separate the chrominance signal from the luminance signal modulated in FM and, next, to demodulate it. Moreover, it must fill up drop-outs free from interference.

*1.5.3.2. FM-playback processor U702E*

U702E has the following main functions:

- Suppressing the chrominance signal
- Increasing the bandwidth for black-and-white signals
- FM gain controlled amplifier
- Drop-out detector

Suppressing the chrominance signal

The signal is applied to a high-pass filter in U702E via an electronic switch. On playback of a colour signal recorded on tape, the electronic switch will be in the position drawn. Next, the signal passes the absorption filters S706, C710 and S705, C709 adjusted to 562 kHz and 590 kHz resp. Consequently, the chrominance signals in the neighbourhood of the 562.5 kHz chrominance carrier are crushed, so that they cannot cause interference in the luminance channel. With R702, the high-pass filter is adjusted. The frequency characteristic in minimum and maximum position of R702 is shown in Fig. II-9. Adjusting R702 involves compromising.

On one hand, it is important that the FM sidebands in the range between 1 and 2 MHz are not suppressed too much, because the FM sidebands in this range are important for the resolution of the detected luminance signal. On the other hand, the amplitude of these FM sidebands may not become greater than that of the FM carrier proper. This is evident, when the playback frequency characteristic of the video heads is considered, Fig. II-10. The conclusion is that, proportionally, the FM carrier is reproduced with a much smaller amplitude than the FM side-bands in the range between 1 and 2 MHz. If the amplitude of the side-bands exceeds that of the carrier, the limiter in U703 gets stuck, so that information is lost. This symptom is recognizable in the picture in the shape of short, black horizontal strokes after a black-and-white changeover. Moreover, the high-pass filter suppresses the chrominance signal.

Increased bandwidth for black-and-white playback  
On playback of a black-and-white signal recorded, the electronic switch in U702E is automatically set to top position. The signal on 3U702E is then passed on. This signal is not subjected to the chrominance absorption filters S706, C710 and C709. As a result, the FM sidebands under 1 MHz are less suppressed, so that the resolution of the luminance signal is greater. The electronic switch in U702E is controlled by the colour killer signal.

FM gain controlled amplifier

In the subsequent gain controlled amplifier the FM signal is amplified in a manner that there is always an FM signal of constant amplitude available on the output of 15U702E. The control voltage for the gain controlled amplifier is produced by rectification of the FM signal. After the gain controlled amplifier, all signals with frequencies exceeding the playback frequency range of the video heads (approx. 5 MHz) are suppressed by the low-pass filter.

Drop-out detector

The function of the drop-out detector is to recognize a drop-out in the FM signal and derive a switching pulse. In its turn, this switching pulse actuates the drop-out compensator, so that the drop-out in the output signal is filled up. The drop-out detector is an envelope detector. The output



signal of the detector triggers a Schmitt-trigger controlling an electronic switch in U703 and U704. The sensitivity of the detector is factory adjusted.

1.5.3.3. FM demodulator U703 (main channel)

The FM signal is applied to 5U703. It is amplified and limited and, next, applied to an FM demodulator. The detected luminance signal is applied to an electronic switch via a low-pass filter (3 MHz). Normally, this switch will be in the position drawn, and the signal is applied to the output 1U703, via an amplifier in which also the video de-emphasis is effected.

1.5.3.4. FM demodulator U704 (drop-out channel)

The contents of U704 are practically the same as those of U703. The switching sequence, however, is different. The FM signal on the output 15U702E is also applied to the electronic switch in U704. Normally, this switch will be in the position drawn, passing on the FM signal. Via an amplifier, a 64  $\mu$ s delay-line and a limiter amplifier, the signal is also applied to an FM detector. The detected signal is applied to the other input of the electronic switch in U703, via a low-pass filter (3 MHz), in which the FM carrier remainders are suppressed. This signal is delayed by 64  $\mu$ s (exactly one line duration) with respect to the signal on the other input of the switch.

Drop-out compensation

If a drop-out occurs in the FM signal reproduced, it will be detected by the drop-out detector in U702E. The Schmitt-trigger delivers a signal, so that the electronic switches in U703 and U704 switch-over. Now, the electronic switch in U703 passes on the signal detected in U704. As already mentioned, this signal is delayed by one line duration. It follows that the drop-out is filled up by the information of the preceding line. As, in practice, the information of 2 subsequent lines is practically the same, the drop-out is filled up invisibly. Because also the electronic switch in U704 is switched-over, the FM signal, after limitation in U704, is redirected to the input of the unit. In this manner, in case of a long drop-out (longer than one line duration), the information of the last correct line is repeated again and again, so that also drop-outs longer than a line duration are filled up.

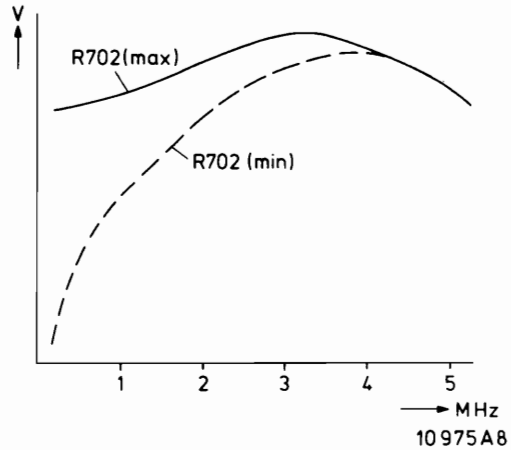

Fig. II-9

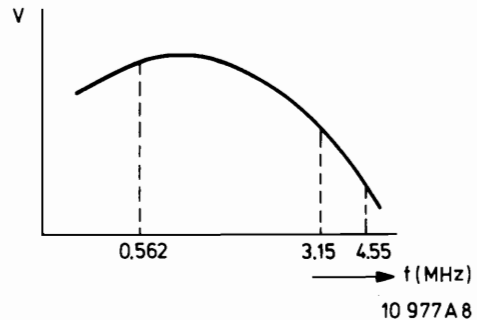

Fig. II-10

1.5.3.5. Crispening, U721

Principle

On account of the limited bandwidth of this recorder (3 MHz), a square-wave voltage recorded (Fig. II-11A), after playback, will be as shown in Fig. II-11B. The rise time has increased, resulting in a non-sharp transition on the TV screen. Crispening means adapting the signal in such a way that the steps in the signal reproduced, are artificially provided with a sharper edge. The adaptation of the signal is shown in steps in Fig. II-11.

The signal reproduced (B) is differentiated, resulting in signal (C). Signal (C) is differentiated again, resulting in signal (D). Signal (D) is inverted, resulting in signal (E). The signals (B) and (E) are added together, resulting in the signal required (F). When comparing the non-adapted signal (B) to the adapted signal (F), it shows that the rise time has decreased. The block diagram of U721 is shown in Fig. II-12.

Between the first and second differential stages, is a signal threshold switch, the result being that only large signal steps are selected for crispening.

By varying the amplitude of signal (E), see Fig. II-11, the crispening strength can be adjusted. Because the original signal in the right phase, there is a delay line in the signal path of the original signal. The signal is applied to 17U507 via the crispening unit and via plug connections F42 and L52. From this point onwards, the luminance signal reproduced follows the same signal path to the UHF modulator and to the aerial output as the signal on recording.

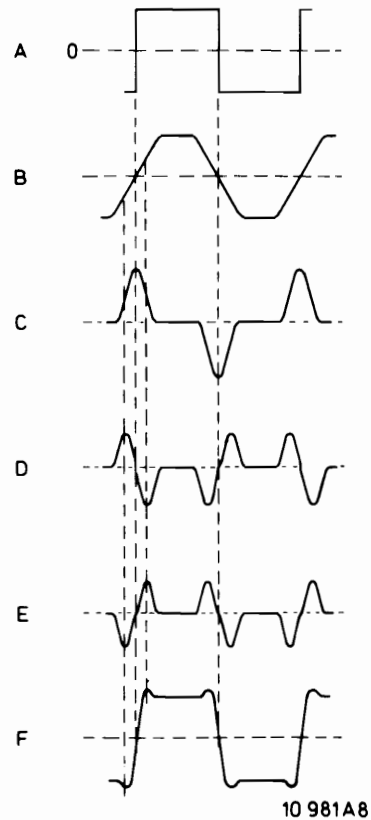

10 981A8

Fig. II-11

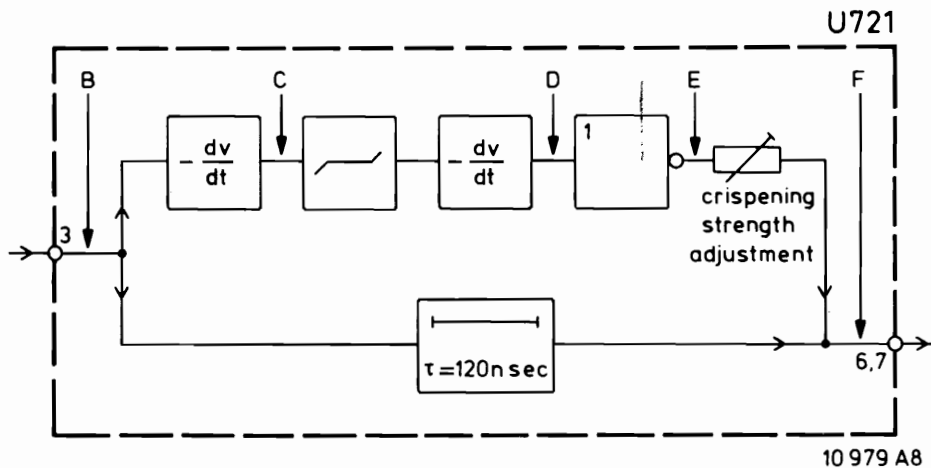

10 979 A8

Fig. II-12



#### 1.5.4. Chrominance playback section

##### 1.5.4.1. Introduction

The specific chrominance playback section is made up of low-pass filter S703, S704, C703-C707 and the transistors TS701 and TS702. The rest of the chrominance playback circuits are contained in the units U512E, U513E, U514E and U515E and, in playback position, most of them work in the same way as in recording position. The deviations only are discussed in this chapter.

##### 1.5.4.2. Low-pass filter S703, S704, C703-C707

The video head signal is applied to the chrominance playback section, via the plug connection F21 and C702. With low-pass filter S703, S704, C703-C707, the 562.5 chrominance signal is adequately separated from the remaining head signal. Next, the signal is applied to the gain controlled amplifier in U514E, via amplifier TS701, emitter-follower TS702, plug connections F33 and L33.

##### 1.5.4.3. Chrominance AGC + playback mixer, U514E

The gain controlled amplifier in U514E amplifies the 562,5 kHz chrominance signal of constant burst amplitude, which is then applied to the mixer. After mixing with the 4.99 MHz oscillator signal, also present on playback, the difference in mix product 4.99 MHz - 562.5 kHz is our original 4.43 MHz chrominance signal again. This signal is applied again to output 2U514E, via the 4.43 MHz (band)-pass filter and the colour killer circuit. From this point onwards, the chrominance signal follows the same path to the UHF-modulator as in recording position.

##### 1.5.4.4. 4.99 MHz processor + chroma AGC voltage former U515E

As mentioned above, an 4.99 MHz oscillator signal must be available on playback. This signal is obtained by applying a 4.43 MHz and a 562.5 kHz oscillator signal to the mixer in U514E. The sum mix product is the 4.99 MHz signal. Because the 4.43 MHz oscillator signal, which is applied to this mixer, may be seen as the new chrominance carrier, this oscillator signal must have great stability. In playback position, the 4.43 MHz oscillator signal, used on recording, does not have this stability and therefore cannot be used.

This is explained as follows:

The 4.43 MHz oscillator signal, used on recording, is also required in playback position for obtaining the AGC voltage for the gain controlled amplifier in U514E. This is because the phase-discriminator, the colour AGC and the 4.43 MHz oscillator are contained in one IC. Suppose the frequency of the 4.43 MHz signal in playback position tends to become higher. After mixing with the 562.5 kHz oscillator signal, the 4.99 MHz signal on 7U515E will become higher, likewise the carrier of the 4.43 MHz chrominance signal on 13U514E, obtained after mixing. The burst of this signal is applied as reference to the phase discriminator in U515E. The phase discriminator will deliver a control voltage to the 4.43 MHz oscillator, so that the frequency deviation becomes greater still. It follows that on playback an extra 4.43 MHz oscillator is required. This oscillator is made up of TS504 and crystal KT501. This oscillator signal is applied to the mixer in U515E, via 16U515E.

##### 1.5.4.5. 562.5 kHz processor U512E

In playback position, U512E works in the same way as on recording. The luminance indicator drive circuit, however, is switched off.

##### 1.5.4.6. Reference processor U513E

50 Hz reference generator

Because on playback, there is no supply voltage on 13U513E, the frame pulse identification circuit will not work. Consequently, the electronic switch is set to top position. As a result, the 50 Hz reference generator in playback position, is continuously triggered by a signal having the mains frequency.

Pulse former for sync dot suppression

As described already in chapter 1.2.1., the 25 Hz sync pulse is modulated across the video information on the tape (Fig. II-1). The position on the tape, where this pulse is modulated, corresponds with the position, where the frame blanking is modulated by the video heads. In playback position, this pulse is also read by the video heads. After the FM detector, this pulse will give an interference pulse in the frame blanking of the video signal. Normally, this interference pulse is not visible on the screen, because during this time frame flyback takes place and the picture tube is cut-off. In sets where this cut-off voltage is too small, however, the interference pulse may be visible on the screen as a white dot. In order to make the pulse invisible in these cases, a so-called sync dot suppression has been built-in.

The working:

During frame blanking (approx. 20 black written lines after the frame pulse), the luminance signal on junction R517, TD501 is connected to earth, via elco C509 and the electronic switch connected to 1U513E.

As a result, the interference pulse is suppressed. The control pulse for the electronic switch is derived from the frame pulse. The pulse duration is abt. 1 ms and is determined by a pulse shaper, the pulse comes after the frame pulse. The consequent interferences occurring also in the sync signal are of no importance, because in U511 a new sync signal is added.

**N.B.** In VCR's marked WD10/735 and up (applicable for N1512 only), in playback position a luminance signal is applied which is no longer influenced by the crispening unit U721.

At point 1 of U703, the luminance signal is applied to the sync separator in U513E, via R714, R715, F32, L32 and D518.

The + 6B supply voltage on panel 70 is now derived from the + 6A supply voltage.

D517, which is turned off during playback, provides that the luminance signal at point 17 of U507 cannot reach the sync separator.

### 1.5.5. Sound

On playback, the signal induced in the audio head is applied to the preamplifier in U510, via contacts 11 and 12 of SK201, the plug connections A56 and K13. Next, the signal is applied to the amplifier in U509, operative on playback, via a trimming potentiometer. The electronic switch in U510, after the start key has been pressed, opens after a certain delay (abt. 5 secs). This prevents a disturbing wow and flutter from being audible during the lock in time of the tape servo system. The audio signal for the UHF modulator is taken off again via 17U509. Because, in playback position, a supply voltage is present on 10U509, the electronic switch connected to this point is closed, so that the audio signal is also available on BU504 points 3 and 5. Because in playback position a supply voltage is fed to the preamplification stage in U509, the output is short-circuited to earth, via an electronic switch. In stop-motion position, this switch is also closed.

## 1.6. ADDITIONAL CIRCUITS FOR N1512

### 1.6.1. Introduction

The additional circuits and cable trees for the N1512 are marked with a yellow frame in diagram A. These circuits are located on p.c. board 80 only. This p.c. board is connected to p.c. board 50 with the plug connections R11-R16 and R31-R36 and to p.c. board 31 with R21-R22.

P.c. board 80 has the following sockets:

- BU801 - TV-socket (DIN, 6-pole, 240°)
- BU802 - CVBS output (BNC)
- BU803 - CVBS input (BNC)

### 1.6.2. Recording via the CVBS input BU803

If a recording is made via the CVBS input, the 8th channel selector push button must be pressed first. SK318a is then switched-over, so that a supply voltage is fed to the recording circuits on p.c. board 80, via plug connections R42 and R21 (+5c).

However, the RF section must be switched off. This is achieved, because solder bridge between connections 5 and 6 of p.c. board 31 of the N1512 set is open. When the 8th channel selector push button is pressed, there is no more supply voltage on point 6 of p.c. board 31, so that the supply voltages +5A and +5B disappear (see list of supply points on the right hand side of the diagram). Channel selector U553, a.o., is fed from this supply and, therefore, is switched off. Also the audio demodulator in U508 must be switched-off.

This is done as follows:

The +5A supply voltage is known to disappear, if the 8th channel selector push button is pressed. The cathode of D513, via the load, is connected to earth, so that the diode becomes conductive. As a result, the voltage on junction R503, R522 decreases. Also the voltage on 17U508 decreases, so that the FM demodulator circuit is switched-off. The CVBS signal to be recorded is applied to the gain controlled amplifier U822, via R804, amplified by U822 on constant sync pulse amplitude and clamped on black level. The clamping pulse is

derived from the line sync pulse, which is applied to 12U822 via the plug connections L23 and R33. Moreover, U822 has a built-in device taking care that the white level on output 17U822 does not exceed a given value. In U823, the CVBS signal is split up into a luminance and a chrominance signal. On output 11U823 only the luminance signal is still available, and is applied to 17U507, via plug connections R31 and L21. From this point onwards, the luminance signal follows the same path as the luminance signal during RF-recording. On point 17U823, only the chrominance signal is still present. Via plug connections R37 and L27 it is applied to the input of the gain controlled amplifier in U514E. From this point onwards, also the chrominance signal follows the same path as via RF-recording.

### 1.6.3. CVBS-output BU802

In switched-off position of the set, BU802 is passively interlooped with video input BU803, via the relay contacts of RE802. After switching on the set, RE802 is energized and BU802 is connected to the CVBS-output of U511, via contacts 5, 6 of RE802, transistor TS801 and plug connections R14 and L14.

It follows that always an actively interlooped signal is applied to the CVBS output BU802 as soon as the set is switched on.

### 1.6.4. TV-socket BU801

TV-socket BU801 may be used in combination with a TV-receiver equipped with a video adapter. The CVBS signal and the sound signal from the TV-receiver is applied to points 2 and 4 of this socket resp. In playback position, to the same points the CVBS signal reproduced and the sound signal from the VCR are applied resp. From the VCR, a supply voltage is fed to point 1 of the socket, automatically setting the TV-receiver to recording or playback position. The VCR delivers a supply voltage to point 5, providing the adapter in the TV with supply voltage.

#### *Recording via microphone*

The sound signal on point 4 of BU801, on recording, is applied to the diode input of 14U509, via the relay contacts in U823 and via plug connections R11 and L11.

If BU504 is plugged-in (e.g. a microphone), the +5 supply voltage to plug L24 drops off, so that the relay contact in U823 is released. Only the audio signal on BU504 is then applied to the recording amplifier in U509.

### 1.6.5. Monitoring via BU801

As already described, the CVBS-output BU802 is always connected to the CVBS output on unit U511, when the set is switched on. Point 2 of BU801 is connected to the CVBS output of U511 only in the playback and stop motion position because only then is relay RE801 energized. When recording via the tuner it is possible to monitor via 2BU801, by pressing the stop motion button, thereby feeding the +12 V supply to panel 80 and energising RE801, connecting the CVBS output of U511 to pin 2BU801.



## 2. THE SERVO SECTION (circuit diagram B)

### General

The circuitry of the servo section is mainly located on p.c. board 20. In the following description the units are shown as block diagrams.

### 2.1. THE HEAD SERVO

The head servo ensures that the head disc rotates at the correct speed and that the video heads are in a specific position relative to the tape during the frame pulses.

For this purpose a reference signal of constant frequency is required.

The signal which is applied to point A51 has a frequency of 50 Hz and, during recording, it is derived from the frame pulses of the signal to be recorded and during playback from a signal of the mains frequency.

As the head servo requires reference pulses with a frequency of 25 Hz, the 50 Hz reference signal is applied to a 1:2 divider which is a bistable multivibrator (flip-flop) inside U216.

The slope generator also inside U216 (which operates in accordance with the bootstrap principle) converts the squarewave 25 Hz signal available at B43 into a slope signal.

The permanent magnet which is mounted underneath the head disc induces a pulse in servo head K6 upon every revolution of the head disc. If the speed of the head disc is correct this pulse will be applied to point 17 of U216 with a repetition frequency of 25 Hz.

During the presence of this servo pulse the instantaneous value of the slope voltage is transferred to point 17 of U219.

The monostable multivibrator in the head servo section of U216 serves to derive a pulse of specific width from the pulse that has been induced in K6. The pulses at the output (pin 15 of U216) of this multivibrator are applied to the circuit which provides protection against blocking of the head disc on p.c. board 10) via A61 on panel 20. The reference pulse whose amplitude corresponds to the instantaneous value of the slope voltage at B41 is applied to the input of the storage circuit in U219. In this circuit a capacitor is charged to a voltage which corresponds to the peak value of the reference pulse.

The d.c. voltage across this capacitor, which is a measure of the point where the slope voltage is sampled by the servo pulse, is applied to one of the inputs of the operational amplifier. The other input of the operational amplifier receives a d.c. voltage which is adjustable with a potentiometer. If the two input voltages of the operational amplifier are equal, the phase of the head drum will be correct. In order to stabilize this operational amplifier and to ensure that it has a specific frequency response, feedback is provided in the form of both a positive and a negative feedback circuit. Both circuits are frequency dependent. This ensures that small deviations from the nominal phase of the head disc result in a substantial variation of the output voltage of the operational amplifier.

By means of the potentiometer at the other input of the operational amplifier the balance is adjusted, i.e. the voltage across the capacitor in the storage circuit for which the operational amplifier is balanced.

Since this voltage is defined by the point where the slope voltage is sampled by the servo pulse and since the magnet underneath the head disc has a fixed position relative to the video heads, this potentiometer in fact adjusts the location of the picture gap.

The output voltage of the operational amplifier is applied to the output stage. This output stage comprises TS201 and the transistor in U219 (see Fig. II-13).

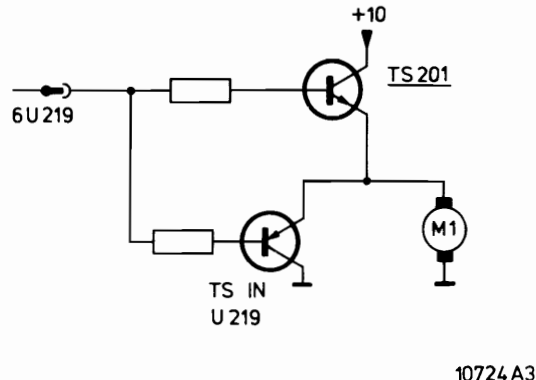

Fig. II-13

TS201 supplies the current for the head disc motor M1. As this motor is included in the emitter circuit of TS201 the voltage across the motor is proportional to the output voltage of the operational amplifier.

When the recorder is switched off, the back emf produced by the motor (M1) running on, is used to turn on the transistor in U219, so that a short circuit is applied across the motor braking it rapidly, thereby ensuring that the negative  $V_{be \max}$  of TS201 is not exceeded.

The interference suppression circuit on p.c. board 40 serves for suppressing interference voltages induced by the motors.

### 2.2. THE TAPE SERVO

The tape servo ensures that the tape transport is as constant as possible both during recording and during playback, and that during playback the recorded magnetic tracks are in a fixed position relative to the video heads, so that these heads scan the tracks in an optimum manner.

In order to realize this the servo pulses which are induced in servo head K7 by the three permanent magnets underneath the flywheel during recording, are applied to point 5 of U216 via the amplifier stage in U217 and contacts 8 and 9 of SK201 and contacts 8 and 9 of SK202. Via A32 the servo pulses at point 13 of U217 are applied to the circuit (on p.c. board 10) which provides protection against blocking of the flywheel.

During recording the synchronizing signal is also modulated on the tape. For this purpose the squarewave 25 Hz reference signal at point 10 of U216 is applied to an amplifier stage in U217.

In this amplifier the squarewave reference signal is first differentiated, so that high voltages are induced in the coil which is included in the collector circuit. Via point 17 of U217 and contacts 18 and 19 of SK201 the induced pulses are applied to sync head K4. During playback the sync pulses which are read from the tape by K4 are applied to amplifier stage TS203 via contacts 17 and 18 of SK201. The output signal of this amplifier stage, after being additionally amplified in U217, triggers the monostable multivibrator in U217. At the output of this multivibrator pulses appear whose width is adjustable with R1 (Tracking control). Via contacts 7 and 8 of SK201 and contacts 8 and 9 of SK202 these pulses are applied to point 5 of U216. As the negative-going edge of the output signal of the monostable opens the sample gate in U216, this means that the phase relation between the control pulse and the synchronizing signal which is read from the tape is adjustable with R1. In order to prevent the tape from being damaged the tape must be kept taut during threading. During the threading or unthreading procedure a positive voltage is applied to B13. As a result of this T204 and TS205 are turned on. A positive voltage of approx. 26 V is then applied to the base of the output transistor TS202 so that the speed of the tape transport motor increases. The hysteresis coupling then ensures that the tape remains taut. The other circuits of the tape servo are identical to those of the head servo. For these circuit descriptions reference is made to the description of the head servo.

**N.B. Effective from factory code WD08**, the threading-out procedure is as described above.

However, during threading-in and also in stop position in threaded-in condition, the +12 V is applied to point 409 via SK9 and SK10 (which are coupled with the fast winding keys) and start key SK202. The voltage drop across D203-D205-D206 and be TS202 is approx. 2,5 Volts, so that the motor voltage will be approx. 9,5 Volts, As a result, the pulling force of the motor is limited and tape looping prevented.

TS206 is conductive, so that the output of the operational amplifier is short-circuited. To ensure that the control circuit is not off-balanced too far, so that an unnecessarily long pull-in time might arise, point 13 of U220 is stabilised at approx. 7,5 Volts, employing D208 and D209. If tape transport is switched-on, the motor voltage will increase to approx. 14 Volts (normal operation).

The greater part of the resulting energy increase is required to increase the rpm of the motor. The starting jerk at the tape is not so strong now, so that the chance of damage to the tape is reduced.

To prevent looping when switching over from fast wind to froward, the minimum motor voltage is limited at + 9 V, using D201, D202, D205, D206 and b-e TS202.

**N.B. Effective from factory code WD09**, U220 has been replaced with U221.

The servo pulses, present at point 13 of U227 both on recording and playback, are applied to the speed discriminator in U221.

It is made up of two monostable multivibrators connected in series. The first one supplies the scanning pulse, the second one the reset pulse of a sawtooth generator operating according to the bootstrap principle. The capacitor after the switch is charged up to the instantaneous value of the sawtooth voltage (see Fig. II-13a). At nominal tape speed, this voltage will be approx. 6 V.

If, for instance, the tape speed becomes too high, then the servo pulses will arrive at the input at a higher frequency, so that the capacitor is charged up to a higher voltage (see Fig. II-13b). Because this voltage is applied to the minus input of an operational amplifier, the result will be that the tape transport motor is braked.

If the tape speed becomes too low, the capacitor will be discharged, so that the speed of the tape transport motor increases. The buffer stage after the capacitor ensures that the capacitor is not loaded.

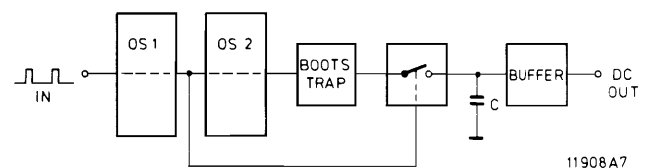

Fig. II-13a

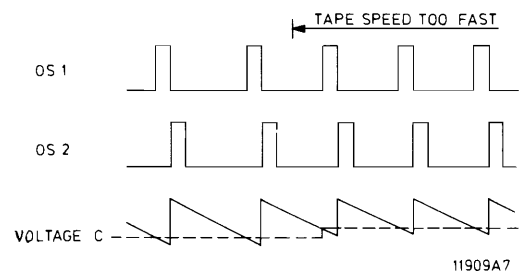

Fig. II-13b



### 2.3 THE DIGITAL LOCK-IN CIRCUIT (U218)

The digital lock-in circuit ensures that after the VCR has been switched on the head servo and the tape servo lock-in as soon as possible.

For this purpose the 25 Hz reference signal from U216 is compared with the frequency of the pulses from the head servo and the tape servo.

As the lock-in circuit for the head servo is identical to the tape servo, only the lock-in circuit for the head servo is described.

In the locked-in condition the reference pulse which is produced by the monostable in U218 is always followed by the sampling pulse which is applied to point 17 of U218.

Flip-flop 1 (see Fig. II-14) is then always set by the

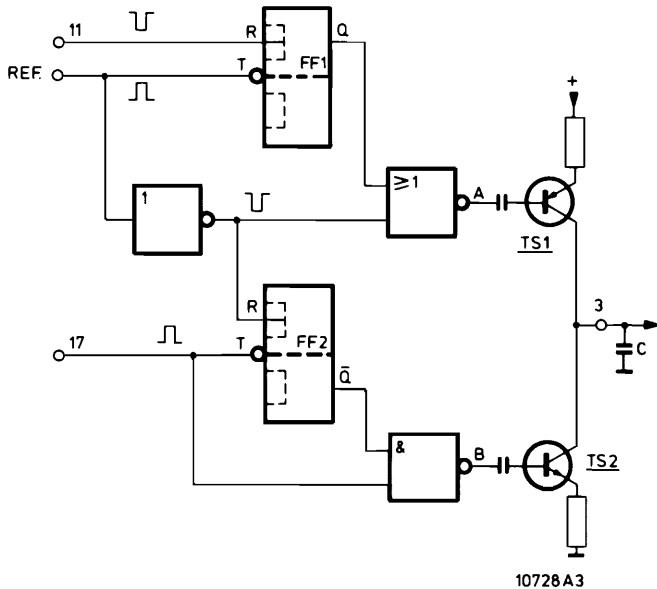

Fig. II-14

reference pulse and reset by the sampling pulse, whilst flip-flop 2 is set by the sampling pulse and reset by the inverted reference pulse, so that a squarewave signal with a frequency of 25 Hz will appear at the output of these flip-flops. As the inverted reference pulses and the signal at the Q-output of flip-flop 1 are supplied to the nor-gate the output signal of this gate will always be "0".

The sampling pulses and the signal at the Q-output of flip-flop 2 are supplied to the and-gate, so that the output signal of this gate will always be "1".

As a result, the output of the lock-in circuit (point 3 of U218) will not change.

If the speed of the head disc is for example too low, the reference pulses will not always be followed by a sampling pulse, but at certain instants 2 reference pulses will appear between 2 sampling pulses (see Fig. II-15). Flip-flop 1 then cannot be reset by the sampling pulse because it is already in the "0" state, so that the voltage waveform appears at the Q-output (see Fig. II-15).

This voltage and the inverted reference pulse are applied to the nor-gate, so that a pulse appears at the output of this gate (point A) each time that 2 reference pulses appear between 2 sampling pulses (viewed in time). The

negative-going edge of this pulse which is applied to the base of TS1 via a capacitor turns on transistor TS1, so that capacitor C in U219 is charged to a higher voltage. This voltage is applied to the operational amplifier, so that the speed of the head disc motor increases.

When the speed of the head disc is too high, 2 sampling pulses will appear between 2 reference pulses at certain instants.

Flip-flop 2 then cannot be reset by the reference pulse, because this flip-flop is then already in the "0" state, so that a voltage waveform as outlined in Fig. II-16 appears at the Q-output.

This voltage waveform and the sampling pulse are applied to a and-gate, so that a pulse appears at the output of this gate (point B) whenever 2 sampling pulses appear between reference pulses. The positive-going edge of this output pulse, which is applied to the base of TS2 via a capacitor, will turn on this transistor TS2, so that capacitor C is discharged. The discharge voltage is applied to the operational amplifier so that the speed of the head drum motor is reduced.

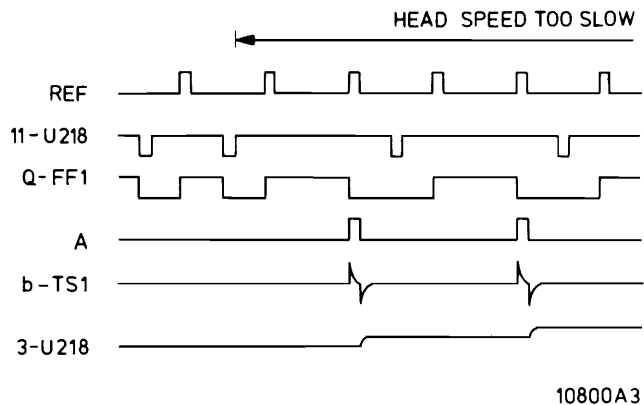

Fig. II-15

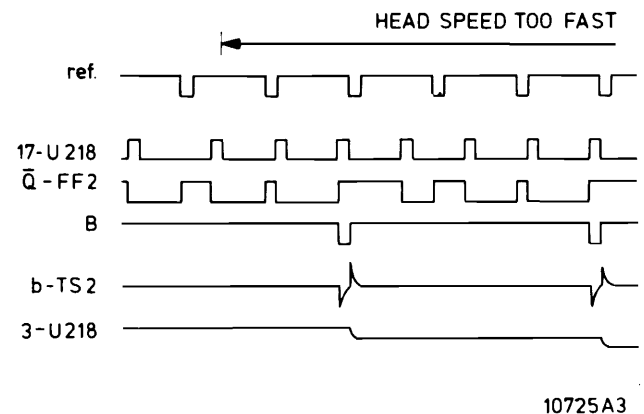

Fig. II-16

### 3. THE POWER SUPPLY AND PROTECTION CIRCUITRY (circuit diagram C)

#### 3.1. THE POWER SUPPLY SECTION

The VCR can be adapted to most mains voltages by changing the connections on the mains transformer. For this, see Chapter III, section 1.4.1.

The mains transformer is protected by the thermal fuse VL1. From the voltages across the 4 isolated secondary windings 6 supply voltages are derived on p.c. board 10.

As the aerial amplifier and the digital clock should also operate when the VCR is switched off, the +1 supply voltage is always available when the VCR is connected to the mains. The other supply voltages are switched on and off by means of a relay. From the bridge rectifier D102 across windings 8, 7 and 16,15 the +1 supply is derived being stabilised by the circuit TS1 and TS101 - 105 inclusive.

The auxiliary voltage for this stabilizer is obtained by rectification of the alternating voltage across windings 19, 20 and 11, 12 of the mains transformer by means of the diodes D104 and D105.

This supply voltage (+11) is also used for the button release solenoids S5 and S6.

From the bridge rectifier D101 across windings 17,18 and 9,10 the +10 supply voltage is derived, and is used for the head disc and tape transport motors. From the bridge rectifier D103 across windings 19,20 and 11,12 the +7 supply voltage is derived being stabilised by the circuit TS106-TS107 and TS123-TS125 inclusive.

The alternating voltage across windings 21,22 and 13,14 is used as 50 Hz reference signal for the digital clock.

This alternating voltage is also rectified by diode D108. The constant current source provided by TS108 serves to protect the TAA550, which stabilises the tuning voltage for the tuner, against overloading. The voltage across C110 is approx.55V. Load variations cause a current variation in R123, so that the voltage across this resistor also varies. As the voltage across diodes D109 and D110 is constant, the voltage at the base of TS108 will also vary. As a result of this the collector current of TS108 remains constant.

Via C108 and R122 a 50 Hz reference signal is applied to the reference oscillator U513 on p.c. board 50.

The -9 supply voltage is provided by diode D107 and is used for the automatic tuning on p.c. board 50. Resistor R162 serves to limit the current through zener diode D516.

#### 3.2. THE STABILIZERS

As the two stabilizers are largely identical only the stabilizer for the +1 supply voltage will be described.

The transistors TS104 and TS105 have a common emitter resistor. The base voltage of TS104 is determined by the zener diode D106.

As a result of this the base voltage of TS104 is highly constant and is substantially independent of the mains voltage. Voltage divider R113, R114 and R111,R112 determines the base voltage of TS105. Thus, voltage variations of the +1 supply voltage are partly transferred to the base of TS105. Assume that the +1 supply voltage tends to increase. A part of this increase then reaches the base of TS105. The collector current then increases, so that the emitter voltage also increases and the collector voltage decreases.

Since the base voltage of TS104 is constant, an increasing emitter voltage results in a decreasing collector current so that the collector voltage increases.

The decreasing collector voltage of TS105 cause a decrease of the current through TS102, whilst the current through TS103 also decreases because the collector voltage of TS104 increases.

Via emitter follower TS101 this voltage decrease reaches the base of TS1, causing this transistor to become less conductive, so that the assumed increase of the +1 supply voltage is compensated for.

The collector resistor of TS101 is connected to a higher supply (+10) so as, to extend the control range of TS1 (to a maximum of 0,3 Vce).

For reasons of stability metal-film resistors are used for the resistors R111 and R114.

The +1 voltage is adjusted by selection of the resistors R112 and R113. For this, see Chapter III, 1.4.2.

#### 3.3. THE CONTROL AND PROTECTION SECTIONS

##### General

Automatic switch off of the VCR is effected by means of the button release solenoids S5 and S6. When the coils are energized, their armatures release the "On" button, the tape transport keys and the recording key. The solenoids are included in the collector circuit of TS116 and TS114 respectively TS116, together with TS115 form a monostable multivibrator, whilst an other monostable is formed by TS113 and TS114.

These circuits serve to energize S5 and S6 for approx. 3 secs. if only a pulse-shaped control signal is available.

Diodes D122 and D123 protect transistors TS114 and TS116 against voltages induced in S5 and S6 when the current through the transistors is interrupted.

For the description of the following points reference is also made to the Survey of supply points on page 12 of Chapter IV.

##### 3.3.1. Switching on

The VCR is switched on when the On button (SK3) is depressed or when the digital timer turns on TS321 whilst the start button is depressed. In both cases point P23 is connected to chassis, so that RE101 is energized. If the cassette lift switch SK11 is now closed point 1 of the threading motor is connected to the +1 supply via contacts 1 and 2 of SK13 and contacts 5 and 6 of RE101. Point 2 of the threading motor is connected to chassis via contacts 2 and 3 of RE101.

As a result, threading begins.

Simultaneously relay RE102 is connected to the +1 supply via D132, and point P22 via D114. Consequently, all the other supply voltages are switched on, the motors M1 and M2 are started, and via point P22 the tape-transport motor receives the full operating voltage.

After bracket 281 has been rotated a few degrees SK12 is switched over and when the lower drum section has been threaded completely SK13 changes over. Via contacts 5 and 6 of RE101 and contacts 1 and 4 of SK13 point 1 of the threading motor is now connected to chassis, so that this motor is short-circuited and braked rapidly.

RE102 is now connected to the +1 supply via D115, so that the VCR remains switched on.



### 3.3.2. Switching off

The VCR is switched off when the Off button is depressed or when the digital timer cuts off TS321 whilst the start button is depressed. In both cases the chassis connection to point P23 is interrupted, so that RE101 is de-energized.

The cassette lift switch SK11 is still closed. As a result, point 2 of the threading motor is connected to the +1 supply via contacts 1 and 2 of RE101, contacts 1 and 2 of SK14, and contacts 1 and 4 of SK12. Point 1 of the threading motor is now connected to chassis via contacts 4 and 5 of RE101. Consequently, unthreading begins.

Via D133 point P22 is now connected to the +1 supply voltage, so that the tape transport motor receives the full operating voltage keeping the tape under tension during unthreading.

Via contacts 10 and 11 of RE101 a positive voltage is applied to the two monostable multivibrators, so that all the buttons which are depressed are released by the two button-release solenoids S5 and S6.

After bracket 281 has been rotated a few degrees, SK13 is released and when the lower drum section is fully threaded out, SK12 changes over again. This results in RE102 being released because the +1 supply is then disconnected, so that all the supply voltages are then switched off.

Point 2 of the threading motor is now connected to chassis via contacts 1 and 2 of RE101, contacts 1 and 2 of SK14 and contacts 1 and 2 of SK12, so that this motor is short-circuited and is braked rapidly. It must not be possible to unthread the tape during fast wind or rewind. To prevent this, SK14 is coupled to the fast-wind buttons and is operated if one of these buttons is pressed.

Unthreading by motor M3 is then impossible.

### 3.3.3. Blocking of tape transport during stop-motion

In order to prevent tape transport in the stop-motion mode, the lower reel disc is then blocked by RE1 (S3).

To obtain a still picture the stop button must be depressed after the stop-motion button has been depressed.

Contacts 4 and 5 of SK202 are then interconnected and the +1A supply voltage is then applied to the emitter of TS121 via D131.

If none of the two fast wind buttons is depressed, the base of TS121 is connected to chassis via R163, so that this transistor is turned on and S3 is energized. If now one of the fast wind buttons is depressed, contacts 1 and 4 of SK14 are interrupted and the +1 supply voltage is applied to the base of TS121 via D134, so that TS121 is turned off. S3 is then no longer energized and the lower reel disc is then unblocked. D124 protects TS121 against voltages which are induced in S3 when the current through TS121 is interrupted.

### 3.3.4. Automatic stop of the tape transport

For automatically stopping the tape transport at the end of the tape and at the beginning of the tape on rewinding, the tape is provided with strips of switching foil at both ends. These strips are fixed to the non-magnetized side of the tape.

In the fast wind mode contacts 1 and 4 of SK14 are closed, so that a positive voltage is applied to the base of TS119 via D119 and R142. TS119 is turned on and its collector voltage becomes low so that TS120 is turned off.

Consequently, the collector voltage of TS120 increases and the voltage on the tape contact of SK16 is then approx. 40 V.

When the contacts of SK16 are closed by the switching foil a negative-going pulse is produced at the collector of TS120, which pulse is applied to the base of TS113 via C121, as a result of which the depressed tape transport button is released. Finally, the VCR is switched off by the delay circuit TS111 after approx. 2 mins.

### 3.3.5. Suppressing the stop pulse of the tape transport

If a tape has been rewound completely the switching foil will generally be located beyond the tape contact. If in this situation the start button is depressed, the tape transport will be switched off again. In order to prevent this in the case of starting by means of the electronic timer, the tape transport stop pulse must be suppressed. This is achieved by the circuit with TS117 and TS118.

In position stop junction R140, R141 is connected to chassis via D118 and contacts 1 and 2 of SK202, so that C118 is short-circuited. When the start button is now depressed, contacts 2 and 3 of SK202 are interconnected and D118 is cut off, so that C118 is charged via R140.

At the instant that the VCR is switched on by means of the electronic timer (the start button is then already depressed and contacts 2 and 3 of SK202 are already interconnected) RE102 is energized and the +1A supply voltage is available. C118 is then also charged via R140. After 30-60 secs. C118 is charged so far that the voltage at the gate of TS117 has increased so far that this FET is turned on. As a result of this the source voltage decreases, so that TS118 is also turned on. A positive voltage from the divider R146, R147 is also applied to the base of TS119, so that this transistor is turned on. It is not until then that a pulse from the tape contact can energize the monostable multivibrator TS113, TS114.

### 3.3.6. Protection against tape damage

When the tape has been threaded and no tape transport takes place, the video heads will run on the same track upon every revolution of the head disc. This may lead to local wear of the tape.

In order to prevent such damage a protection circuit has been incorporated.

This protection circuit turns off the VCR if none of the tape transport buttons has been actuated approx. 90-140 secs. after the VCR has been switched on. The turn-off delay of approx. 90-140 secs. is obtained by means of TS111.

When the VCR is switched on the +1A supply voltage is available. C113 is then charged via R131. After 90-140 secs. C113 is charged so far that the voltage at the gate of TS111 has increased so far that this FET is turned on.

The voltage at the source then decreases, so that TS112 is also turned on. As a result of this a positive voltage is applied to the base of TS114 and TS116 via D121 and resistors R151 and R157, so that the VCR is switched off.

However, if within 90-140 secs. after the VCR has been switched on one of the fast wind buttons is depressed, SK14 which is mechanically coupled to these buttons is closed, so that a positive voltage is applied to the base of TS110 via D117 and R138. When the start button is depressed a positive voltage is also applied to the base of TS110 via P91 and R139.

As a result, TS110 is turned on and C113 cannot be charged so that the VCR cannot be switched off by the 2 min delay circuit.

### 3.3.7. Protection against blocking of the capstan and head disc

The VCR is protected against damage to the tape and motors which might arise should the head disc or capstan become blocked.

From the head servo circuit negative-going 25 Hz pulses are applied to P21. These negative-going pulses discharge C128 via D111 and R126. R128 and R129 bias TS109 so that this transistor is cut off.

When the head disc is blocked the pulses no longer appear at P21, so that after 2 to 3 secs. the voltage across C128 will have increased so far that TS109 is turned on via D128. As a result of this, the collector voltage of TS109 decreases, so that TS112 is turned on.

Via D121 a positive voltage is applied to the two monostable multivibrators, so that the VCR is switched off.

From the tape servo negative-going 25 Hz pulses are applied to P42.

As these pulses are supplied by a circuit with a high-ohmic output, TS126 has been included.

The positive-going edges of the signal at P42 turn on TS126, so that C131 is discharged.

Should the capstan become blocked, the 25 Hz pulses will no longer be applied to P42, so that after 8 to 15 secs. the voltage across C131 will have increased so far that TS109 is turned on via D130. This also results in the VCR being switched off.

### 3.3.8. Switching off of the VCR in the event of a mains voltage failure

This protection facility is necessary to prevent the VCR from being started when the mains voltage is restored whilst the tape is threaded around the head disc.

This may give rise to tearing of the tape and damage to the head disc.

When the mains voltage fails, the various supply voltages also cut out. However, the speed with which these voltages disappear depends on the magnitude of the load to which they are connected and on the capacitance of the capacitors which are included in the circuit.

C116 is charged to the +1A supply voltage. When the +1A supply voltage decreases, D120 will be cut off, so that C116 retains its charge.

As TS111 is turned on when the +1A voltage disappears, the base of TS112 will be connected to chassis via R133, so that transistor TS112 is turned on. The positive voltage across C116 is now transferred to the two monostable multivibrators via D121. As the voltage across C102 leaks away very slowly the two solenoids S5 and S6 are now energized, so that the On button and all buttons which are depressed are released.

However, the tape remains threaded, and is not unthreaded until the mains voltage is restored. If during a mains voltage failure, whilst the tape is threaded, the start button or one of the fast wind buttons is depressed, these buttons will be released when the mains voltage is restored.

When the mains voltage has returned the +1 supply voltage is applied to junction R137, C117 via contacts 1 and 4 of SK12 which are then closed.

As C117 is then still discharged, this positive voltage is applied to the two monostables, so that the two solenoids S5 and S6 are energized and all the push-buttons are released.

If a mains voltage failure occurs before the VCR is to be switched on by the electronic timer, the buttons which are then depressed are not released. This is because the VCR was not yet switched on and C116 cannot yet be charged.

As the tape has not yet been threaded either (contacts 1 and 2 of SK12 are still closed), C117 is charged slowly via R137 when the mains voltage is restored, so that the two monostables cannot be triggered. As a result of this, the start button and the recording button which are depressed are then not released.



#### 4. THE ELECTRONIC TIMER (circuit diagram D)

By means of the electronic timer the VCR can be switched on and off at preset times. The starting time can be preset max. 3 days in advance.

##### 4.1. DISPLAY

The time, starting time, period-time, and day are displayed by means of four 7-segment LED's D322 through D325. These LED's are driven directly by IC321. R355 and R356 serve to limit the current for IC321 (the current through these resistors is 5 mA per segment). IC321 supplies the current for the LED's and comprises the complete timer logic.

##### 4.2. THE 50/60 Hz OSCILLATOR

This oscillator is constituted by the free-running multivibrator TS326, TS327. D327 enables a 12 Vp-p signal to appear at the count input of IC321. When mains voltage is available this oscillator is controlled by a signal of mains frequency which is applied to the base of TS327 via R345, C323 and R346. C324 serves to eliminate HF interference on this signal. During a mains voltage failure the free-running frequency is mainly determined by the resistors R348, R349 and R350 and the capacitors C325 and C326, thus enabling the free-running frequency to be adjusted to 50 or 60 Hz with R350. In order to render the free-running frequency less dependent on the battery voltage, the multivibrator is supplied with the +B supply voltage. This voltage is stabilized by D333.

##### 4.3. CONTROL PUSH-BUTTONS

Upon depression each of the 6 push-buttons SK321 through SK326 connects the relevant input of IC321 to the +12 supply voltage. If none of the buttons is depressed these inputs are held at potential C by the incorporated resistors. In order to avoid erroneous operation of the timer in position "activate" in the event of a mains voltage failure, TS331 has been included. When the +A supply voltage decreases below approx. +10 V, the base voltage of TS331 will have decreased so far that transistor TS331 is cut off. As a result of this, the common point of the push-buttons is connected to potential C via R339, so that depression of the push-button does not result in a change of the potential at the relevant input of IC321. D326 ensures that a well-defined turn off voltage of approx. +10 V is obtained. As input 31 (fast set) of IC321 is not protected against bounce C327 has been added. In order to minimize the capacitance of C327 diode D334 has been included. C327 now cannot discharge via R341, R358 and TS322. R341 limits the current surge which occurs when SK322 is depressed, because C327 is then charged.

##### 4.4. RESET CIRCUIT

When the timer is switched on LED's D322 through D325 will be set to 12.00 and will start to flash with a frequency of 2 Hz. In the non-activated condition this flashing is a warning signal that there has been a mains voltage

failure and that the timer must therefore be reset. To reset the timer points 29 and 31 of IC321 must be connected to +12 V. TS322 simplifies the operation, by enabling the timer to be reset by merely depressing one of the buttons SK321 or SK322.

When the LED's D322 to D325 inclusive do not light up, the cathode voltage of these LED's is 0 V. The base voltage of TS322 is then also 0 V, so that this transistor is cut off.

The two set inputs (points 29 and 31 of IC321) R358, so that when one of the set buttons is depressed the LED's will stop flashing. The base voltage of TS322 then remains positive, so that this transistor remains conductive. In order to prevent TS322 from being turned off when the cathode currents of the LED's D322 to D325 inclusive are small (for example when displaying day 1) diodes D335 and D336 have been added, so that the base voltage of TS322 remains more positive than the emitter voltage.

##### 4.5. TIME DELAY

This time delay has been provided in order to prevent the time of the day being detuned inadvertently when the starting time, the period-time or the day is set.

This detuning occurs when one of the display buttons SK323, SK324 or SK325 is released before the set button SK321 or SK322. This is prevented in that TS332 remains cut off for approx. 2 secs. after one of the display buttons is released.

When one of the display buttons is depressed a positive voltage is applied to the base of TS330 via R359, R360 or R361, so that TS330 is turned on. As a result of this TS333 is also turned on and via voltage divider R364, R352 and R362 the base voltage of TS325 is reduced so far that this transistor is also turned on.

The battery load resistor R327 is now connected in parallel with the battery (also see Battery check). Normally, the base of TS332 is connected to C-potential via R328, so that TS332 is conductive. After one of the display buttons is depressed and is released again TS330 and TS333 are cut off, so that the collector of TS333 "opens" (see Fig. II-17 in which the transistors TS330 and TS333 are represented by a switch).

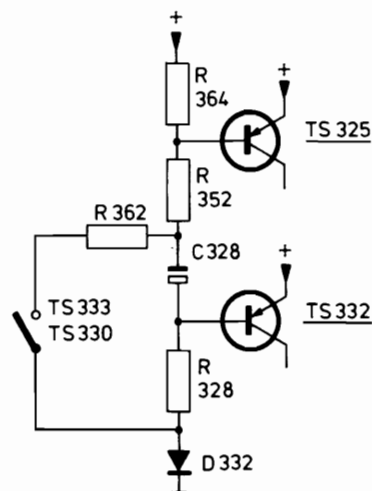

10799A3

Fig. II-17

The base voltage of TS332 now consists of the supply voltage and the voltage across electrolytic capacitor C328 and is more positive than the emitter voltage of TS332, so that TS332 is cut off. After approx. 2 secs. capacitor C328 will have discharged via R328 that the base voltage of TS332 has decreased to such an extent that TS332 is turned on again, thus enabling the set buttons to be actuated again.

After the display buttons have been released, the base voltage of TS325 will remain lower than the emitter voltage whilst electrolytic capacitor C328 has not yet been discharged.

After approx. 2 secs. the emitter voltage of TS325 will have increased so far that this transistor is turned off again and the battery load resistor R327 is switched out.

#### 4.6. ACTIVATE

By depressing button SK326 the timer is activated and the VCR will be switched on when the day indication is 0 and the preset time corresponds to the time of the day. In the activated condition the voltage at point 25 of IC321 is approx. 10 V. TS323, which is connected as an emitter follower, will consequently be turned on, and D321 will light up.

The current through D321 is then approx. 8 mA and is determined by R322.

#### 4.7. MAINS/BATTERY CHANGE-OVER

The free-running multivibrator TS326, TS327 and the logic in IC321 are battery-powered only in the activated condition during a mains voltage failure. The LED's D322 through D325 then do not light up. In the activated condition a part of the positive voltage at point 25 of IC321 is applied to the base of TS324 via D328 and voltage divider R325, R326, so that TS324 is turned on. During a mains voltage failure (+A is then 0 V) point 21 of IC321 will be connected to the negative pole of the battery via D329 and TS324 (see Fig. II-18).

In order to prevent D321 lighting up if the battery connections are inadvertently short-circuited, D328 has been included. D329 and R323 prevent the Vce max. of TS324 being exceeded when the battery connections are short-circuited.

When the timer is not activated the battery is at no load during a mains voltage failure (I battery < 1  $\mu$ A). The battery may be replaced by a Ni-Cd accumulator of the same size

This accumulator is then always re-charged with approx. 0,5-1 mA via D331 and R330.

#### 4.8. BATTERY CHECK

The decimal point in LED D324 will light up only if the battery load resistor R327 is in circuit (see Time delay) and the battery voltage is lower than approx. 6,7 V.

According as the battery voltage decreases the voltage at junction R330, R331 will increase.

As the emitter of TS328 is at a potential of approx. 4 V via voltage divider R332, R357 this transistor will be turned on if the voltage at the base has increased to approx. 4.7 V (see Fig. II-19). As a result of this TS329 is also turned on and the decimal point in D324 lights up.

This is possible only when the battery load resistor is included in the circuit.

#### 4.9. SWITCHING OUTPUT

When the timer is activated and the time of the day corresponds to the starting time whilst the day is 0, point 26 of IC321 is connected to the supply voltage for the preset period by IC321. The base voltage of TS321 then becomes positive, so that this transistor is turned on and point D11 is connected to earth, thus enabling the VCR to be switched on. The maximum switching current for TS321 is 100 mA and the maximum switching voltage is approx. +30 V.

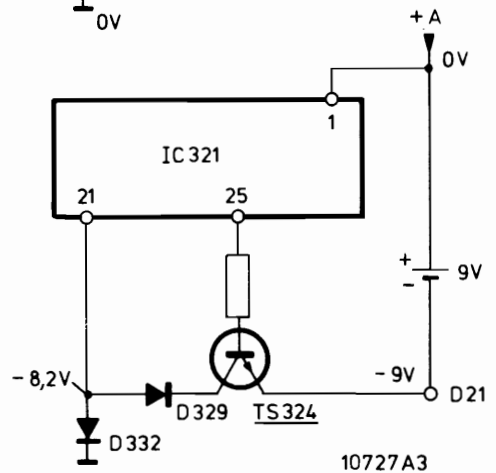
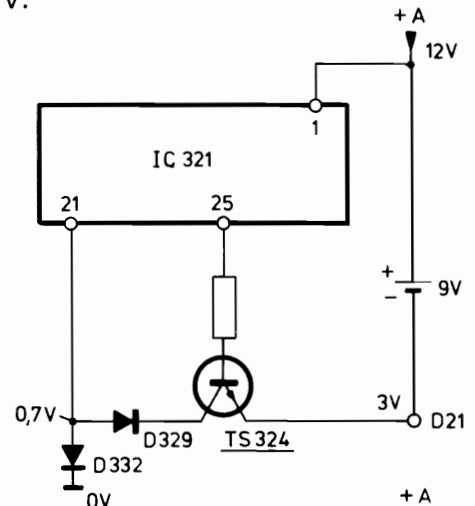
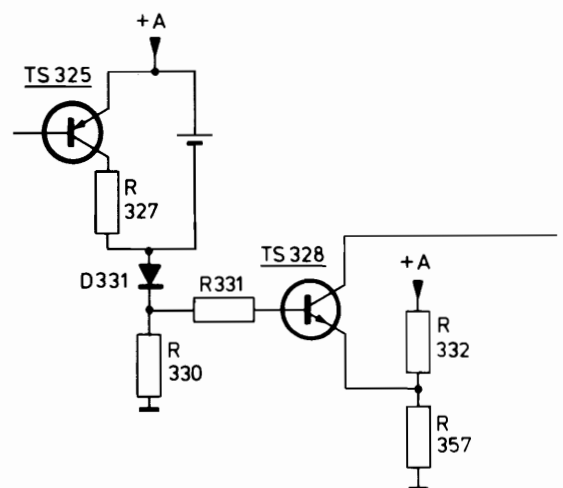

Fig. II-18



10726A3

Fig. II-19

#### 4.10. TIMER FEATURES

The timer is suited for 24-hour display, for 50 Hz drive and for a max. period time of 1 hour and 30 minutes. However, by fitting and/or re-arranging some jumper wires the timer can be adapted to 12-hour display, 60 Hz drive, and a max. time-period of 1 or 2 hours.

● *12 hour display*

By fitting a jumper wire between point 22 of IC321 and power supply point +A the display format is adjusted to 12 hours. The timer then runs from 0100 to 1259.

Point e of D322 must then be connected to point 19 of IC321 instead of point 18 via a jumper and the jumper between point g of D322 and point 19 of IC321 must be removed.

Segment e of D322 then gives the indication p.m. (post meridiem, which means in the afternoon) and segment f gives the indication a.m. (ante meridiem, which means before noon).

At midnight when the display goes from 1159 to 1200, the indication changes from p.m. to a.m. and at noon when the display goes from 1159 to 1200 the indication changes from a.m. to p.m.

● *60 Hz*

By including a jumper between point 30 of IC321 and potential point C, IC321 is adapted to a drive signal with a frequency of 60 Hz.

The input signal at point D13 should then also have a frequency of 60 Hz and the free-running frequency of the free-running multivibrator TS326, TS327 should then be adjusted to 60 Hz with R350.

● *Maximum time-period*

By removing the jumper between point 23 of IC321 and potential point C the timer is adapted to a maximum time period of 1 hour. By including a jumper between point 23 of IC321 and power supply point +A after removing the jumper between point 23 of IC321 and potential point C the timer is adapted to a maximum time-period of 2 hours.



**III. SERVICE ADJUSTMENTS AND LUBRICATING INSTRUCTIONS**

	<b>Page</b>	<b>Date</b>
<b>1. Electrical adjustments</b>		
1.1. Signal section (circuit units not included)	III-3	76-09-20
1.2. Signal section (circuit units)	III-5	-
1.3. Servo system	III-9	-
1.4. Supply voltages	III-10	-
1.5. Electronic timer	III-10	-
<b>2. Mechanical adjustments and checks</b>		
2.1. Tape deck	III-11	-
2.2. Switches	III-13	-
2.3. Lace-up	III-13	-
<b>3. Lubricating instructions</b>	III-17	-

## 1. ELECTRICAL ADJUSTMENTS

### 1.1. Signal section (circuit units not included)

#### 1.1.1. R507 (varicap voltage)

- Connect a voltmeter (position d.c.) to 2U553.
- Adjust with one of the tuning controls on the drawer U20 for a maximum voltage on 2U553.
- Drawer fully opened.
- Adjust with R507 the voltage on 2U553 to 28 V.

**Remark:**

During production, R507 has been deleted.

#### 1.1.2. R702 (high-pass filter)

● Method 1

- Record the test pattern VCR (bl/w) produced by PM 5509.
- Playback the recording.
- Adjust R702 so that the definition lines in the fifth bar from the top (about 3 MHz) are clearly visible.

● Method 2

- Record an off-air test pattern with definition lines.
- Playback the recording.
- Adjust R702 so that the 3 MHz definition lines are just visible.

#### 1.1.3. R710 (Adjusting the chrominance writing current)

- Tune recorder to colour bar pattern produced by a pattern generator.
- Recorder in position RECORDING with inserted cassette.
- Connect oscillograph to 3U701 (checking plug F13).
- Switch off FM modulator by connecting 17U701 to mass.
- Adjust with R710 the amplitude of the chroma signal for 90 mV<sub>pp</sub>.
- Remove short-circuit of 17U701 to mass.

**Note:** For checking the luminance writing current see section 1.2.14 of this chapter.

- When replacing the unit U514E, check the chrominance writing current.

#### 1.1.4. C523 (4.43-MHz oscillator, playback)

- Recorder in position playback.
- Connect YA input of oscillograph to CVBS output of pattern generator (red pattern).
- Trigger oscillograph to the Y-A input. (Adjust the time base of the oscillograph so that the sinusoidal periods can be observed separately.)
- Connect YB-input to 16U515 (E) (test point K44).
- Adjust C523 in such a way that the sine signal at the YB-inputs stands still.

#### 1.1.5. C531 (4.43-MHz oscillator, recording)

- Tune the VCR to the red pattern produced by a pattern generator.
- Short circuit junction C516-C517 to chassis.
- Connect the YA-input of the oscillograph to the CVBS output of the pattern generator.
- Trigger the oscillograph on the YA-input (adjust the time base of the oscillograph so that the sine periods of the burst signal are separately visible).
- Connect the YB-input to 16U515 (E) (test point K44).
- Adjust C531 so that the sine signal on the YB-input stands still.

#### 1.1.6. S504 (5.5 MHz filter, sound)

- Tune VCR to pattern generator.
- Modulate sound carrier on pattern generator.
- Connect a millivoltmeter to 9U508 (test point L25).
- Reduce the output voltage of the pattern generator to such an extent that the output voltage on 9U508 starts to decrease slightly.
- Adjust the coils a and b of S504 for maximum output voltage.

**Remark:**

On Introduction of U514 and U515 the 4,43 MHz oscillator has been changed to 8,86 MHz.

The adjustment procedure for C531 however, remains unchanged.

1.1.7. S505 (5.5 MHz filter, Phaft)

- Tune the VCR to the cross-hatch pattern of a pattern generator.
- Band switch in drawer U20 to channel 5-12 position.
- Sound carrier must not be modulated, Leave the drawer open.
- Make a test array as shown in Fig. III-1.
- Hints
  - Open the solder bridges A and B in the print track.
  - Disconnect R505 on one side.
  - Disconnect C510 on one side.
  - Disconnect one of the wires to SK18 (Phaft-short-circuit switch).
  - The 22 μF capacitor must be connected to the output of the time-base generator in the oscillograph. This output is at the back of the oscillograph.
  - Adjust the time-base of the oscillograph to 10 ms/div.
  - Connect the Y-input (DC) of the oscillograph to 2U508.
- Adjust the 1 MOhm trimming potentiometer in such a way that an S-curve appears on the oscillograph screen.
- Adjust the trimming cores a and b so that the S-curve is as symmetrical as possible and symmetrical with respect to the zero-axis crossing.

● Remark

The S-curve can be slightly influenced by:

- the output voltage of the pattern generator (most favourable output voltage approx. 1 mV.)
- The patterns on the pattern generator. The most favourable pattern for the PM 5508 is the cross-hatch pattern).
- The most favourable pattern for the PM 5509 is the circle pattern.

1.1.8. S705, S706 (chroma suppression filters)

- Remove plug F2 from panel 70.
- Connect a HF-generator between F21 and F22 (mass).
- Connect a millivoltmeter to 2U702E.
- Adjust the frequency of the HF-generator to 562,5 kHz, output voltage 50 mV.
- Adjust S706 to minimum millivoltmeter reading.
- Adjust the frequency of the HF-generator to 590 kHz, output voltage 50 mV.
- Adjust S705 to minimum millivoltmeter reading.

1.1.9. Determining the video heads wear

In this recorder the writing current amplifier is designed as a current source. Consequently, the writing current is constant irrespective of the impedance of the video heads. It is known that the impedance of the heads gradually decreases. This is to be attributed to the circumstance that the core material (and therefore the self-inductance) decreases because of rubbing along the tape.

When a new head disc is used the writing current will produce a certain voltage across the video heads. If the impedance decreases, the voltage across the heads will decrease. This decreased voltage indicates how much the video heads are worn. This voltage is measured on the collector of output transistor TS902.

● Measuring procedure

- Connect points 2U219 and 15U216 on the servo p.c. board (panel 20) to chassis, using the solder bridges in the print track.
- Consequently, the head disc will come to a stand-still.
- Remove the cassette holder.
- Set the VCR to recording position.
- No cassette in recorder (close SK17), cassette switch).
- Tune VCR to red pattern produced by pattern generator.

- Turn the head disc in such a way that, through a hole in the head disc, TS902 becomes accessible (see Fig. III-3)
- With an oscillograph, measure the voltage on the transistor housing (which is connected to the collector).
- For a new head disc, the voltage measured will be  $4 V_{pp} \pm 20 \%$ .
- For a worn head disc it will be  $2 V_{pp} \pm 20 \%$ .

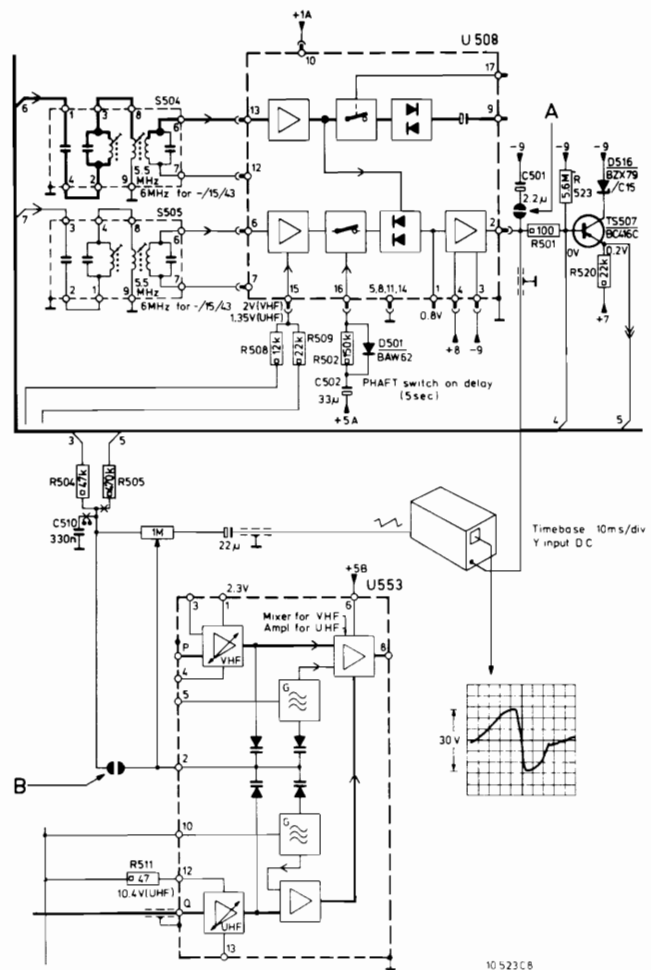



## 1.2. Adjustments in signal section (circuit units)

*Note:* All adjustments in the circuit units have been carried out very carefully in the factory. Also pre-adjustments have been performed. Below we shall mention only those adjustments which must be checked when a unit is replaced. Besides, we shall describe a checking procedure of some important adjustments which in principle need not be checked.

### 1.2.1. U505 (IF unit)

No service adjustments required.

### 1.2.2. U506 (IF detector unit)

No service adjustments required.

### 1.2.3. U507 (AGC unit)

No service adjustments required.

*Note:* When a strong local transmitter is received, it may be necessary to change the HF AGC adjustment slightly. Then readjust R11 in U507 so that the picture is displayed without distortion.

### 1.2.4. U508 (IF sound + Phaft unit)

No service adjustments required.

#### *Remark:*

After exchanging U508 or transistor TS507, it may be necessary to carry out the following check:

- Short-circuit C502 or connect junction R502, C502 to +5A.
- Tune the VCR to a TV-transmitter, preferably in the low UHF-range.
- Check if the tuning of the VCR with and without phaft is the same.
- Deviations to be corrected with R14 in U508.

### 1.2.5. U509 (automatic recording control, audio)

No service adjustments necessary.

### 1.2.6. U510 (erase oscillator + playback pre-amplifier, audio)

- Adjusting the bias voltage
  - Open SK504 by plugging in BU504.
  - Connect LF millivoltmeter to point 6BU504.
  - Recorder in position RECORDING.
  - Adjust bias voltage to 95 mV with R14 (U510).
- Adjusting the amplitude of the playback voltage
  - Open SK504 by plugging in BU504.
  - Connect an AF-generator between pins 3 and 2 (chassis) of the audio socket BU504. Output voltage of the generator  $1 V_{\text{eff}}$ .
  - Make a recording.
  - Connect an AF-millivoltmeter to point 3BU504.
  - Playback the recording.
  - The output voltage must be  $1 V_{\text{eff}}$ . Adjustments with R18 in U510.

### 1.2.7. U511 (signal preparation)

No service adjustments required.

- Checking the control amplifier
  - Tune VCR to white pattern produced by pattern generator.
  - Output voltage on 11U511 must be  $2,1 V_{\text{pp}}$  (sync positive-going). This is adjusted with R35 in U511.

### 1.2.8. U512E (562.5 kHz processor)

No service adjustments required.

### 1.2.9. U513E (reference processor)

- Burst key adjustment

#### Method 1

- Connect YA-input of oscillograph to 10U515 (E) (measuring plug K41).
- Connect YB-input of oscillograph to 16U506 (measuring plug L21).
- Tune VCR to transmitter signal.
- Adjust with R7 the leading edge of the burst key so that it will appear  $5,2 \mu\text{s} \pm 0,2 \mu\text{s}$  after the leading edge of the line pulse.

#### Method 2

- Tune the VCR to the colour bar pattern of a pattern generator.
- Connect an oscilloscope to 2U514 (E).
- R7 in U513E to be so adjusted that the amplitude of the chroma signal at 2U514 (E) is minimum.

### 1.2.10.1. U514E, U515E (see Fig. III-2a)

- Adjusting the chroma amplitude.
  - Tune the VCR to a colour signal.
  - Connect an oscillograph to 5U515E.
  - The burst amplitude must be 600 mVpp, adjustment with R17 in U515E.
  - Chroma led D302 must light up.

#### *Remark:*

- The chroma amplitude must be adjusted when U514E or U515E is exchanged.
- When U514E is exchanged, also the chrominance writing current must be checked (see 1.1.3.).

### 1.2.10.2. U514, U515 (see Fig. III-2b)

- Adjusting the chroma amplitude
  - Tune the VCR to a colour signal.
  - Connect an oscilloscope to 2U514.
  - The burst amplitude at 2U514 should be 600 mVpp.
  - Adjustments with R21 in U515.

### 1.2.11. U551 (UHF modulator)

- General

The modulator carrier frequency has been factory-adjusted to 600 MHz (channel 37). For this frequency the modulator has been balanced to a maximum. When there are interferences between the modulator carrier and a local transmitter the modulator must be tuned to a vacant channel. Then, the modulator must again be balanced to a maximum.

- Adjusting method when modulator carrier frequency has to be tuned to another frequency
  - Starting position: combination of TV-VCR. TV tuned to modulator frequency of VCR.
  - Apply colour bar pattern from a pattern generator to aerial input of VCR. Select frequency of applied signal preferably in VHF range – for example, channel 8. Do not modulate the sound carrier.
  - Tune VCR to applied signal.
  - Connect instead of pattern generator an aerial to VCR.
  - If then a transmitter is received by TV, detune TV until transmitter is not received any more. Do not detune more than about 5 channels.
  - Reconnect pattern generator to aerial input of VCR.
  - Adjust C453 on the modulator unit so that a correctly tuned picture is displayed on TV

- Notes:**
- o The TV set must be tuned to upper side-band of modulator signal.
  - o If the modulator frequency must be increased, turn out the core of C453. To decrease this frequency, turn in the core.
  - o If no synchronised picture can be obtained, perform the first two operations mentioned below:
- Change pattern produced by pattern generator to grey scale.
  - Using C208 on modulator unit, make the white bar in the picture as white as possible.

**Note:** To trim C208, use a plastic tool only.

- After having carried out these aforementioned operations, change pattern on pattern generator again to colour bar pattern.
- It is then possible that several bars have other colours. Using balance control R311 on modulator unit, restore the original yellow bar as well as possible. The brightness of the picture must not decrease.
- Set volume control of TV to maximum.
- Using C208, adjust for minimum sound interference.

#### 1.2.12. U552 (aerial amplifier)

No service adjustments required.

#### 1.2.13. U553 (channel selector)

No service adjustments required.

#### 1.2.14. U701 (FM recording processor)

No service adjustment required.

- Checking the luminance writing voltage
- Tune the VCR to a white pattern produced by a pattern generator.
- Cassette in recorder.
- Connect oscillograph to 3U701 (measuring plug F13).
- VCR in position RECORDING.
- Luminance writing voltage must be 1 V<sub>pp</sub> (adjusted with R27 in U701).

#### 1.2.15. U702E (FM playback processor)

No service adjustments required.

- Checking the drop-out compensator switch-on level
- Playback black/white test pattern of premodulated service test cassette 4822 397 60042.
- Field 2 in zone 2 must be white and field 3 must be black.
- The switch-on level is adjusted with R22 in U702E.

**Note:** For a description of the test pattern of test cassette 4822 397 60042 see Service Information VR75-03.

When U702E is exchanged, the residual carrier suppression in U703 must be checked (see 1.2.16).

#### 1.2.16. U703 (FM demodulator, main channel)

- Adjusting the residual carrier wave suppression
- Connect an oscillograph to 1U703.
- Playback a recording.
- With R4 in U703, adjust residual carrier wave signal to minimum.

#### **Remark:**

The most favourable spot in the video signal for adjusting to minimum residual carrier wave is the back porch of the line pulse.

- Checking the output voltage
- Record a white pattern produced by a pattern generator.
- Playback the recording.
- Connect oscillograph to 1U703.
- Output voltage on 1U703 must be 2.5 V<sub>pp</sub>. (Adjustable with R15 in U703).

**Note:** When U703 is replaced, check grey level adjustment in U704. See section 1.2.17.

#### 1.2.17. U704 (FM demodulator, drop-out channel)

Grey level adjustment with respect to main channel.

- Method 1
- Playback black/white test pattern of premodulated test cassette 4822 397 60042.
- Using R15 in U704, adjust field 4 in zone 2 so that it is evenly gray.

#### **Remark:**

For a description of the test patterns of test cassette 4822 397 60042, see Service Information VR75-03.

- Method 2
- Record a red pattern produced by a pattern generator.
- Playback the recording.
- Switch on colour killer on TV receiver.
- Recorder in position STOP MOTION.
- With R15 in U703, make the parts of the interference zone filled-up by the drop-out compensator, grey (the same as the rest of the picture).

#### 1.2.18. U721 (crispening unit)

No service adjustment required.

- Checking the crispening strength
- Record red pattern produced by a pattern generator.
- Connect oscillograph to 6U721.
- Playback the recording.
- Overshoot and undershoot of the black/grey transition must be about equal and must not exceed 10 % of the transition.
- The crispening strength is adjusted with R26 in U721.

#### 1.2.19. U822 (AGC unit)

No service adjustments required.

- Checking the output voltage
- Supply a video signal (white pattern) of a pattern generator to CVBS input BU803.
- Set to video recording position (press channel selector pushbutton 8).
- The output voltage on 17U822 must be 2,5 V<sub>pp</sub>, adjustable with R27 in U822.

#### 1.2.20. U823 (splitter)

No service adjustments required.





PANEL 70

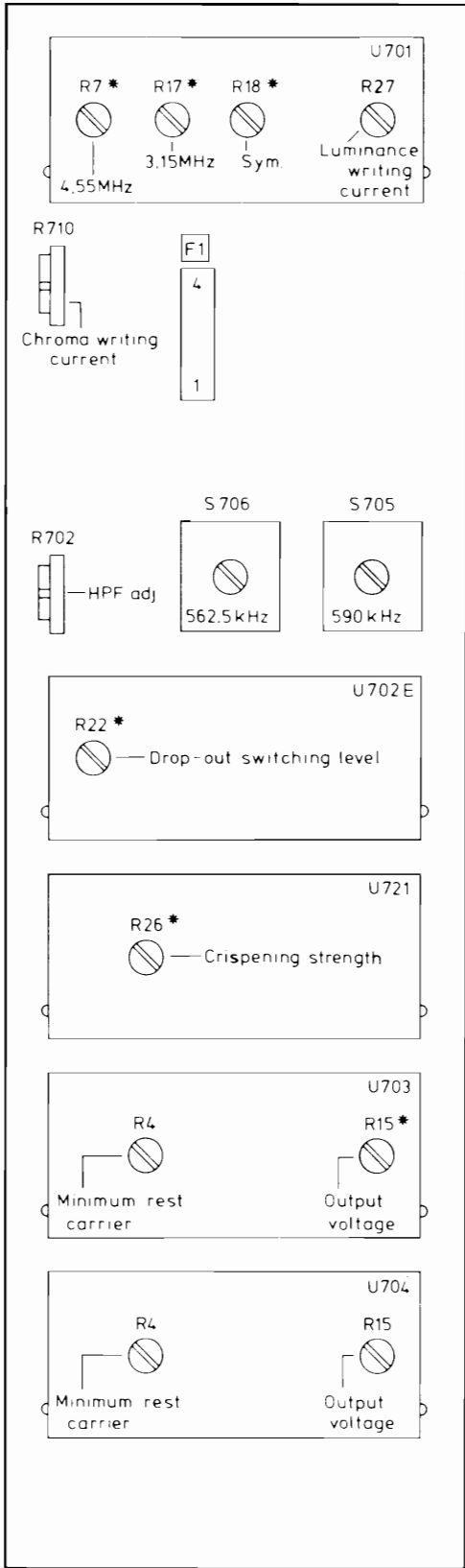

\* No Service adjustment

10 279 C 13

PANEL 80

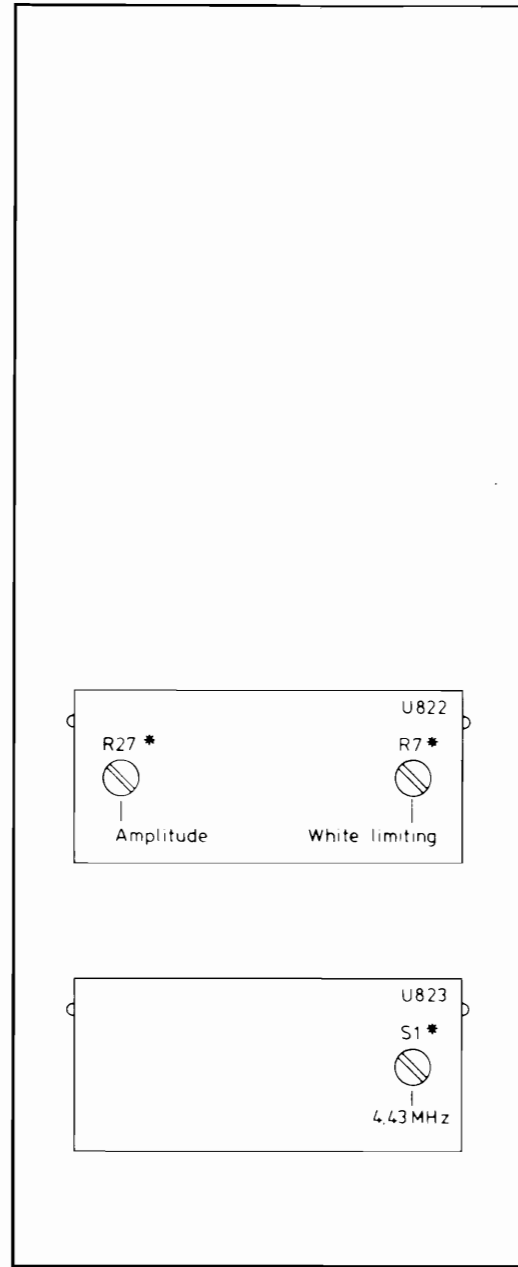

\* No Service adjustment

PANEL 90

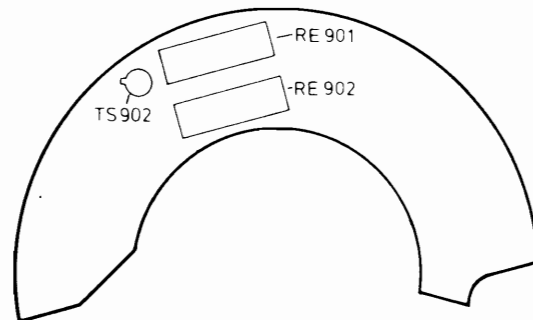

10 280 C 13

1-3 - ADJUSTING THE SERVO-SYSTEM  
(PANEL 20).

*General.*

- Recorder should be in horizontal position.
- VCR in recording position, unless otherwise indicated.
- No cassette inserted, unless otherwise indicated.
- The adjustment components are fitted in the units and accessible from above, as shown in the drawing.
- The 2 tags - bottom left - can be broken off and then serve to block the switches SK201 and SK202 with panel 20 hinged out.
- By inserting a piece of wire of e.g. a resistor, from the track side of the PC-board through the corresponding hole, the test points of the test blocks B3 and B4 are within easy reach.

1.3.1. Adjusting the head servo system (U219)

a. Position of the picture gap.

- Make a recording of a white pattern and play it back.
- Remove U704 (panel 70)
- Connect an oscillograph to L21 (panel 50).
- Trigger the oscillograph externally with the signal on B43 (time base x5).
- The picture gap must be visible between 8 to 12 line durations before the frame pulse
- Should the picture gap occur earlier or later, then adjust R9 of U219 as follows:
- Connect an oscillograph to B41 and trigger externally with the signal on B43.
- On the picture screen of the oscillograph the scanning pulse is now visible.
- Is the picture gap e.g. 3 line durations (= 192  $\mu$ sec) too early (farther away from the frame pulse) then the scanning pulse should be moved 3 line durations to the right. Adjustments with R9 of U219.
- Is the picture gap e.g. 3 line durations too late (closer to the frame pulse) then, with R9 of U219, move the scanning pulse 3 line durations to the left.
- Make a new recording of a white pattern and play it back
- Check the picture gap again and, if necessary, correct the adjustment of R9 of U219 as indicated above.
- Refit U704 on panel 70.

If a stroboscope is available, the following method can be applied:

- Remove the cassette lift
- By hand, move bracket 516 to the left and block it, e.g. with one of the tags of panel 20
- Switch on the recorder and, by hand, push down bracket 525 for a moment and press the playback and the recording key.
- Apply the signal of a pattern generator to the VCR.
- Connect the trigger input of the stroboscope to the sync. output (frame) of the pattern generator.
- Light the head disc with the stroboscope
- The video heads are now visible near the last mounting screw of the drum ruler.
- Adjust R9 of U219 in a way that, measured in rotation direction of the head disc, the distance between the mounting screw and the gap of the video heads is 4,2-5,3 mm (see Fig. III-4).
- Refit the cassette lift.

*B. Ripple voltage*

- Connect an oscillograph to B31
- Set R2 of U219 to minimum ripple in the oscillogram shown.

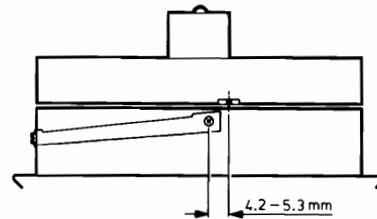

Fig. III-4

1.3.2. Adjusting the tape servo system (U220)

a. Flywheel pulse.

- Connect an oscillograph to B12.
- Adjust the distance between servo head K7 and the magnets on the flywheel in such a way that the peak-to-peak value of the oscillogram is 650 - 700 mV

Remark: When replacing K7 please note the polarity of the pulse given (see Fig. III-5).

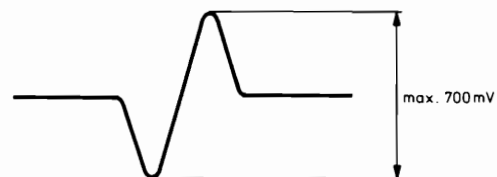

Fig. III-5

b. Position detector.

- Connect the Y-A input of a double-beam oscillograph to B42.
- Connect the Y-B input to B43
- Trigger the oscillograph to the positive going edge of the signal on the Y-B input
- Adjust R7 of U220 is such a way that the distance between the negative going edge of the scanning pulse on B42 and the positive going edge of the reference pulse on B43 is  $4 \pm 0,5$  msec.

c. Ripple voltage.

- Connect an oscillograph to B32
- Set R3 of U220 to minimum ripple in the oscillogram shown.

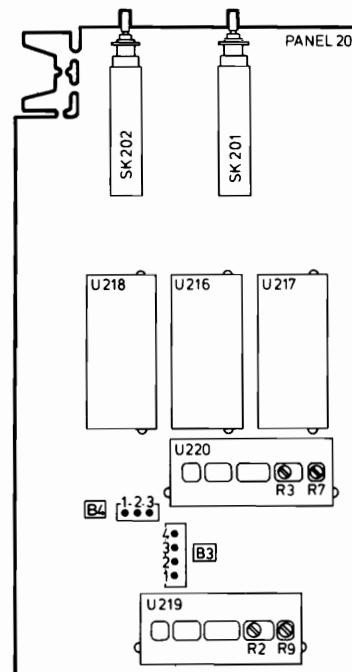

Fig. III-6

1-4 - ADJUSTING THE POWER SUPPLY SECTION (PANEL 10).

1.4.1. Set to the mains voltage required

- All recorders, except the /15, are set to a mains voltage of 220V by the factory, the /15 is set to a mains voltage of 240V.
- When another mains voltage is required, please see the sticker at the chassis bottom.
- The strips with possible mains voltages can be torn off and stuck on the type plate at the back of the recorder.
- Under codenumber 4822 401 10632 a cable binder is supplied to tie together the wires of the primary windings of the transformer.

Remark: Always observe the national security safety regulations.

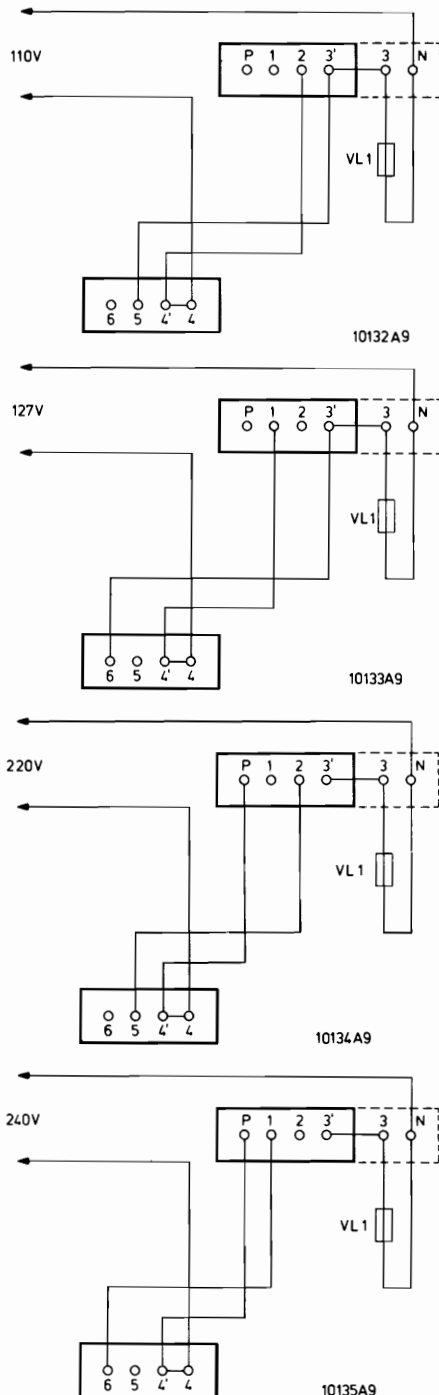

Fig. III-7

1.4.2. Adjusting the supply voltages

After repairing one of the voltage stabilizers on panel 10, the supply voltage should be checked. When the supply voltages exceed the tolerances given, readjustment of the stabilizers is called for.

a. Adjusting the + supply voltage ( $12 \pm 0,1$  V).  
- VCR in recording position.

- From the following series of resistors, choose values for R112 and R113 so that the voltage on MP109 is  $12 \pm 0,1$  V.
- Choice series R112-R113: 27 k $\Omega$  - 39 k $\Omega$  - 56 k $\Omega$  - 100 k $\Omega$

All resistors mentioned are standard 5%-1/4 W carbon resistors.

b. Adjusting the + 7 supply voltage ( $27 \pm 0,1$  V).

- VCR in recording position.
- From the following series of resistors, choose values for R120 and R121 so that the voltage on P54 is  $27 \pm 0,1$  V.

Choice series R120-R121: 56 k $\Omega$  - 100 k $\Omega$  - 150 k $\Omega$  - 270 k $\Omega$  - 560 k $\Omega$

All resistors mentioned are standard 5%-1/4 W carbon resistors.

1-5 ADJUSTING THE TIMER.

The free-running frequency of the astable multivibrator TS326 and TS327 should be adjusted as follows:

- The timer must be battery-operated.
- Apply the oscillator signal of point 27 of IC321 to the input of an oscillograph
- Trigger the oscillograph externally with a signal with the mains frequency (e.g. from a soldering transformer).
- Press button SK316 (activate). D321 now lights up.
- Take out the mains plug.
- Now adjust R350 in such a way that the picture on the oscillograph screen stands still.

Remark: After repair, care should be taken that the clock is non-activated before the mains plug is taken out. Otherwise, the battery will be discharged.

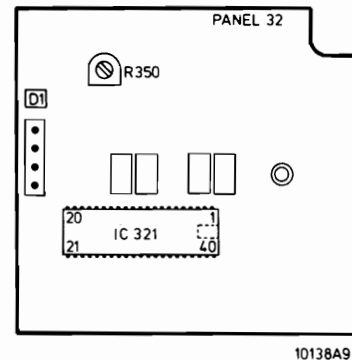

Fig. III-8



## 2. MECHANICAL ADJUSTMENTS AND CHECKS

### 2.1. Tape deck

#### 2.1.1. Important

The lower head drum 158 is inclined  $3^{\circ} 41'$  from the cassette plane in the threaded-in condition. To this end different washers have been fitted under the drum guide rollers (marked  $\circ$  in fig. III-9). When removing the guide rollers or the lower drum, one should ensure that the rollers are kept in sets and replaced in the same position on reassembly.

#### 2.1.2. Decasing N1502

##### a. Top plate

- Open the cassette compartment by pushing the ejector button.
- Turn loose entirely the screws item 119 – item 130 on the back of the recorder. (N.B. These screws cannot be removed from the cover. Slightly lift the top plate item 101 and push it away backwards).
- Remove the screws item 21 + 134 and take off the edge item 102.

For remounting, reverse the sequence.

*N.B.* When mounting the cassette compartment cover, take care that the tags on the left hand side of the holder fit well in the corresponding slots of the cover.

##### a. Bottom plate

- Recorder in upright position.
- Remove the 2 mounting screws of the service panel.
- With a screwdriver, push down the 2 tags of the panel locking and remove the panel, item 118.

*Important:* When mounting the service panel the two screws must be fixed again (safety demand).

#### 2.1.3. Remarks

- On playback, with the lift not mounted, disturbance may be visible on the screen. This is caused by discharge of static electricity. Normally, this static electricity is discharged by the carbon contact on the lift.
- Removing the switches.

The microswitches are spring-mounted. For demounting, press down the spring plates and push off the switches. When mounting, take care that the pin on which the switch is mounted, is behind the barbs on the spring plate.

The recorder can be used without lift, when:

- a. the spring item 150 (fig. V-4) is taken off the hook item 169.  
The hook should be pushed flat against the chassis.
- b. the switch SK11 is operated by bracket item 516, to be blocked in right hand position by inserting a suitable object between this bracket and SK11.
- c. bracket item 525 is pushed down by hand, before the rewind, start or wind keys are pressed.

#### 2.1.4. Threading mechanism

- Loosen screws A (fig. III-9) on toothed bracket 281 some turns and slide the bracket as far as possible to the right.
- Loosen the screws of threading motor unit 280 some turns and rotate this unit so far clockwise that the toothed wheel of the threading unit no longer engages with the gear ring on the lower drum.
- By manually rotating the lower drum, check that it moves smoothly and without play through the guide. When the drum moves heavily, the drum and the guide wheels must be inspected.
- Check that by rotating the threading mechanism, the toothed wheel of this mechanism engages with the gear ring of the lower drum.
- After carrying out this adjustment, check again that the lower drum can be easily rotated by hand.
- Adjust bracket 281 (fig. III-9) so that its teeth are engaged with the gearwheel of the threading unit leaving just perceptible play. Secure the length of bracket 281 by tightening screws A (fig. III-9).

#### 2.1.5. Checking the drum stop

Loosen the screws A on toothed bracket 281 (fig. III-9) a few turns and slide this bracket as far as possible to the right.

Check that stop bracket 241 of the lower drum (fig. III-10) is moved out symmetrically by the pins of the lower drum when the drum is manually turned in and out. If necessary, readjust symmetry by bending bracket 242.

Readjust the toothed bracket as described in 2.1.4.

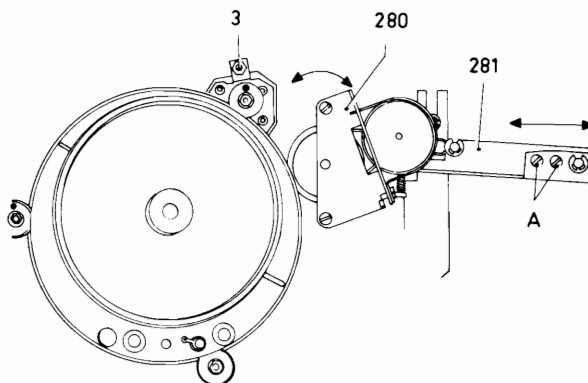

10490A14

Fig. III-9

### 2.1.6. Idler wheel 217

- Set the recorder to position PLAY.
- Check that there is a clearance of 1.0 mm between the arm of idler wheel bracket 197 and bracket 522. If necessary, readjust the idler wheel with eccentric screw A (fig. III-11).
- Set the recorder to position OFF. Hook 512 must be adjusted so that the idler wheel 217 is not in contact with the flywheel and the hysteresis coupling. (In position "ON" the idler wheel 217 must be released by the hook 512).

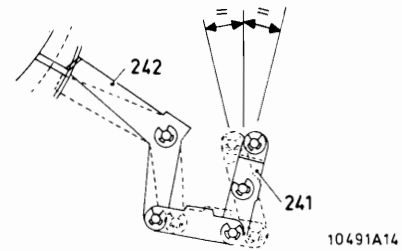

Fig. III-10

### 2.1.7. Checking the cassette-unlocking mechanism

Set the recorder to position OFF.

The centre-to-centre distance between the pin of the cassette-unlocking mechanism and the cassette support pin must be  $11.5 \text{ mm} + 0.5 \text{ mm}$  (see fig. III-12).

If necessary, readjust this distance by (1) loosening screw 16 some turns and (2) sliding bracket 255 relatively to bracket 227. These, screw 16 must be tightened again.

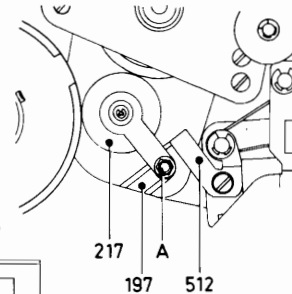

Fig. III-11

### 2.1.8. Checking the eject-knob mechanism

Recorder in position OFF; cassette compartment closed.

In this position it must be possible to press both the eject knob and the play key. However, when the play key is pressed, the eject key must be blocked.

If necessary, bend the adjusting tag of plate 525 (see fig. V-4).

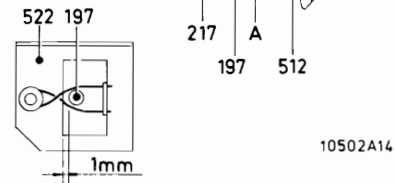

### 2.1.9. Checking reel disc-brake

With an energized RE1, the clearance between bracket 205 and the stop of bracket 206 must be  $0.5 + 0.2 \text{ mm}$ .

If necessary, carry out a readjustment as follows:

- Loosen the fitting screws some turns.
- Slide RE1 in the direction of the arrow (see fig. III-13).

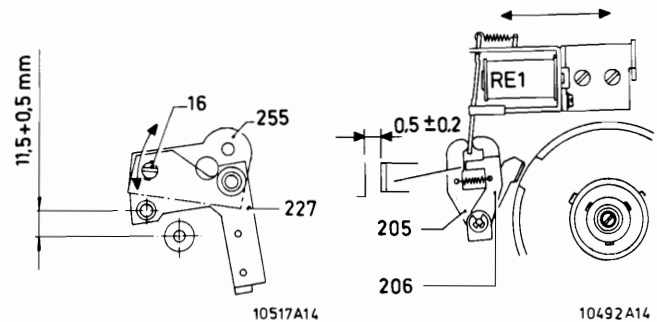

Fig. III-13

### 2.1.10. Solenoid S5

Check the stroke of the armature of solenoid S5 by measuring the distance denoted by D in fig. III-14. This distance must be  $1.5 + 0.5 \text{ mm}$ .

If necessary, readjust the distance by bending stop plate B.

Check that the tag C of the armature of S5 does not touch the edge of the hole in bracket 507 when the ON-knob has been set to ON (see fig. III-14). If necessary, readjust the tag C of the armature of S5.

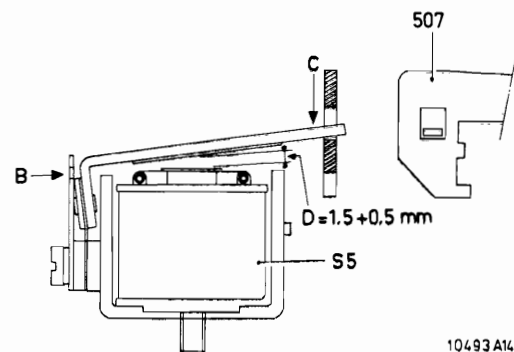

Fig. III-14

### 2.1.11. Solenoid S6

Check the stroke of the armature of solenoid S6 by measuring the distance denoted by D in fig. III-15. This distance must be  $1.5 + 0.5 \text{ mm}$ .

If necessary, readjust this distance by bending stop plate A.

Press the record and the play keys and check that they are properly released when the armature of S6 is pushed on the core of the coil. If necessary, readjusted set screw B.

To this purpose press the record and the play key and push the armature of S6 by hand on the core of the coil. Then turn screw B so far that the record and the play key are just released. Next, turn screw B further through about  $180^\circ$  and lock screw B with nut C.

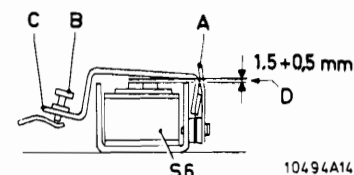

Fig. III-15

### 2.1.12.

Check if the play between chassis and adjusting screw item 3 (fig. III-9) is  $0.5 - 0.2$ . Readjust screw item 3, if necessary.

### 2.1.13.

Check that the threaded in tension of the lower drum is 1 kg. This must be measured on pin N of the lower drum.

## 2.2. Switches

### 2.2.1. Checking the "ON" switch

When the "ON" switch is operated, the contacts of SK3 must be closed. This can be adjusted by moving bracket 193 (Fig. III-16)

### 2.2.2. SK12,SK13 - Threading-in mechanism

Check if after the threading out procedure SK12 is only then operated when spring item A (Fig. III-17) is under tension. If not, mounting bracket item 271 of the switch SK12 must be moved.

Check if, after the threading-in procedure, SK13 switches before the spring A is under tension. If not, move the tensioning ring on the switch pin B.

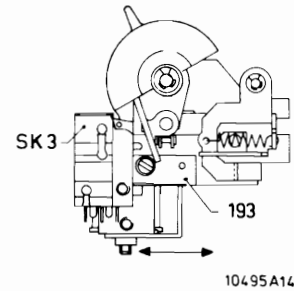

Fig. III-16

## 2.3. Tape path checks and adjustments

### 2.3.1. Adjustment of the lace-up

#### General information

All checks and adjustments must be carried out at nominal mains voltages and in a horizontal position of the VCR.

The following aids are required to adjust the lace-up:

- Service test cassette with recesses 4822 397 60041. This cassette contains 200 metres of non-modulated test tape.

- Service test cassette with 100 m of pre-modulated test tape 4822 397 60042. Three test signals have been modulated on the tape, each signal covering a length of 33 m. This corresponds to a playing time of 4 minutes for each test signal. These test signals have the following functions:

#### Test signal A (0-33 m)

On this part of the tape, a 400 Hz squarewave signal has been modulated. This signal, erased in the area of the sync track, serves to adjust the height of the audio/sync head.

*Note:* During production, the frequency of the squarewave signal has been changed to 274Hz.

On the audio-track, a 12.5-kHz signal has been modulated. This signal serves to adjust the azimuth of the audio/sync head.

#### Test signal B (34-67 m)

On this part of the tape, a black-white test pattern has been modulated. With this signal the luminance-playback section of the recorder can be checked.

On the audio-track a 3150 Hz signal has been modulated. This signal serves to measure the tape speed and the wow and flutter.

#### Test signal C (68-100 m)

On this part of the tape, a colour test pattern has been modulated. With this signal the chrominance-playback section of the recorder can be checked. Besides, a 3150 Hz signal has been modulated on the audio track.

- Drum level tube 4822 395 80131. With this level tube the recorder is placed in its reference position. All static lace-up adjustments must be performed in this reference position.
- Level tube 4822 395 50128 is used to check all other perpendicular adjustments.
- Bending tube 4822 395 80151 is used for the adjustment of the two cassette roller spindles.
- Bending tube (4822 395 90152). For the adjustment of the reel disc shaft bearing.
- Gauge 4822 395 80077 is used to carry out the height-adjustment of the two reel discs.

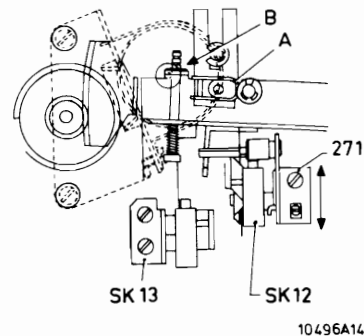

Fig. III-17

- Mirror with illumination lamp to check the lace-up  
Type number SCP62, code number 4822 395 30062  
Code number of separate illumination lamp 4822 134 40324.
- Square for pre-adjusting the audio sync head and tape guide, item 278, code number 4822 395 80078.
- Measuring pin for idler wheel 217, code number 4822 395 80076.
- Spring pressure gauge 0 - 35 g 4822 395 80029
- Spring pressure gauge 10 - 100 g 5322 395 84011
- Spring pressure gauge 300 - 3000 g 5322 395 84009
- Allen key 2 mm 4822 395 50084
- Cleaning set N1102/30

Before the lace-up is checked or adjusted, all metal parts that come into contact with the tape must be cleaned (see the operating instructions). All adjustments must be carried out in the prescribed order.



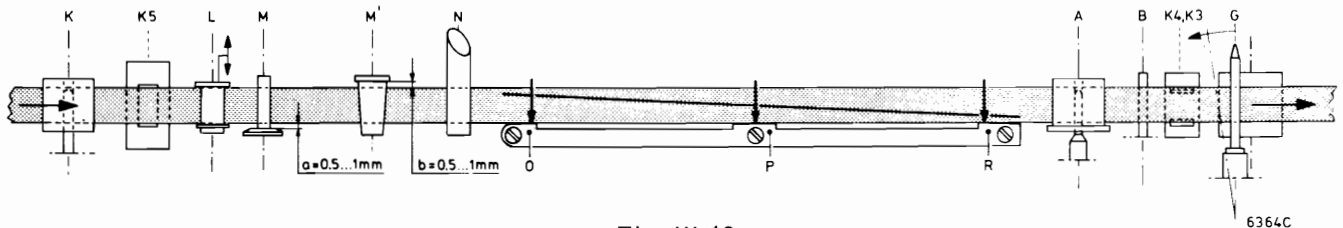

Fig. III-18

### 2.3.2. Static adjustment and check

All tape guide components are accurately adjusted and locked. If lace-up faults occur, first establish the cause to prevent that unnecessary readjustments are carrier out.

The drum ruler (with cams O,P and R) (Fig. III-18) has been accurately factory-adjusted.

The ruler cannot be adjusted or checked for position by the Serviceman. It will be necessary to replace the complete Lower Drum if the ruler is bent, worn or the securing screws have been disturbed. If after carrying-out lace-up adjustments the recorder will not produce compatible recording, it may also be necessary to replace the lower drum.

### 2.3.3. Reference position of the recorder

- Place the recorder on a stable and flat surface.
- Set the recorder to position THREADED and disconnect the main plug. Remove the cabinet and the cassette holder.
- Remove the head drum 151 (Page V-4).
- Place drum level tube 4822 395 80131 on the lower drum section. Make sure that the central pin of this level tube engages with the shaft bearing of the head drum and that the outer pin engages in the corresponding hole of the lower drum section. First clean the contact faces between the drum and the level tube thoroughly.
- Place the jig for measuring the reel disc height in the recorder.
- Place the recorder level, using, the level tube fitted on this jig.
- Check with the head drum level tube whether the lower drum is in the correct position. If not, the position of the lower drum must be readjusted. To do this, place more rings or remove rings 35-38-40 under the drum guide rollers 160 and 174 (Page V-4). When the lower drum is in its right position (bubble of the heads drum level tube as exactly as possible in the centre of the red circle), this is the reference position for other adjustments.

### 2.3.4. The following parts must be adjusted to be perpendicular

(To be checked with level tube 4822 395 50128)

- Cassette roller spindles A and K (Fig. III-18,19). If necessary, these spindles can be adjusted with bending tube 4822 395 80151. This tube has a hole on both ends. The largest hole serves for spindle A and the other hole for spindle K. Slide the tube over the spindles as far as possible but be sure that the tube does not touch the chassis.

### 2.3.5. The reel disc shaft bearing

To check the position of the bearing, remove the reel discs 218 and 221 (Page V-4). Be sure that the assembly of the set of washers 222-225 and of the set of washers 219,220 is not changed. Otherwise the height adjustment of the lower reel discs is no longer correct. If the reel disc bearing is not exactly perpendicular to the lower drum plane, bend it to its right position with bending tube 4822 395 90152.

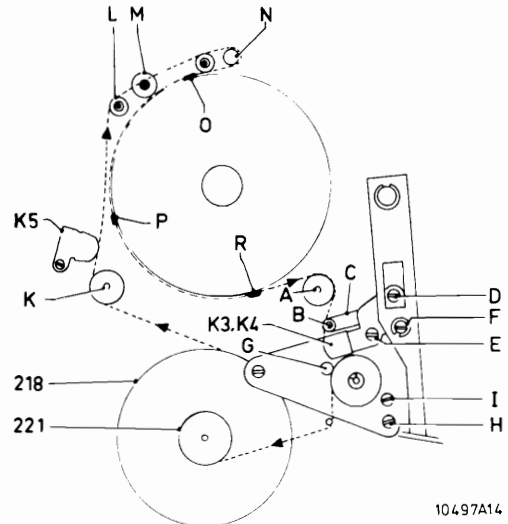

Fig. III-19

### 2.3.6. Idler wheel 217

Remove the idler wheel. Insert measuring pin 4822 395 80076 (dia 2 mm) into the bearing of the idler wheel. Check with level tube 4822 395 50128 that the measuring pin is perpendicular to the lower drum plane. If necessary, readjust the position of the pin by bending the metal bracket on which the bearing is fitted.

### 2.3.7. Capstan G

Adjust the capstan so that it tills by about 20' towards the heads drum.  
 Preadjustment: Adjust the capstan perpendicular, using screw H. Then turn screw H a quarter of a turn counter clockwise.

### 2.3.8. Audio/sync head

Place the plate for measuring the reel disc height (4822 395 80077) in the recorder. Press the play key and place square 4822 395 80078 on the ground place of the jig. Adjust the audio/sync head, by means of the jig. Adjust the audio/sync head, by means of three set screws, so that it is parallel to the straight side of the square; the height of the audio head must correspond to the mark on the square.

*Note:* If no square is available, the audio-sync head can be readjusted with level tube 4822 395 50128. The exact adjustment of the audio/sync head is carried out during the dynamic lace-up adjustment 2-3-18. To this purpose an electrical test cassette 4822 397 60042 is used.

### 2.3.9. Tape guide B

Check the position of tape guide B with square 4822 395 80078. Readjust the position of the tape guide by bending the mounting bracket with a screw-driver.

*Note:* If no square is available, check the vertical position of tape guide B with level tube 4822 395 50128.

2.3.10. Insert depth of the audio/sync head

For this adjustment a jig as shown in Fig. III-20 is needed. To make this jig, use a machine-cut strong piece of paper (for example, a post card). Press the play key. If then the long right-hand side of the jig is pushed against the cassette roller spindle and if mark A is exactly opposite the right-hand spindle, the audio/sync head must just touch the short side of the jig (Fig. III-21). Readjust the insert depth; if necessary, by bending bracket 286 (Fig. III-21). After carrying out this adjustment, remove the drum level tube and fit the head drum.

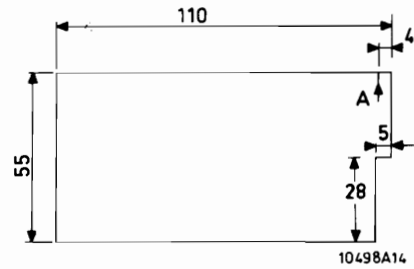

Fig. III-20

2.3.11. Reel disc height

a. Lower reel disc

Place the jig for measuring the reel disc height in the recorder and measure distance B as shown in Fig. III-22. Use for this tail of a caliper gauge. Check likewise the distance B at the point diametrically opposite the first test point. These two distances must be equal. The distance B can be varied by adding or taking off rings, items 222, 223, 225. Check also the vertical play of the lower drum. It should be 0.15 mm, to be adjusted with the rings items 219-220.

b. Upper reel disc

Check the distance A with the measuring plate for the height of the reel disc and a caliper gauge. Correct possible deviations by adjusting the thrust bearing item 239 (Fig. III-22).

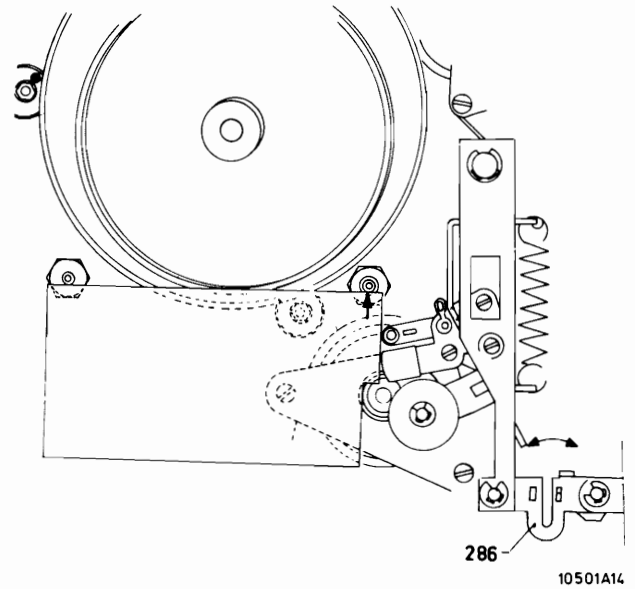

Fig. III-21

2.3.12. Pressure roller

Set the recorder to threaded-in position and press the play-key. Check the pressure force of the pressure roller (Fig. III-23). It should be  $1900 \pm 200$  g. When the pressure force is outside the tolerances, spring item 283 must be replaced.

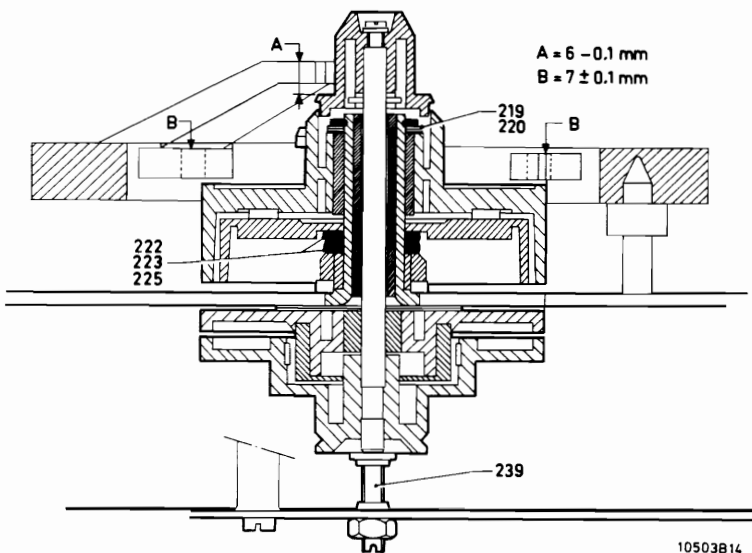

Fig. III-22

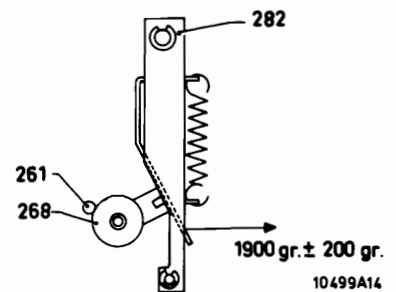

Fig. III-23

2.3.13. Remark

Frictions and tensile powers are measured with a spring pressure meter. Under radius is understood the distance between the centre of the reel and the point where the force must be measured (see Fig. III-24). The force at a radius of 5,5 cm can be measured with a full reel and, at a radius of 2 cm with an empty reel. At the end of the tape a loop can be made of adhesive tape for hooking in the spring pressure meter, see Fig. III-24.

2.3.14. Counter-friction torque of the upper reel disc

Recorder in rewind position. Put on a loose reel (top reel from a cassette) with some metres length of tape on the upper reel disc. The counter-friction torque must be 25 g, measured anti-clockwise at a radius of 2 cm. When the value measured is different, adjust the counter-friction torque by hooking spring item 275 into another hole of bracket item 274 (Page V-4).

2.3.15. Winding friction

Put on a loose reel (top reel from a cassette) with some metres length of tape on the upper reel disc. Recorder in play-back position. The winding friction force must be  $40 \pm 10$  g, measured at a radius of 2 cm. If the value measured is outside the tolerances, replacement of the complete friction item 235 is necessary.

2.3.16. Counter-friction torque of the lower reel disc

Recorder in play-back position. Put on a loose reel, with full length of tape (bottom reel from a cassette) on the lower reel disc. The rewind friction force must be  $20 \pm 5$  g, measured anti-clockwise with a radius of 5.5 cm. When the value measured is outside the tolerances, reel disc item 221, or friction disc item 221 must be checked.

2.3.17. Reel disc brake

When the reel disc brake is applied, the friction force (anti-clockwise) must be 40 g at a radius of 5.5 cm. When the value measured is different, the reel disc brake must be checked and, if necessary, readjusted. See point 2.1.9.

2.3.18. Dynamic tape path adjustment

- On the servo panel, close the soldering bridge A and open soldering bridge B (Fig. III-26).
- Insert the service test cassette with recesses (4822 397 60041)
- Switch on the recorder and set to play-back position.
- Check if tape guide M' is adjusted low enough. The distance a (see Fig. III-18) must be 0.5...1 mm.
- Check if tape guide M is adjusted high enough. The distance b (see Fig. III-18) must be 0.5...1mm.
- Adjust tape guide L in such a way that the tape just touches cam P of the drum ruler. Then turn tape guide L clockwise for abt.  $135^\circ$ .

Remark:

In Fig. III-18, arrows indicate the spots on the cams O, P and R where, with a mirror, should be checked if the tape touches the cams correctly.

- With screws H adjust the inclination of capstan G in such a way that the tape just touches cam R of the drum ruler. Then turn screw H anti-clockwise for abt.  $150^\circ$ . Tighten the locking screw. Check again if the tape runs stable and without twisting on the supports of the ruler.

- Adjust the tape guide M in such a way that the flange just not touches the top of the tape.
- Adjust the height and the azimuth of the audio-sync head.

2.3.19. Adjusting the audio/sync head (see Fig. III-19)

East-West adjustment

This was already performed during the static lace-up adjustment.

Final height adjustment

- On the servo panel, close the soldering bridge A and open soldering bridge B (see Fig. III-26).
- Insert the Service test cassette with premodulated tape (4822 397 60042) into the recorder.
- Connect an oscilloscope or milli-voltmeter to test point B33 (see diagram B).
- Play back the first third of the tape.
- Adjust the audio/sync head for minimum signal at test point B33 by turning the screws E and F and screw D equally far in or out.

Azimuth adjustment

- Insert the Service test cassette with premodulated tape (4822 397 60042) into the recorder.
- Connect a milli-voltmeter, via an RC-filter, to point 3 or 5 of BU504 (see Fig. III-25).
- Playback the first third of the tape.
- Adjust the audio/sync head for maximum voltage on point 3 or 5 of BU504 by means of screw D.

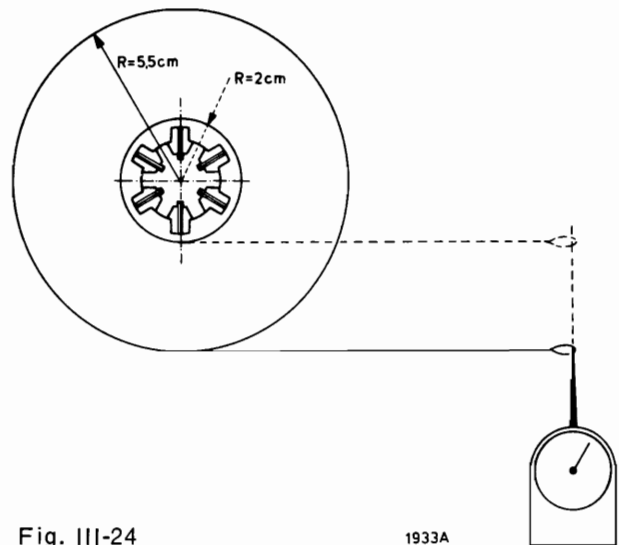
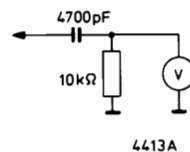

Fig. III-24

1933A



4413A

Fig. III-25

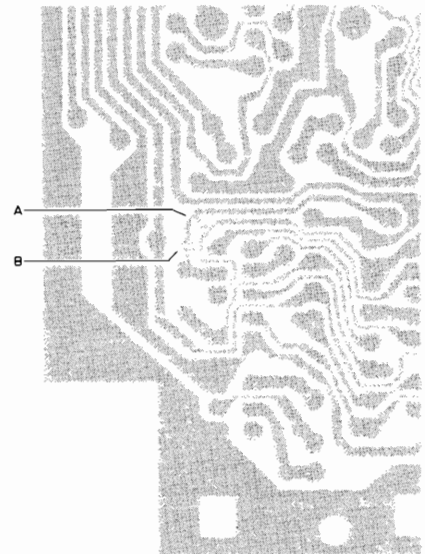

Fig. III-26

1097B8



**Checking the distance capstan-pressure roller**

If the apparatus is switched-on by the electronic clock (start push-button and recording push-button are both pressed then) the distance between capstan and pressure-roller must be  $> 0,3$  mm during the threading-in procedure. When the start push-button is pressed with the set threaded-in, the distance between plate 560 and bracket 269 must be  $> 0,5$  mm.

This can be adjusted by shifting plate 560 with respect to bracket 282A after loosening screw 14 a few turns.

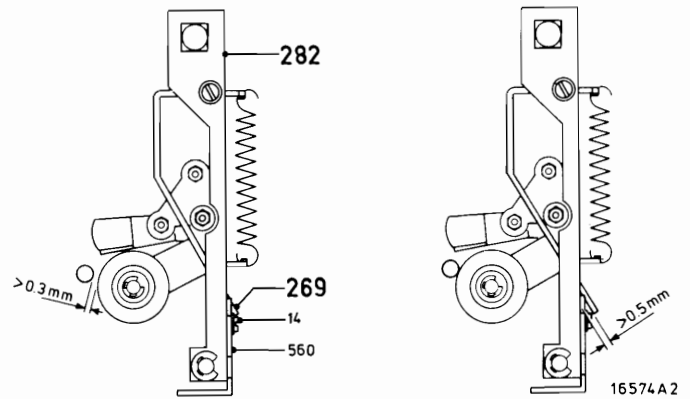

**Pressure roller 268**

- Switch-on the set and press the recording key.
- Open SK11 after 3 to 5 secs.
- Place level 4822 395 80083 on the pressure roller.
- Check the horizontal position of the pressure roller in East/West direction.
- The air bubble of the level in East/West direction must be within the outer adjustment ring.
- Adjustments can be made with the adjusting screw 8.
- Let the apparatus run for 3 to 5 seconds by closing SK11.
- Check the position of the pressure roller again and, if necessary, repeat the adjustment described above.

**Audio/sync. head**

- Switch-on the set and press the playback key.
- Place square 4822 395 80078 on the ground plane of the reel disc height gauge.
- Check that the face of the audio/sync. head is parallel to the measuring side of the square.
- Adjustments can be made by turning nut E in or out.
- Check that the audio head is on the same height as the marking on the square.
- Adjustments can be made by turning nut F in or out.

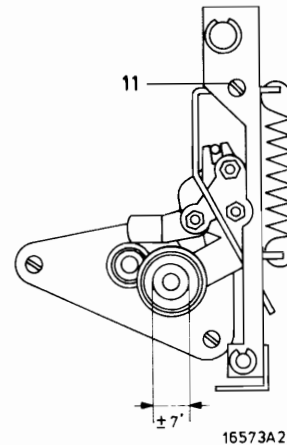

**Remark:**

- The exact height adjustment of the audio/sync. head is effected during the dynamic tape path adjustment.

**Audio/sync. head**

**a. Azimuth adjustment**

- Insert the Service test cassette with premodulated tape (4822 397 60042) into the recorder.
- Connect a milli-voltmeter, via an RC-filter, to point 3 or 5 of BU504 (see Fig. III-25).
- Playback one third of the tape.
- Adjust the audio/sync. head for maximum voltage on point 3 or 5 BU504 by means of nut D.

**b. Height adjustment**

- On the servo panel, close the soldering bridge A and open soldering bridge B (see Fig. III-26).
- Insert the Service test cassette with premodulated tape (4822 397 60042) into the recorder.
- Connect an oscilloscope or milli-voltmeter to test point B33 (see diagram B).
- Playback one third of the tape.
- Using nut F, adjust the height of the audio/sync. head so that minimum interference occurs in both signals on the oscilloscope.
- Open solder bridge A on the servo panel and close solder bridge B.

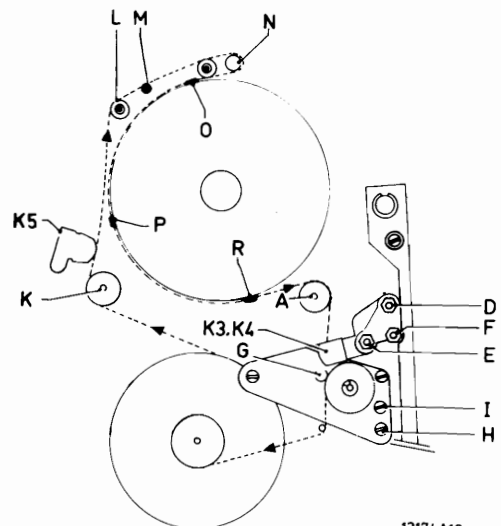

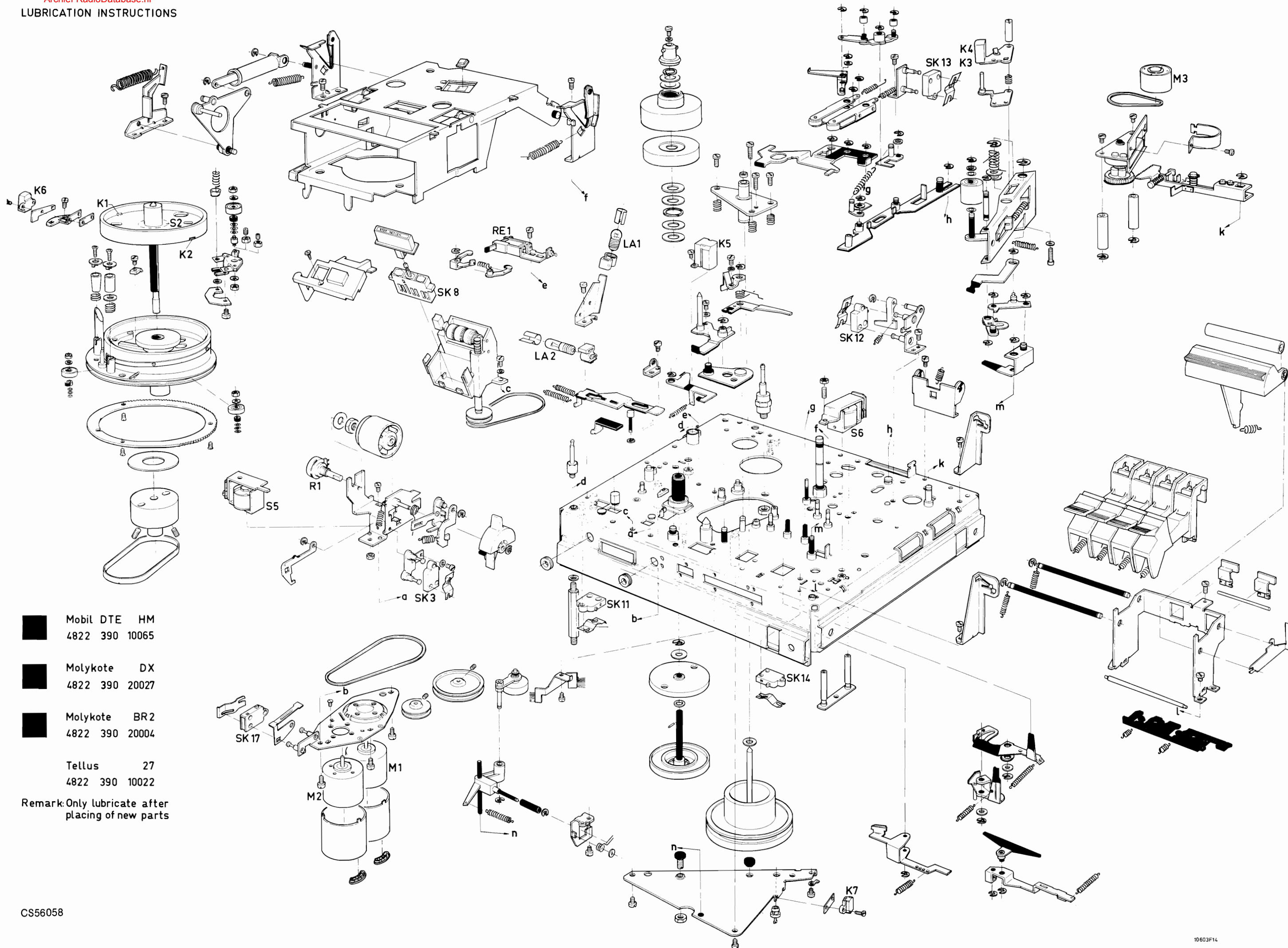

- Mobil DTE HM  
4822 390 10065
- Molykote DX  
4822 390 20027
- Molykote BR2  
4822 390 20004
- Tellus 27  
4822 390 10022

Remark: Only lubricate after placing of new parts

**IV. CIRCUIT AND WIRING DIAGRAMS**

<b>Contents</b>	<b>Page</b>	<b>Date</b>
1. Measuring	IV - 3	76-07-15
2. Explanation of the signs and symbols used in the diagrams	IV - 3	76-07-15
3. Connecting data of the semi-conductors applied	IV - 3	76-07-15
4. Circuit and wiring diagrams		
- Circuit diagram A (signal section)	IV - 4	76-07-15
- Track sides of main PC-boards of the signal section	IV - 5	
- Circuit diagram B (servo section)	IV - 6	
- Track side of servo PC-board	IV - 7	
- Circuit diagram C (supply and control section)	IV - 8	
- Track side of supply PC-board	IV - 9	
- Circuit diagram D (electronic timer)	IV - 10	
- Track and parts side of timer PC-board	IV - 11	
- Survey of supply points	IV - 12	
- Wiring diagram	IV - 13	
	IV - 14	



**1. MEASURING**

Measuring the DC-currents and oscillograms shown in the circuit and PC-board diagrams.

**General**

- Unless otherwise indicated, all voltages were measured with respect to mass with a moving-coil meter with an Ri of 40.000 Ω/V.
- All oscillograms were measured with respect to mass with an oscillograph with an input impedance of 1 MΩ//20 pF via an attenuation probe of 10 MΩ//10 pF.
- All voltages and oscillograms were measured at nominal mains voltage.

**DC-voltages**

Measuring the DC voltages:

*Recording circuits*

- . Insert dummy cassette, so that cassette switch SK17 is closed.
- N.B.: By cassette dummy is understood a cassette without reels
- . Set to recording
- . No aerial signal supplied
- . Set channel selector to VHF

*Playback circuits*

- . No cassette in the recorder
- . Set to playback

**Oscillograms**

Measuring the oscillograms:

*Recording circuits*

- . Insert dummy cassette
- . Set to recording
- . Supply colour bar pattern from generator PM5509 to aerial input.
- Carrier frequency of signal supplied in the VHF range
- Output voltage of pattern generator 10 mV
- . Burst control on pattern generator to nominal
- . Phaft short-circuited (drawer pulled out).
- . Tune the recorder to the signal supplied.

*Playback circuits*

- . Playback of a colour bar pattern from a PM5509 previously recorded on tape.
- . Tracking control optimally adjusted.

**2. EXPLANATION OF THE SYMBOLS USED IN THE DIAGRAM**

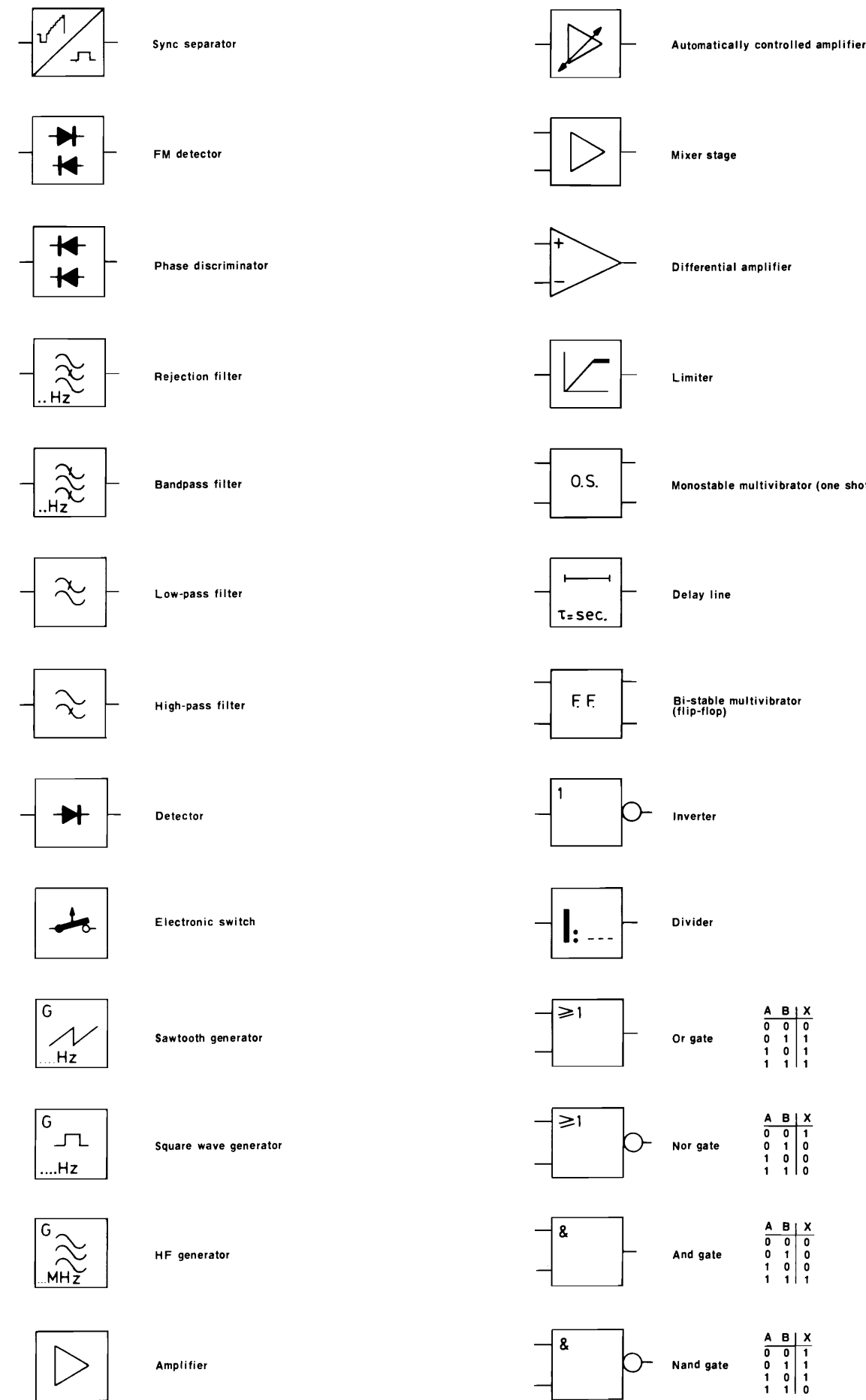

10104C12

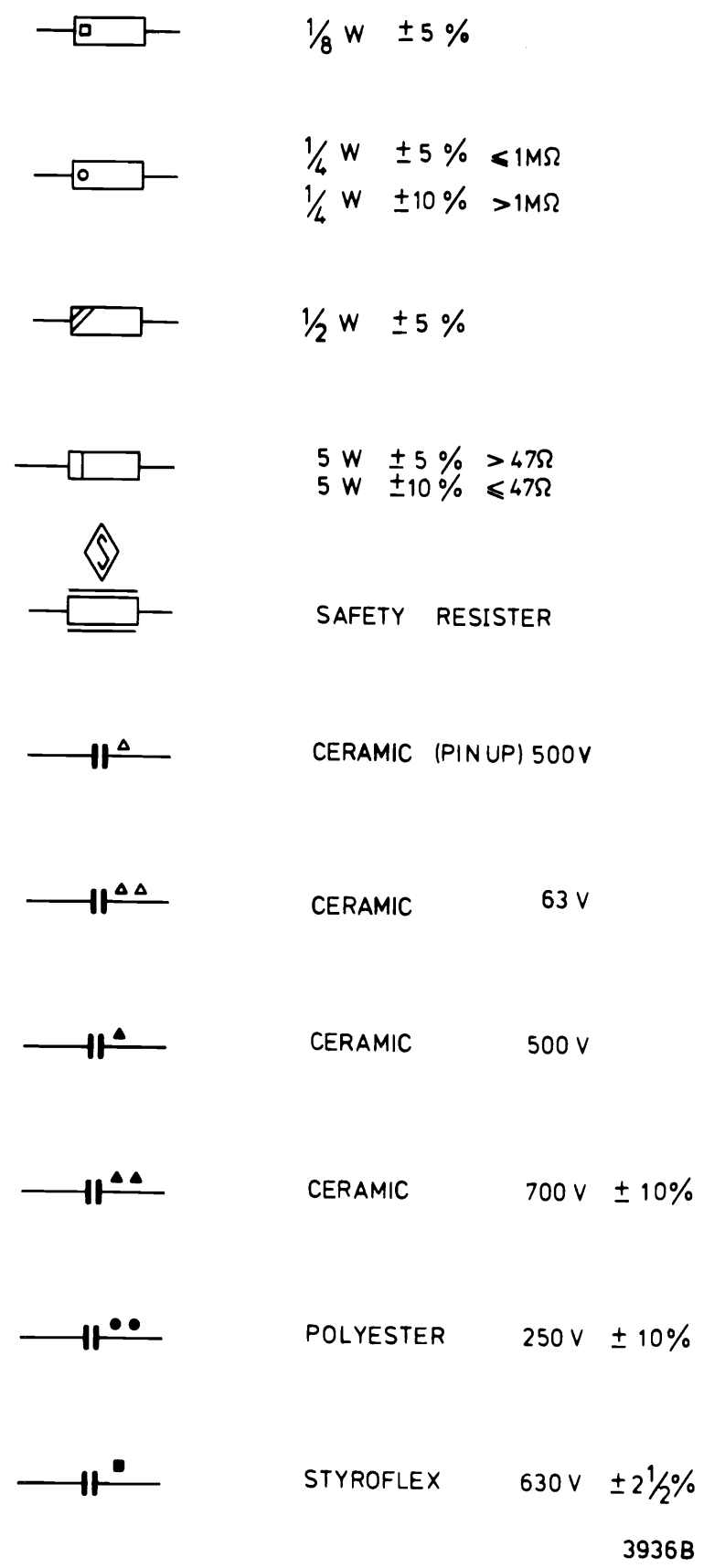

**3. CONNECTING DATA OF THE SEMY-CONDUCTORS USED**

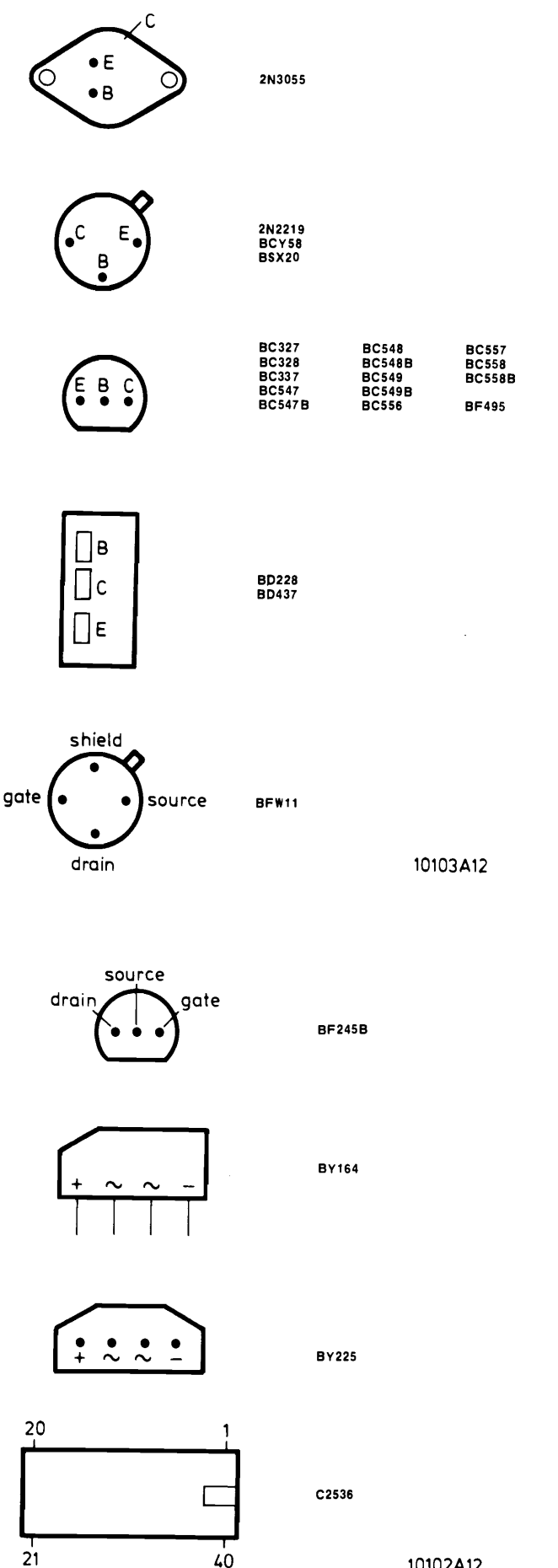

10102A12

CS55652

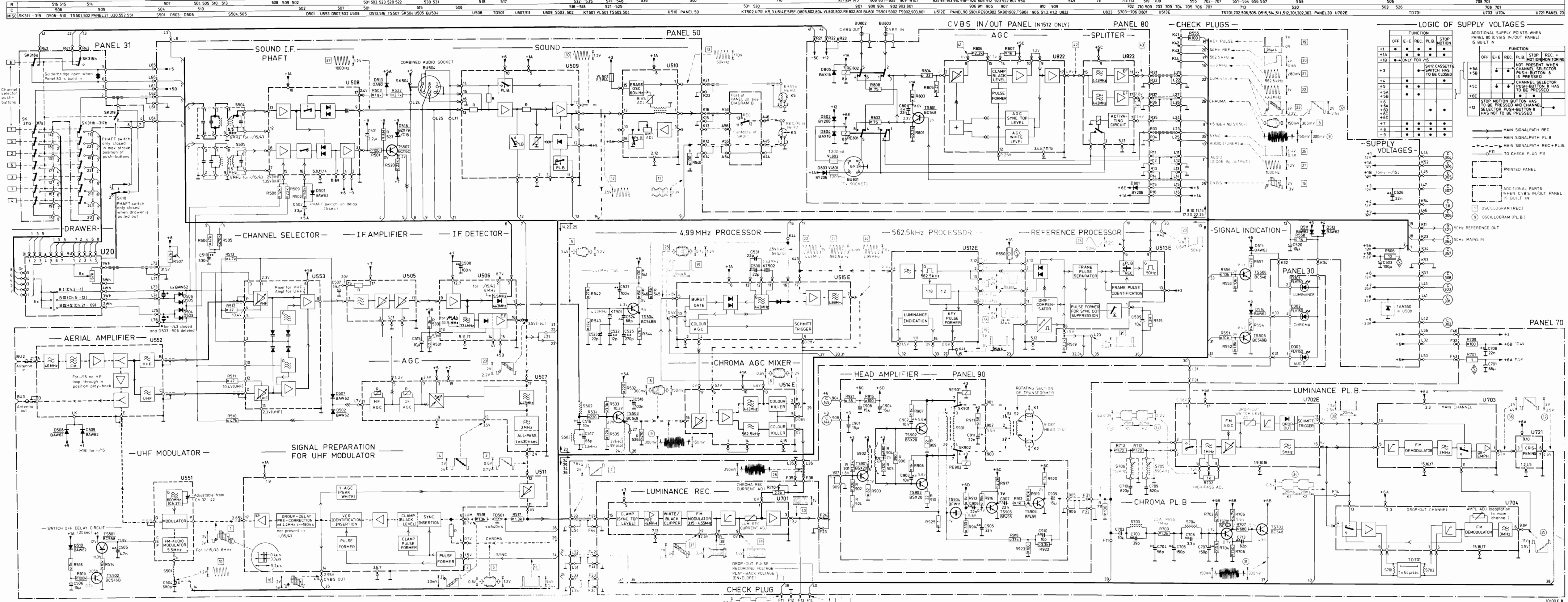







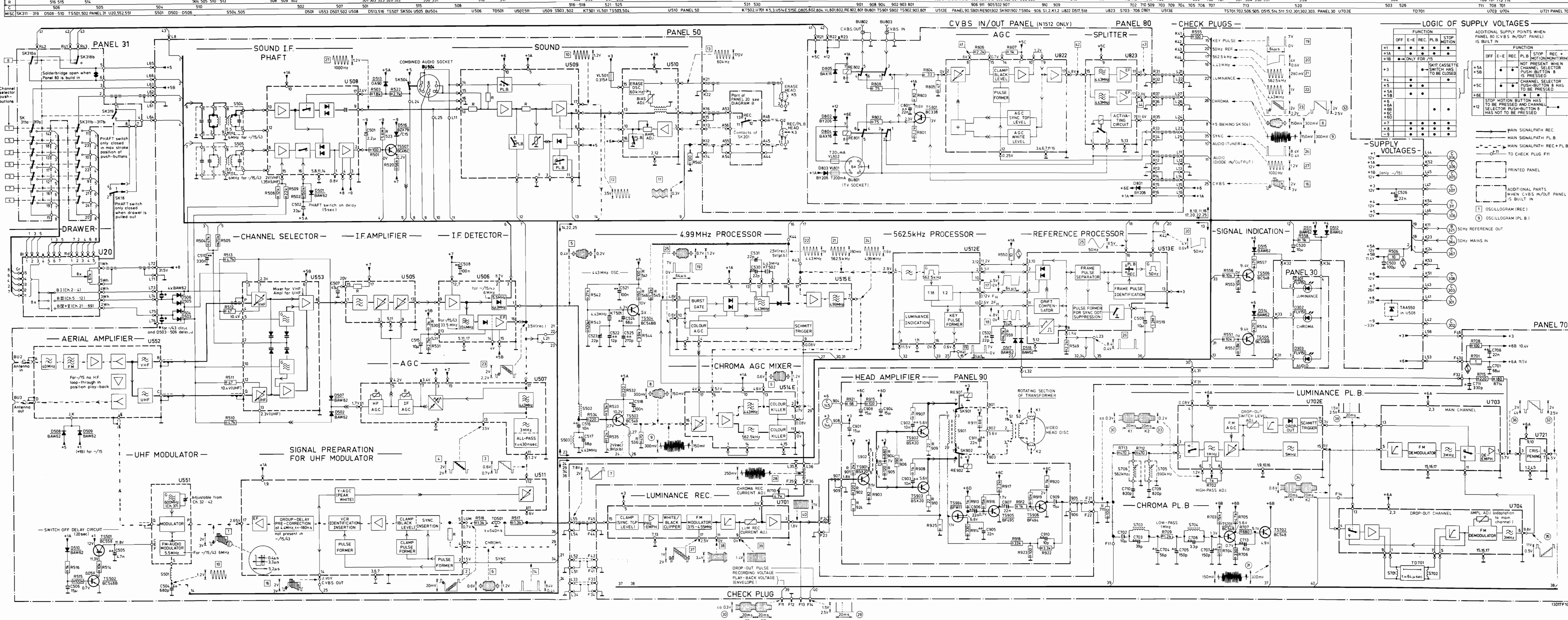

**LOGIC OF SUPPLY VOLTAGES**

FUNCTION	OFF	E-E	REC.	PL.B	STOP	REC.
+1A	•	•	•	•	•	•
+1B	•	•	•	•	•	•
+3	•	•	•	•	•	•
+4	•	•	•	•	•	•
+5	•	•	•	•	•	•
+5A	•	•	•	•	•	•
+5B	•	•	•	•	•	•
+6	•	•	•	•	•	•
+6A	•	•	•	•	•	•
+6B	•	•	•	•	•	•
+6C	•	•	•	•	•	•
+7	•	•	•	•	•	•
+8	•	•	•	•	•	•
+8	•	•	•	•	•	•
+9	•	•	•	•	•	•

ADDITIONAL SUPPLY POINTS WHEN PANEL 80 (CVBS IN/OUT PANEL) IS BUILT IN:

FUNCTION	OFF	E-E	REC.	PL.B	STOP	REC.
+5A	•	•	•	•	•	•
+5C	•	•	•	•	•	•
+6E	•	•	•	•	•	•
+12	•	•	•	•	•	•

LEGEND:  
 — MAIN SIGNALPATH REC.  
 — MAIN SIGNALPATH PL.B  
 - - - TO CHECK PLUG F11  
 [ ] PRINTED PANEL  
 [ ] ADDITIONAL PARTS WHEN CVBS IN/OUT PANEL IS BUILT IN  
 (1) OSCILLOGRAM (REC)  
 (2) OSCILLOGRAM (PL.B)



(ADAPTED TO FACTORYCODE WD11,N1512) WIRING DIAGRAM A

R	505	513	508	509	501	510	511	530	506	531	502	507	503	533	518	517	522	519	544	514	548	515	542	545	550	553	556	551	558	555	554	
C	512	504			520	523	501	503	502		508	518	507	517	505		509	504	526	521	525	506	532					530	520			
TS	507													503																		
MISC.	BUZ	D503	D506	D502	D516	U552	U508	D501	D511	U511	S504	D508	S502	T0501	S501	D517	BU3	KT501	U513	U509	KT502	D514	U515	BU504	VL501	U517	D510	D512	D515	U514	SK504	D511

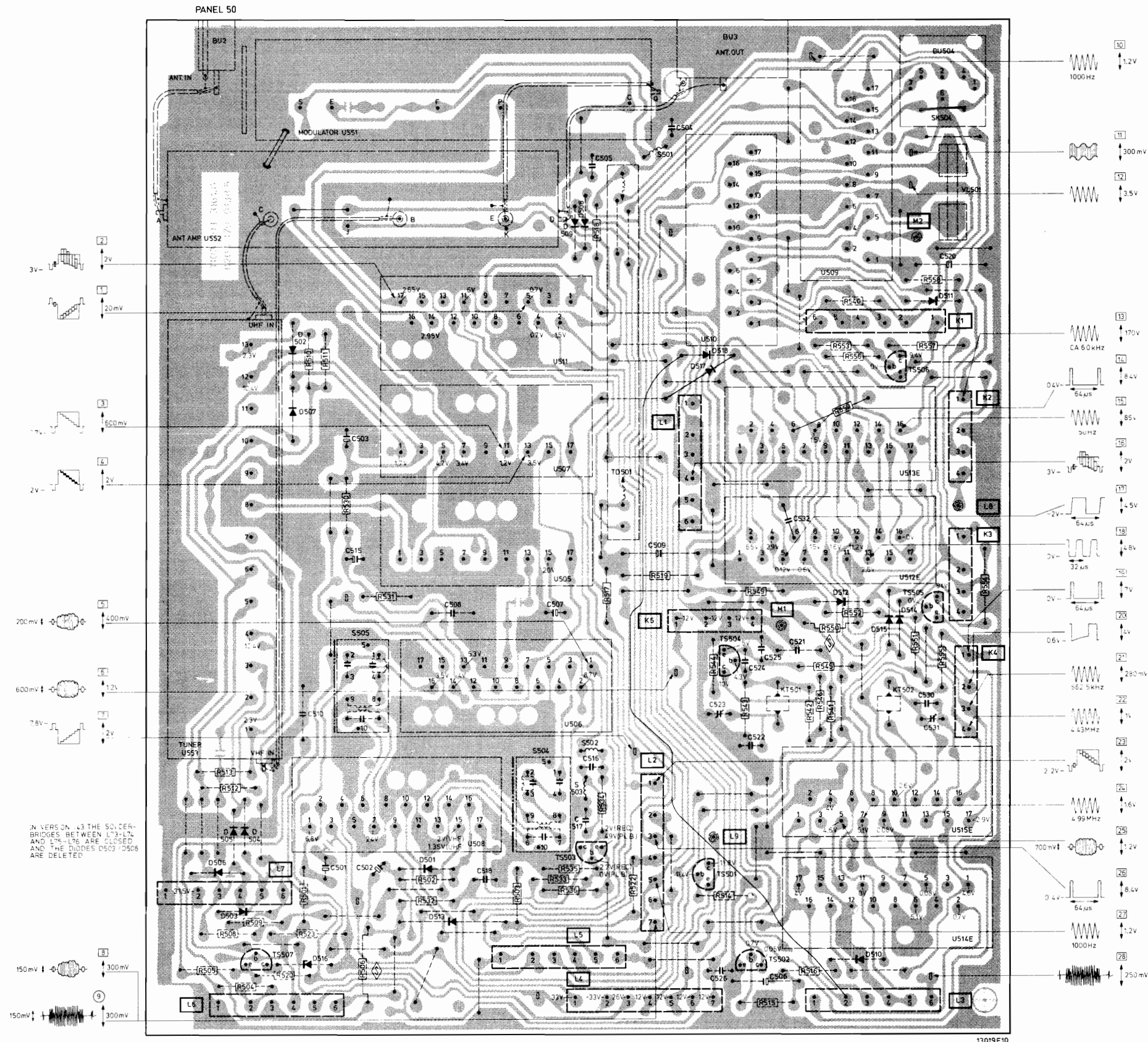

IN VERSION 43 THE SOLDER BRIDGES BETWEEN L73-L74 AND L75-L76 ARE CLOSED AND THE BONES D509 /D508 ARE DELETED

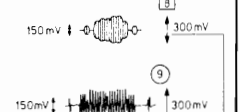

13019E10

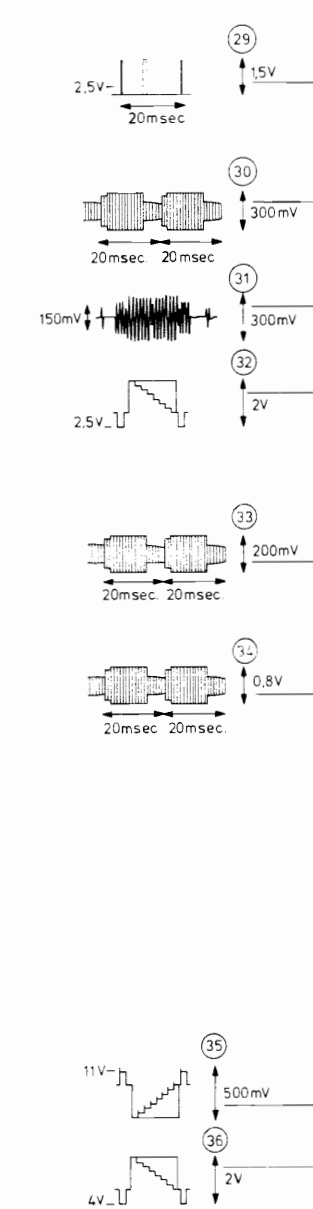

PANEL 70

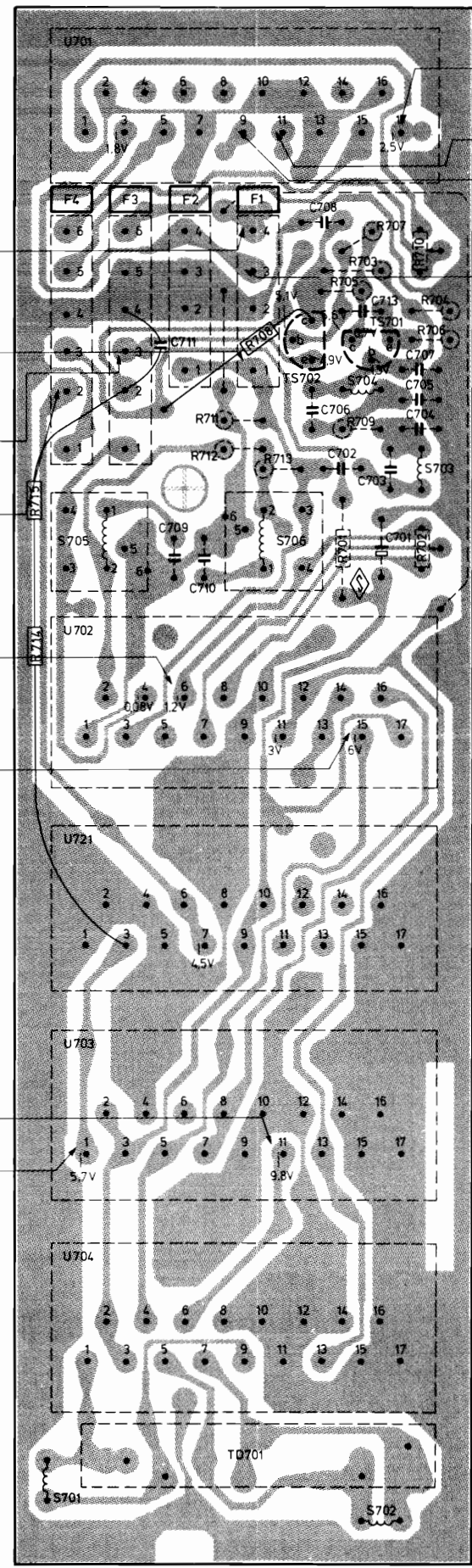

13018D10

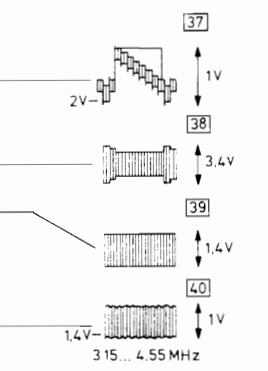

PANEL 80 (N1512 ONLY)

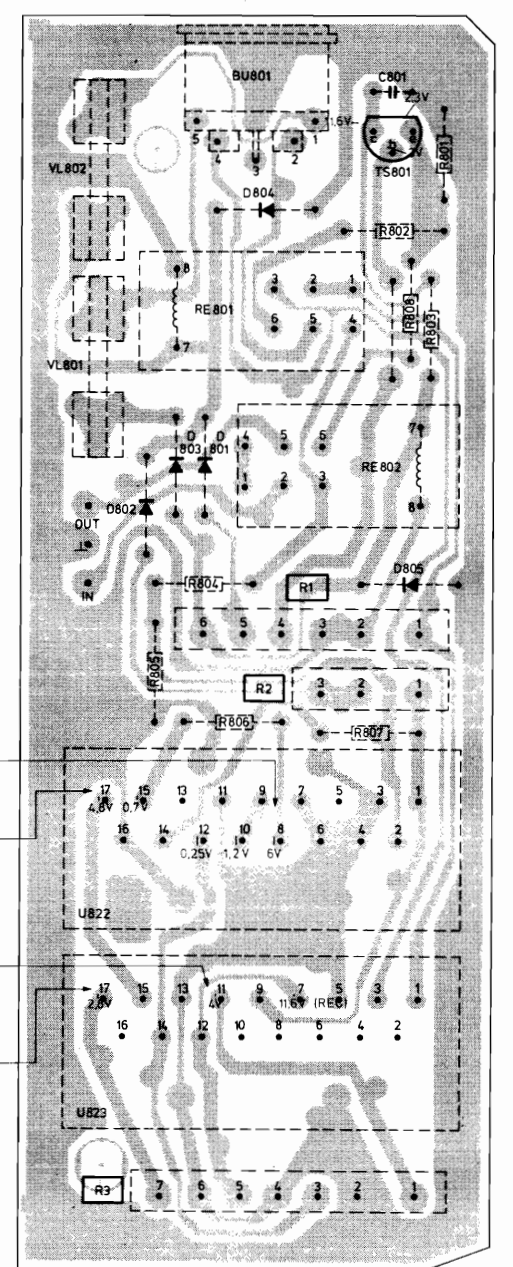

10117D7



CIRCUIT DIAGRAM B

R	201	202 203	204 1	204	205-208	202	203	401-410	401	402
C	201	TS203	U216 U217	SK201 SK202	U218-U220	TS205 TS202 TS201	TS204 S201 S202	S401-S406		
MISC	K4 K7 K6									M1 M2

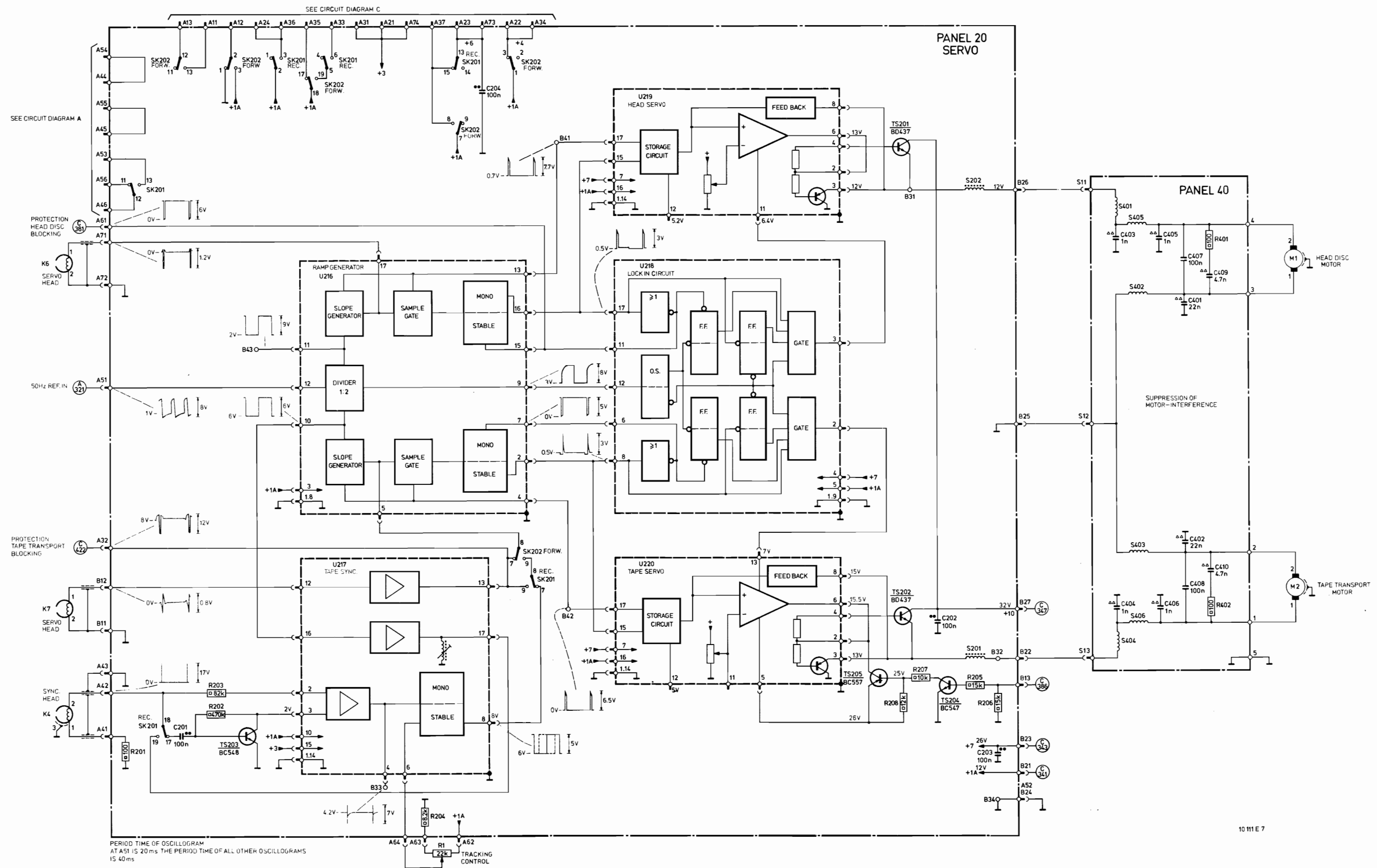



WD-13 for -/00/45  
(ADAPTED TO FACTORYCODE WD-14 for -/15/43/65)

R	505	513	508	501	510	511	530	506	531	502	507	503	533	518	517	522	519	544	514	540	515	542	515	550	553	556	551	558	555	554
C				512	504	520	523			508	518		507	517	505		509	504		526	521	525	508				531		520	
TS	507										503										506						505			
MISC	BU2	D503	D508	D502	D516	D508	D516	D508	D501	D513	U511	U511	U504	D508	D502	D501	D517	BU3	BU3	KT501	U513	U509	KT502	D514	U515	BU504	VL501	U553		

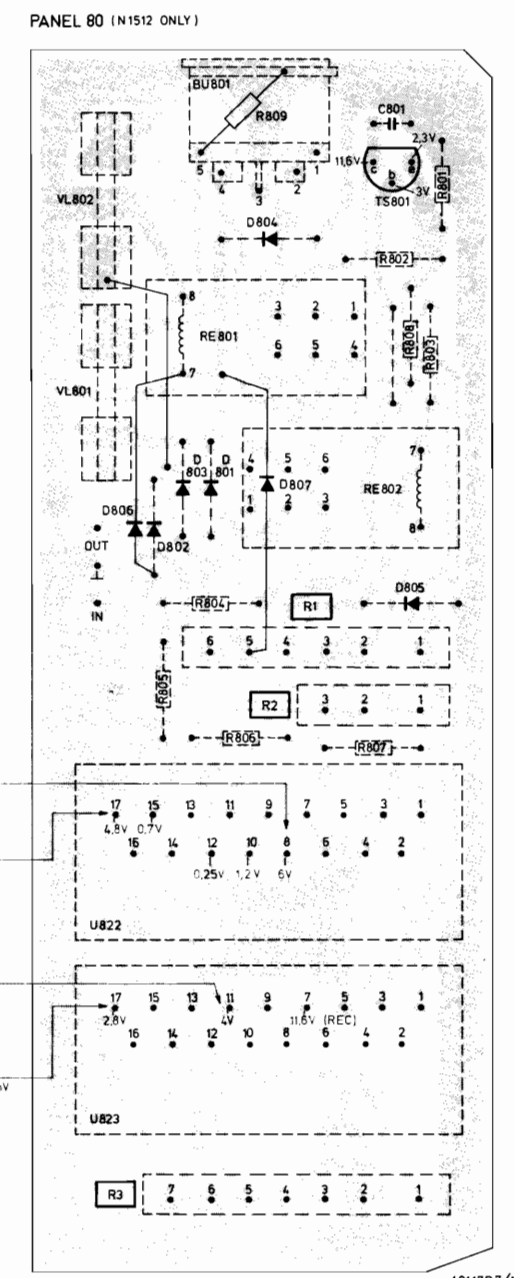
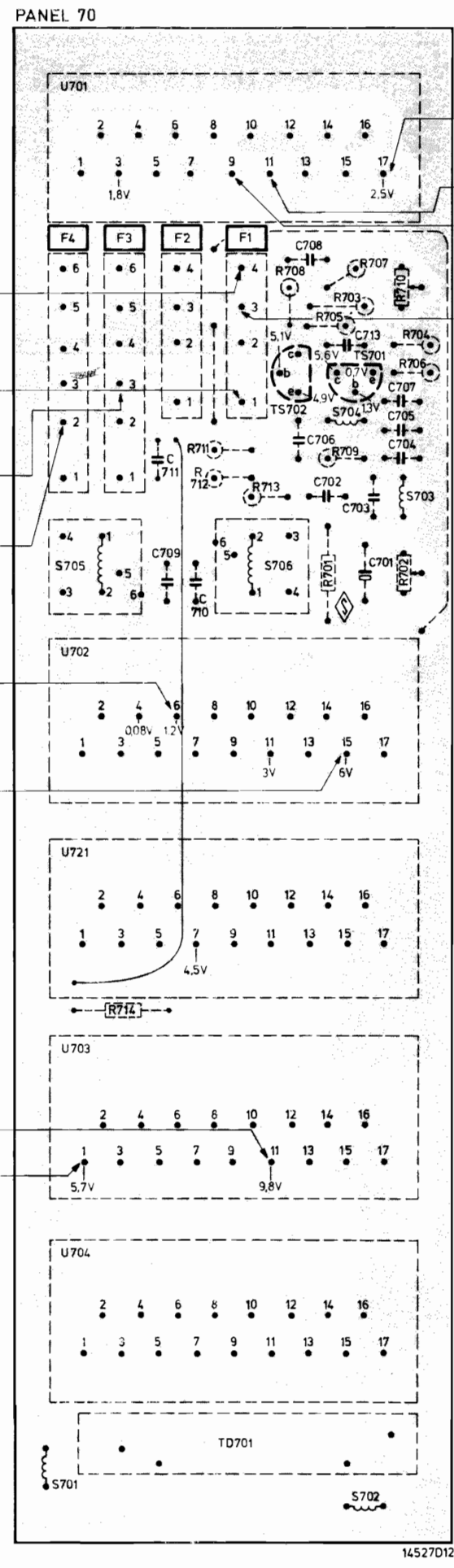
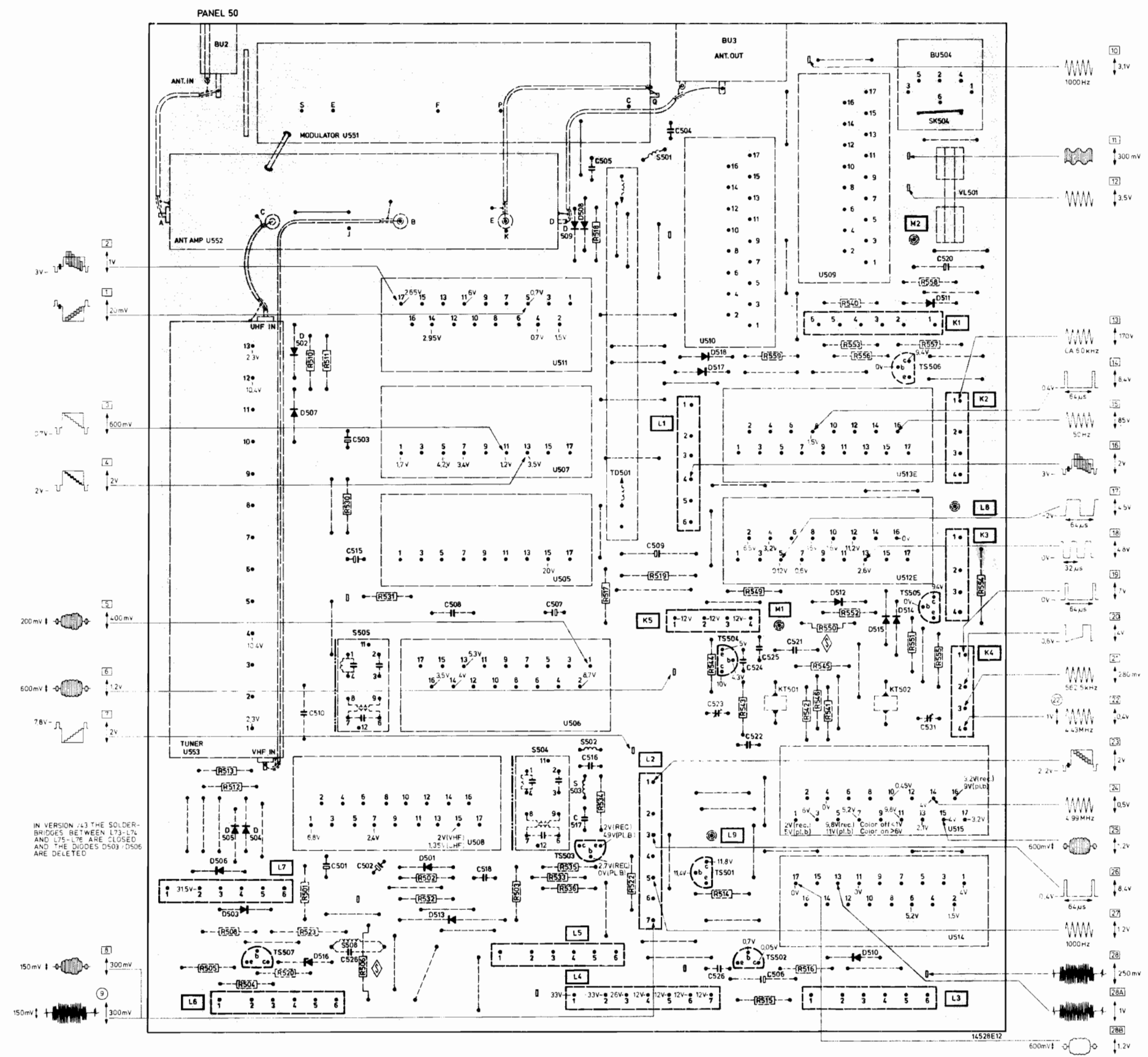

IN VERSION 7/13 THE SOLDER BRIDGES BETWEEN L73-L74 AND L75-L76 ARE CLOSED AND THE DIODES D503 / D506 ARE DELETED

CIRCUIT DIAGRAM B

R	201	202 203	204 1	205-208	203	401	402
C	201	TS203	U216 U217	SK201 SK202	U218-U220	TS205 TS202 TS201 TS204 S201 S202	S401-S406
MISC	K4 K7 K6						M1 M2

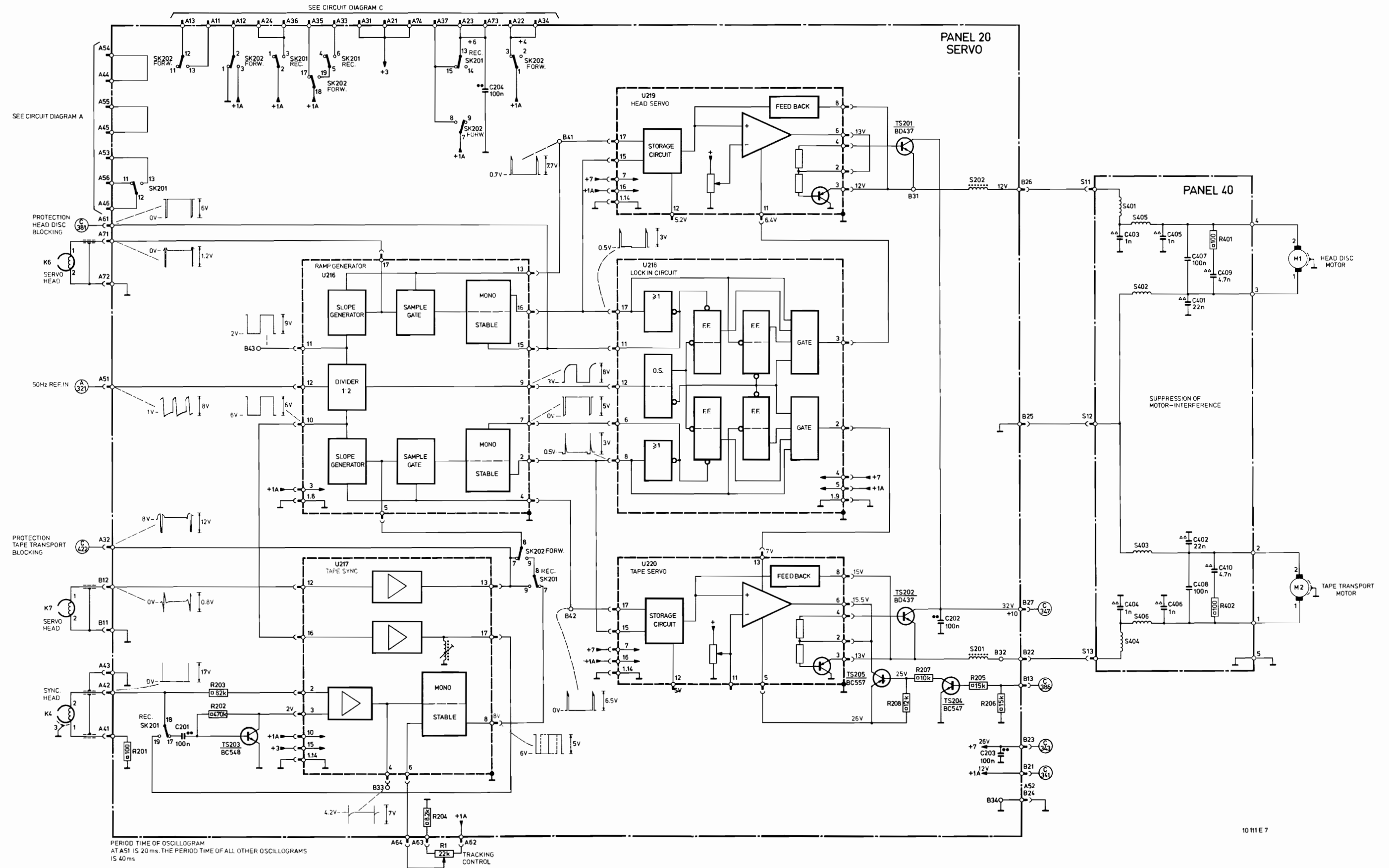



WIRING DIAGRAM B

R	C	TS	MISC
	203		
		201	U219
			S202
206 207			
205 209	202		
		205 204	S201
			U220
	204		
		202	
			U217 U216 U218
	204		
	203		
	202		
	201	203	
	201		SK201 SK202

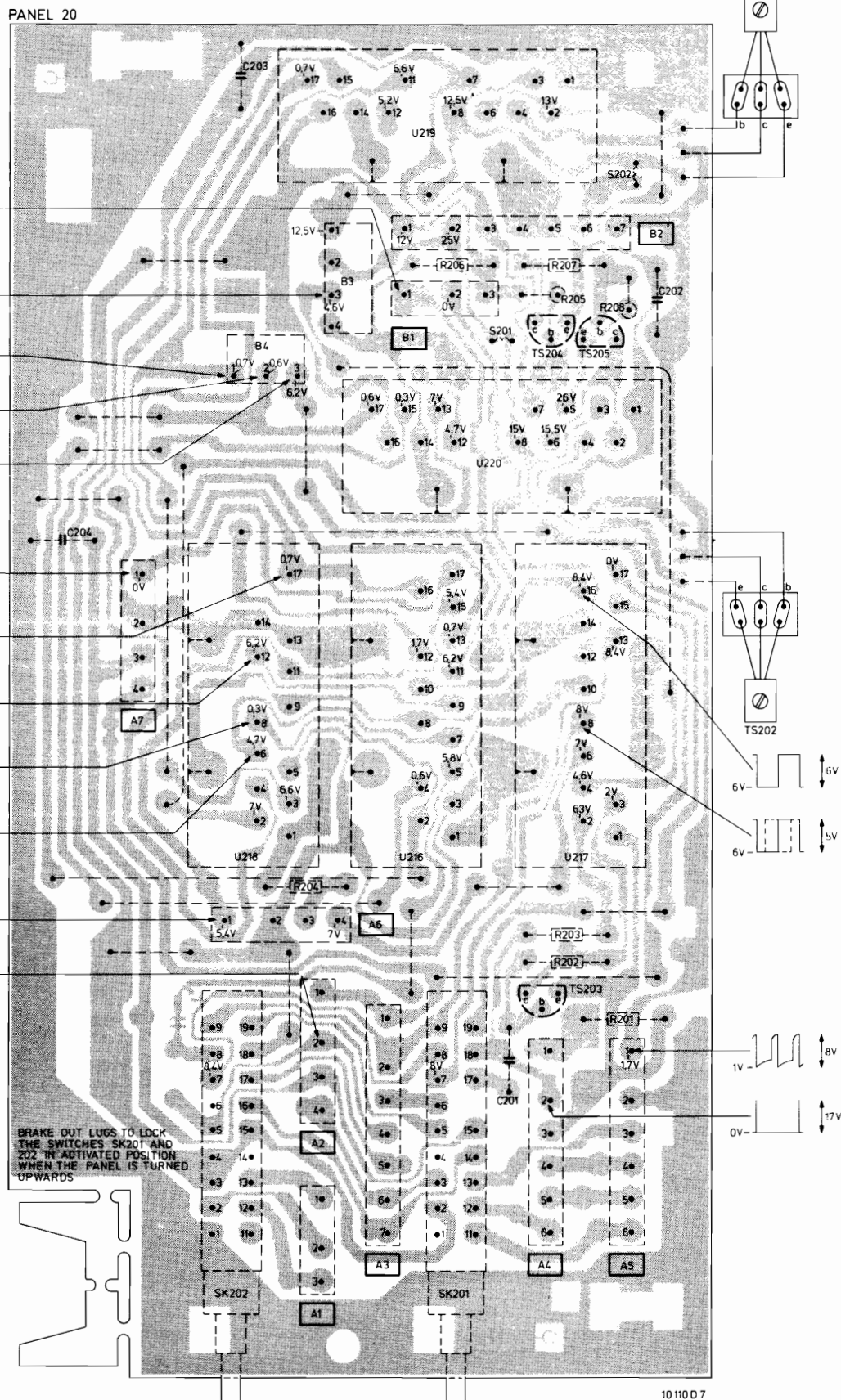

PANEL 40

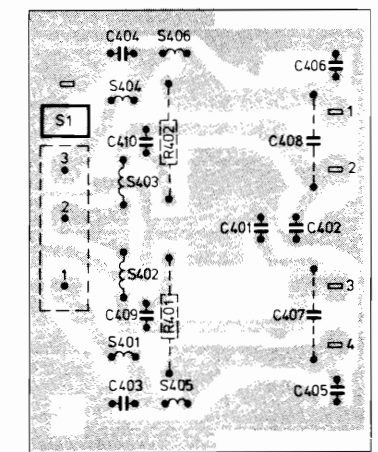

10 115 B 7



CIRCUIT DIAGRAM B (ADAPTED TO FACTORYCODE WD08)

R	201	202 203	215 214 216 1 213 204	205-208 212 211 209 210	401 402
C	201 205	204		202 203	401-410
MISC	K4 K7 K6	TS203	U216 U217	SK201 SK202	U218-U220
				D207, 208, 209	TS205 TS202 TS201, 206 TS204 S201 S202 D201-206
					S401-S406
					M1 M2

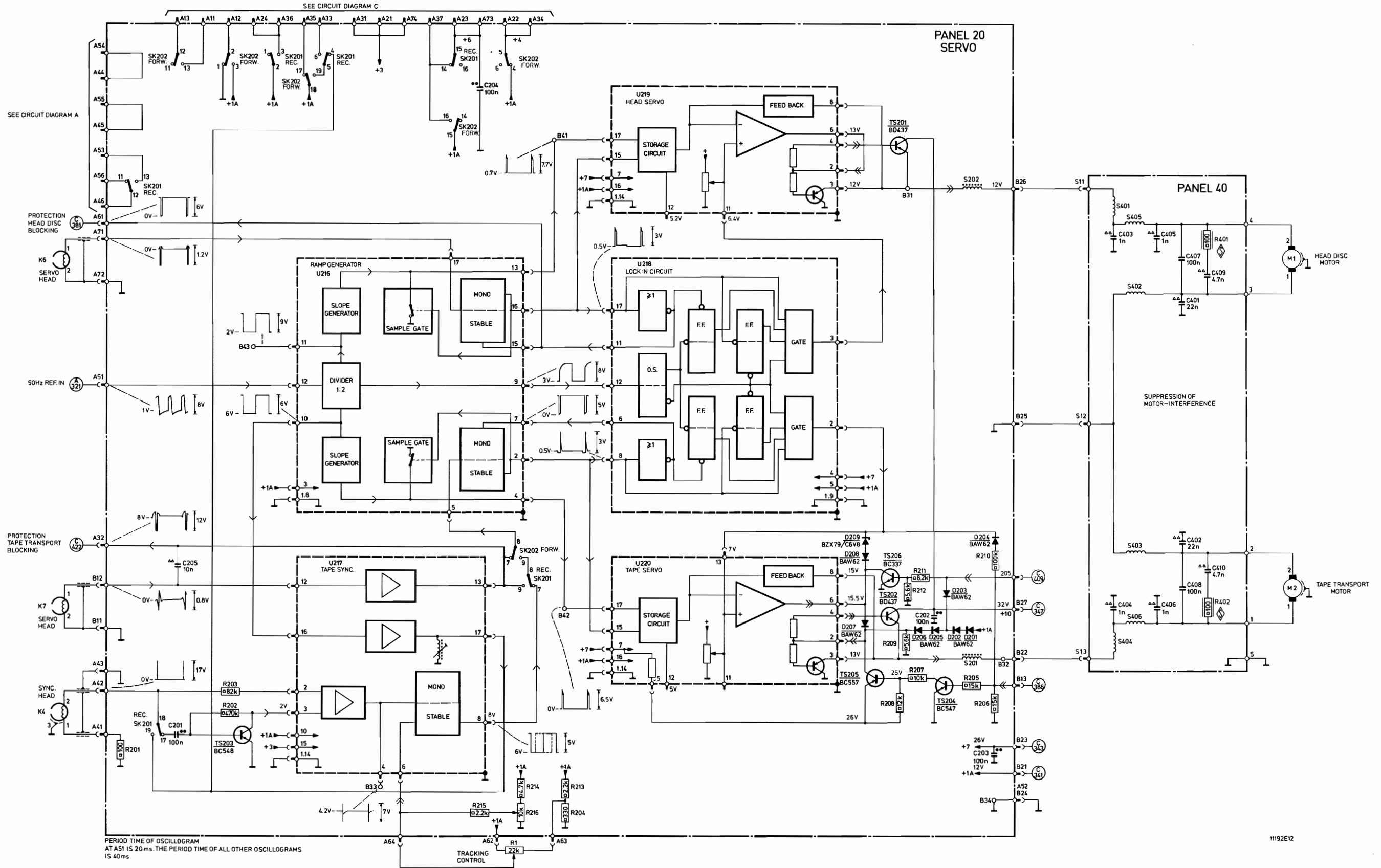

11192E12

WIRING DIAGRAM B

(ADAPTED TO FACTORYCODE WD08)

R	C	TS	MISC
	203		
		201	U219
			S202 D201 D202
210 206 207			D205 D204
209 205 208 211 212	202		D203 D209 D208
		205 204 206	S201 D207
			U220
204			
	205	202	
			U217 U216 U218
213 204			
215 214 216 203			
202			
	203		
201			
			SK201 SK202

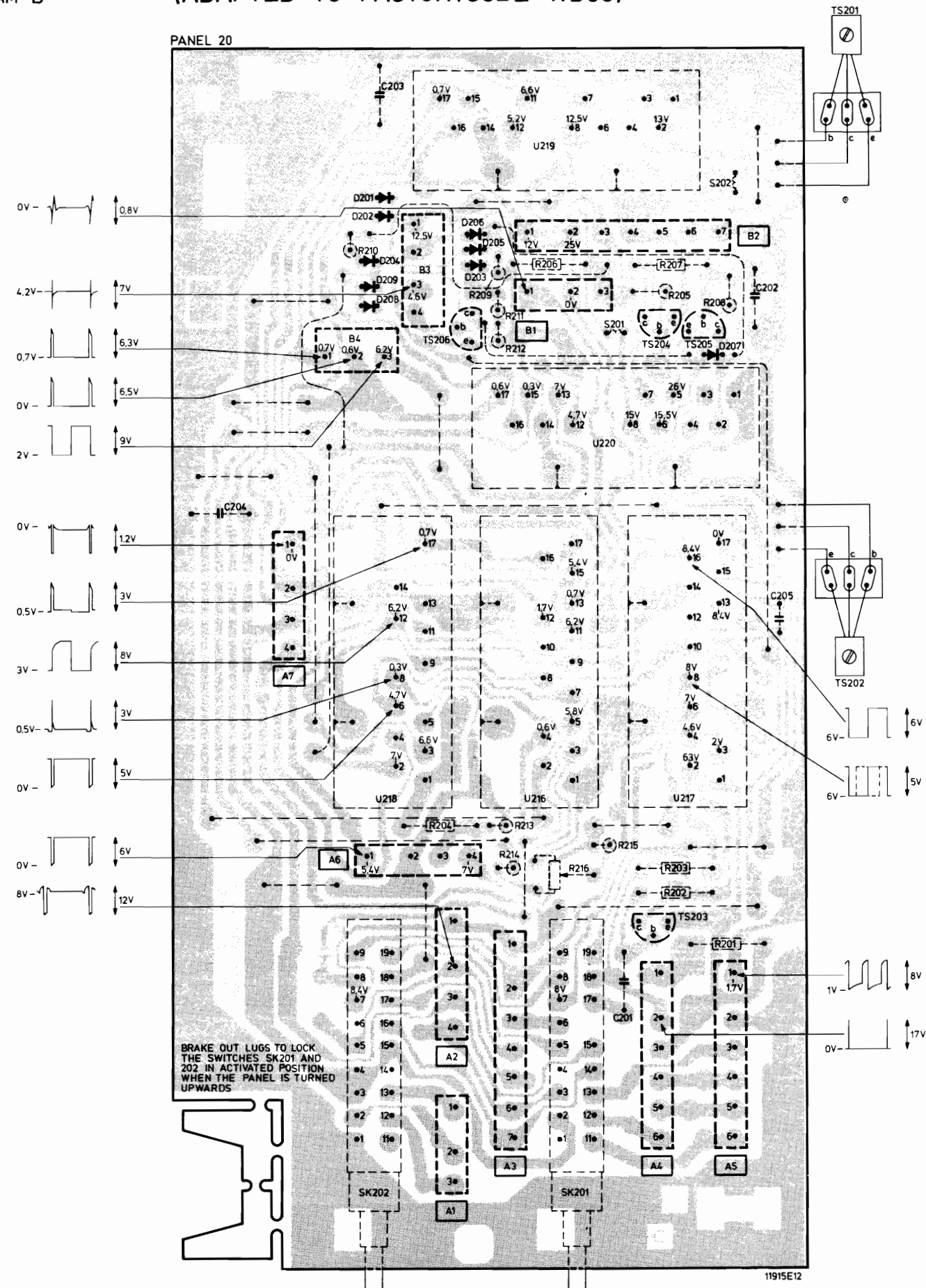

PANEL 40

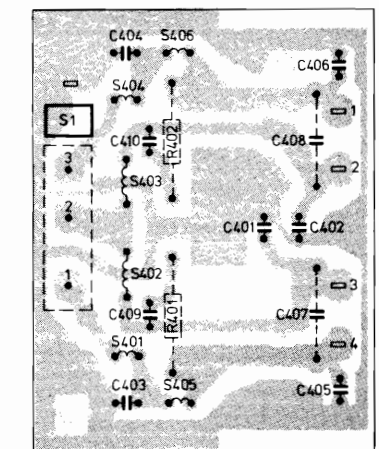



CIRCUIT DIAGRAM B (ADAPTED TO FACTORYCODE WD10)

R	201	202 203	215 214 216 1 213 204	217 212	211 208 207	205 206	401 402
C	201 205	TS203	204	203 202	203 202	401-410	
MISC	K4 K7 K6	U216 U227	S203	SK202 SK201	U219 U228 U221	D207-209 TS206 TS207 TS201,205 D206,205 S202 D201-203 TS202,204 S201	S401- S406

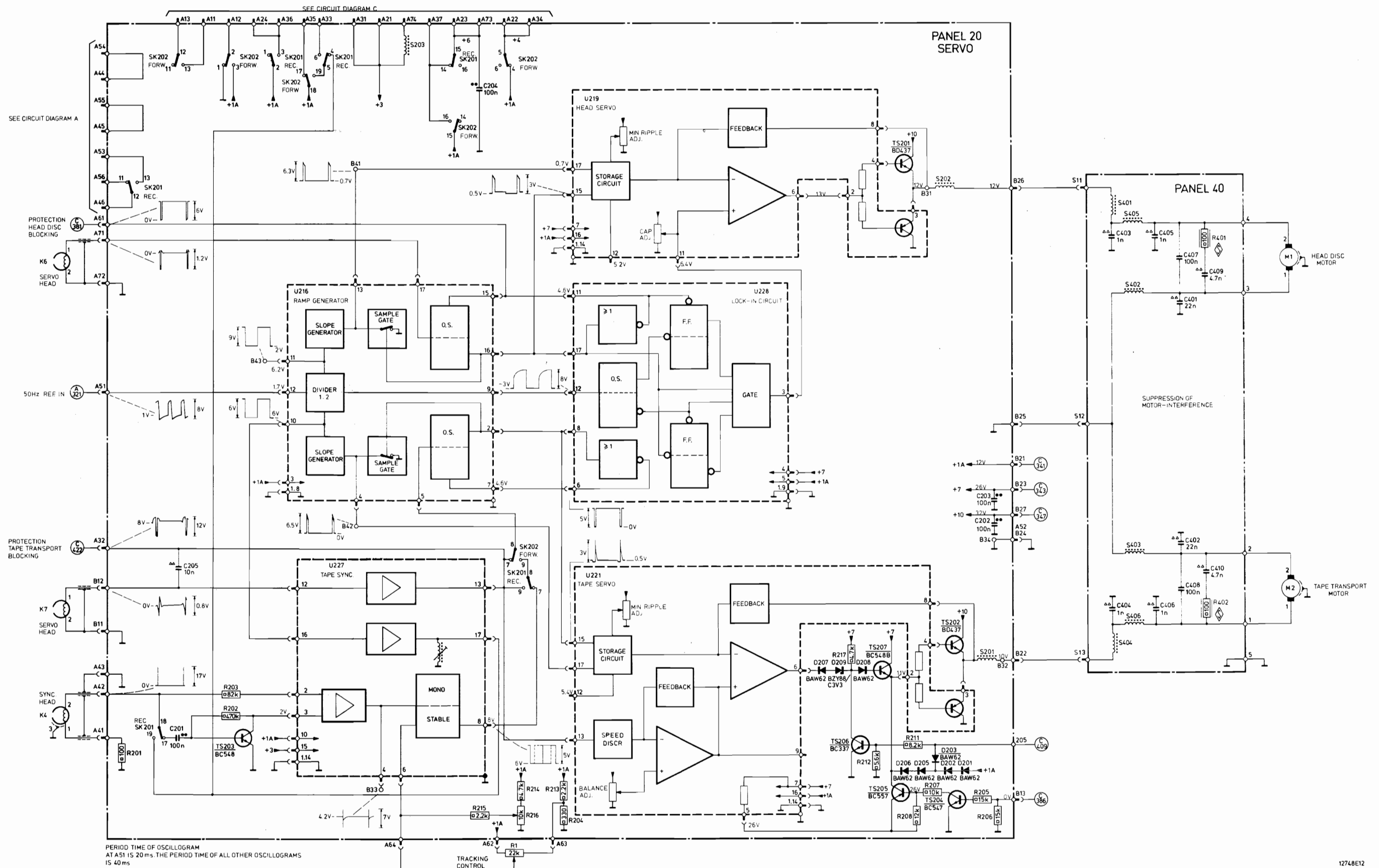



WIRING DIAGRAM B

R	C	TS	MISC
		201	
	203		U219 S202 D201 D202
207 206 217		207	D206 D208 D205 D203
205 208 211	202		D209 D207
212		206 204 205	S201
			U221
	204		
		202	U228 U216 U227 S202
204 213 215			
216 203 202		203	
	201		
		201	SK202 SK201

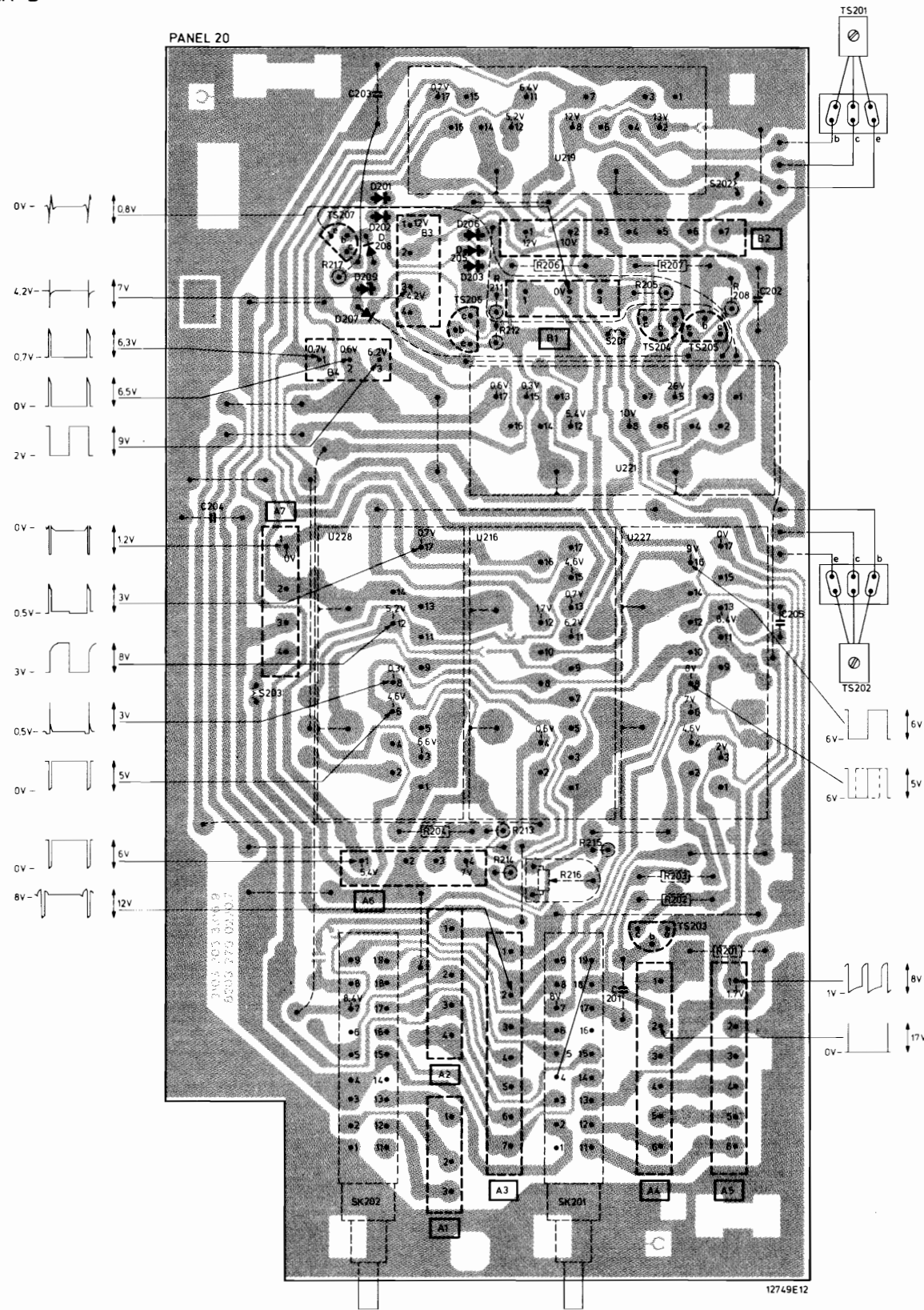

PANEL 40

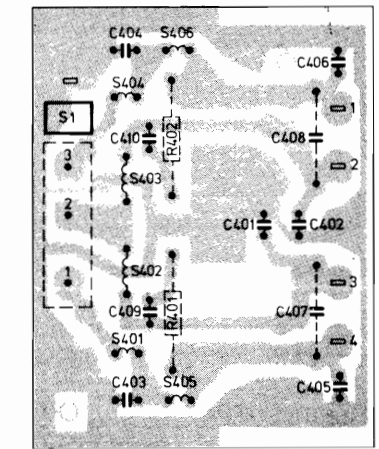

10 115 B7

CIRCUIT DIAGRAM C

MISC	VL1 T1	VL102.101	D101-103	D107.108	D104.105	TS1.101.102.103	D106	TS104	TS105	SK17	SK8	RE 8	LA1	LA2	RE102	D112.115	TS126	D116.113.130.114.128	TS117	D132.133.119	D134	TS115	TS121	D124	TS114.116	M3	SK16	MISC.		
MISC			D109.110	TS108.123.106.107.125	D127	TS124					SK12.13.3.11.14				D111.129.117	TS110	D118	RE101	TS111.109	D121	TS112	TS118	D120	TS119	D131	TS120	TS113	D122.123	SS5.3	MISC.
C101-133		133 132	108 101a.b	102a.b	110 107 109		111 103	104 106							130 112	131 113 118	117.128.114 119	115		116 134	120	125 127 121 123	126 124 122						C101-133	
R101-120			117.115	101-103	105.104.119.118.110		106.107.108.116.109	111 114 113.112.120																						R101-120
R121-140			123 122	124	125		125	121							130 138	139 131.126.140.127.137.132.133-135	136 128 129					123							R121-140	
R141-173			162	169	168	167	170 171								172 173	141	156 144 143 145 146	147.151.157.142.152.148.163.154.149.153.158-160.150.155.161									R141-173			

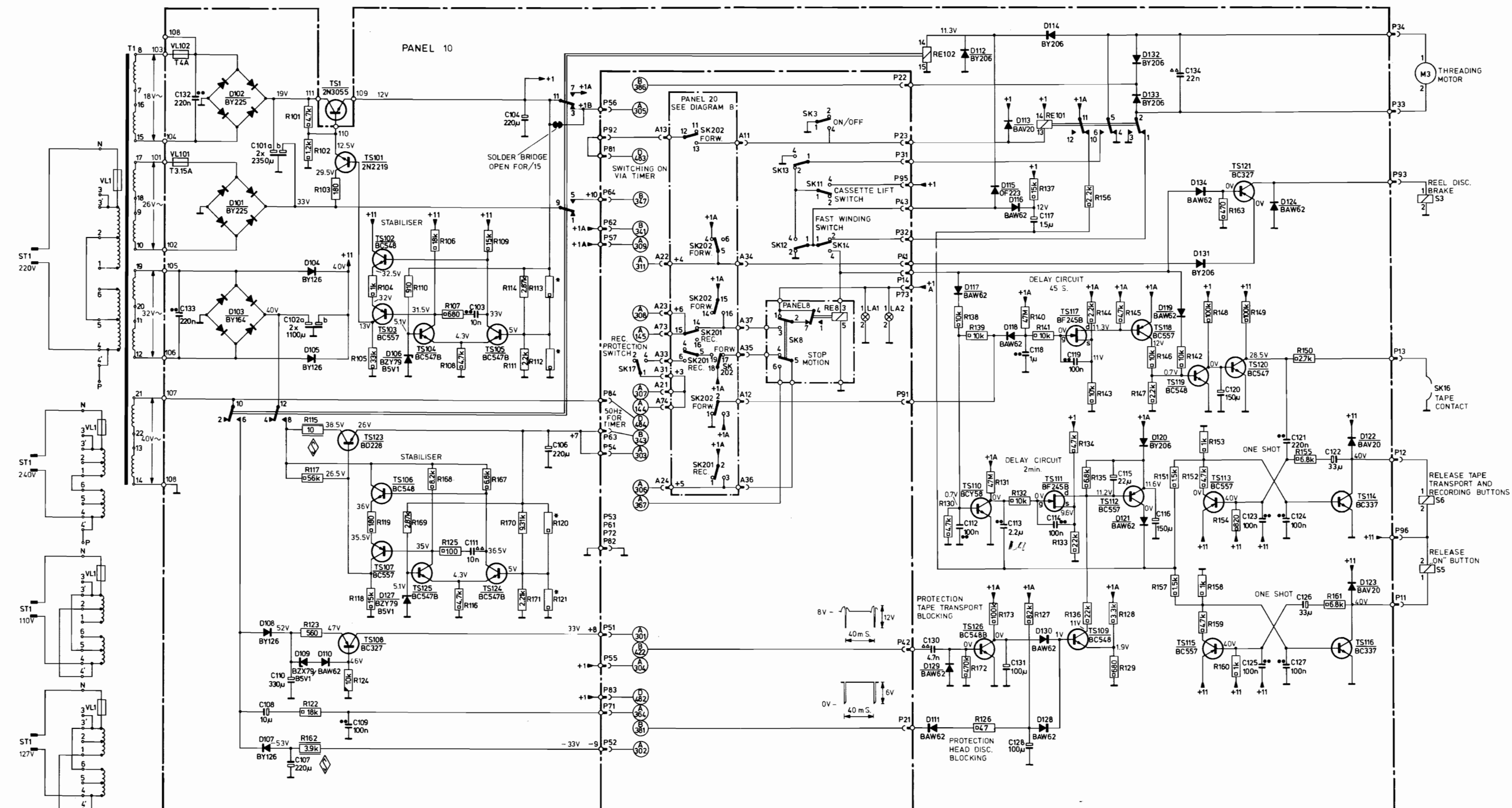

\* RESISTOR MUST BE SELECTED SEE ADJUSTING PROCEDURE

8534E7 A



WIRING DIAGRAM C

R	143 129 ... 133 144 135 145 153 152 147 161 154 160 134 156 ... 158 172 163 101 ... 103 162 124 123 167 110 ... 117 104 ... 109 169 ... 171 118
	138 139 136 150 127 128 146 173 155 151 148 149 100 122
C	118 112 114 ... 116 124 113 120 ... 123 127 131 125 130 117 134 108 109 132 104 111 103 106 124 102 107 105 103 123 106 101 133 110 107 119 128 126
TS	110 109 111 117 112 118 114 113 119 115 126 101 121 108 106 124 102 107 105 103 123
MISC.	D118 D117 D128 D120 D121 D119 D123 D111 D129 ... D134 RE 101 D114 VL102 D110 D112 D107 ... D109 D101 D106 D127 D103 D105 D104 D122 D113 D116 D124 D115 D102 RE102 VL101

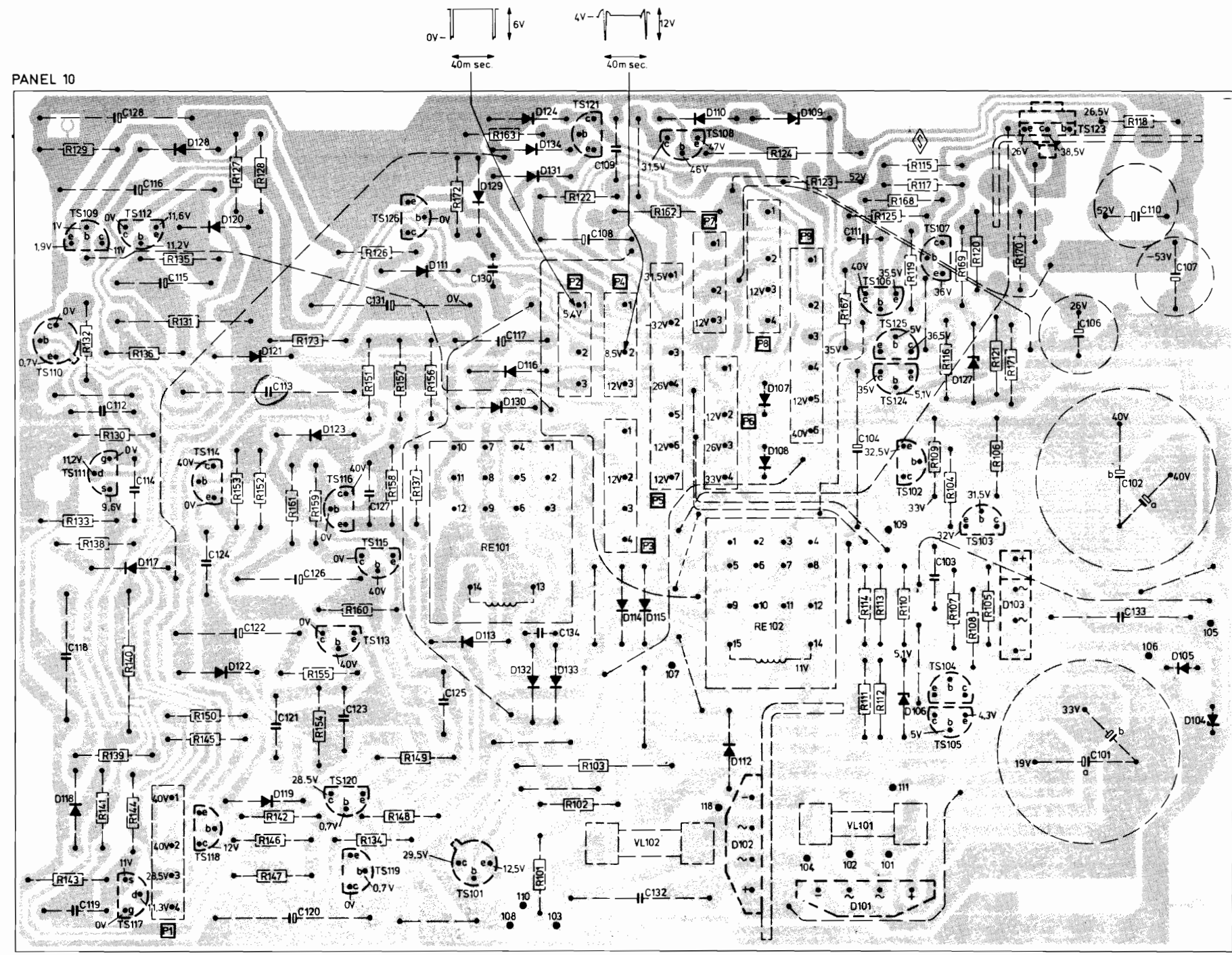



CIRCUIT DIAGRAM C (ADAPTED TO FACTORYCODE WD08)

MISC.	VL1 T1	VL102.101.103	D101...103	D107.108	D104.105	TS1.101.102.103	D106	TS104	TS105	SK17	SK8	RE 8	LA1.SK9.LA2.SK10.RE102	D112.115	TS126	D116.113.130.114.128	TS117	D133.119	D134	TS115	TS122	TS121	TS114.116	M3	SK16	MISC.	
C101...133		133 132	108 101a.b	102a.b	110 107 109			111 103	104	106		SK12.13.3.11.14		130 112	131 113 118	117.128.114 119	115		116 134	120	125 127 121 123	126 124 122 125		RE1	SS.6	MISC.	
R101...120			117.115	101...103	105.104.119.118.110			106.107.108.116.109	111	114 113.112.120				130 138	139	131.126.140.127.137.132.133...135	136 128 129				123						R101...120
R121...140			123	122	124			125		121																	R121...140
R141...177		177	162		169	168		167	170	171				176 172	173 174	141	156.144.143.145.146.166.147.175.151.165.157.142.152.14.8.163.154.14.9.153.164.158-160.150.155.161										R141...173

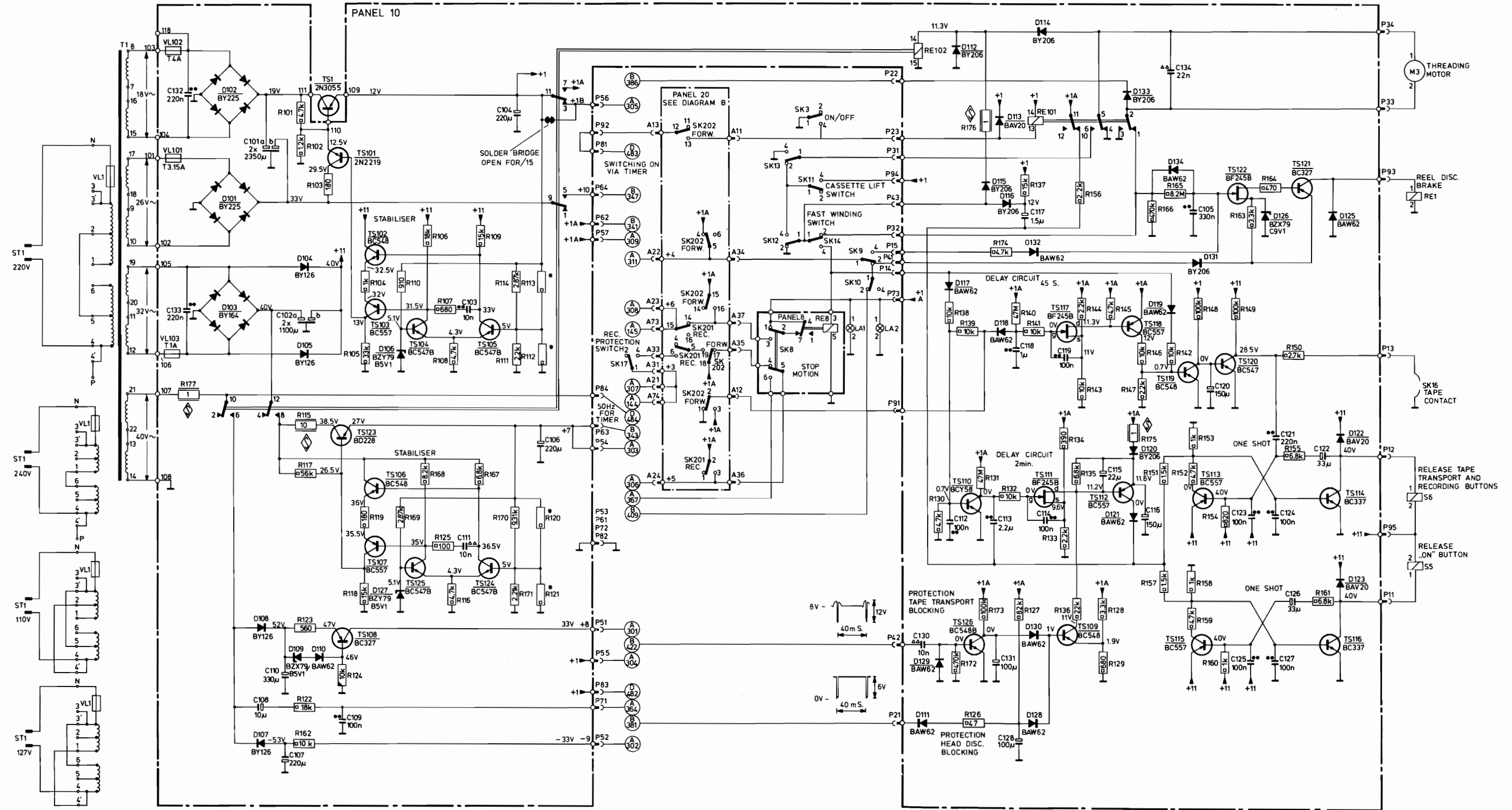

\* RESISTOR MUST BE SELECTED SEE ADJUSTING PROCEDURE

11191E12







IV-10a, N1502,N1512

CIRCUIT DIAGRAM D

R	321 344-351	354 353	337-339	359-364	327-329	352	341	340 335 358	323-326	343	336	330-334	342	357	355 356	322			
C	321-326						328	327											
MISC	TS321	TS326 D332 D333	TS327	D327	D326	TS330-TS333	TS325	D322 SK321-SK326	D334 D323	TS322	IC321	D328 D324 D329	TS324 D331	TS328	D325	TS329	D335 D336	TS323	D321

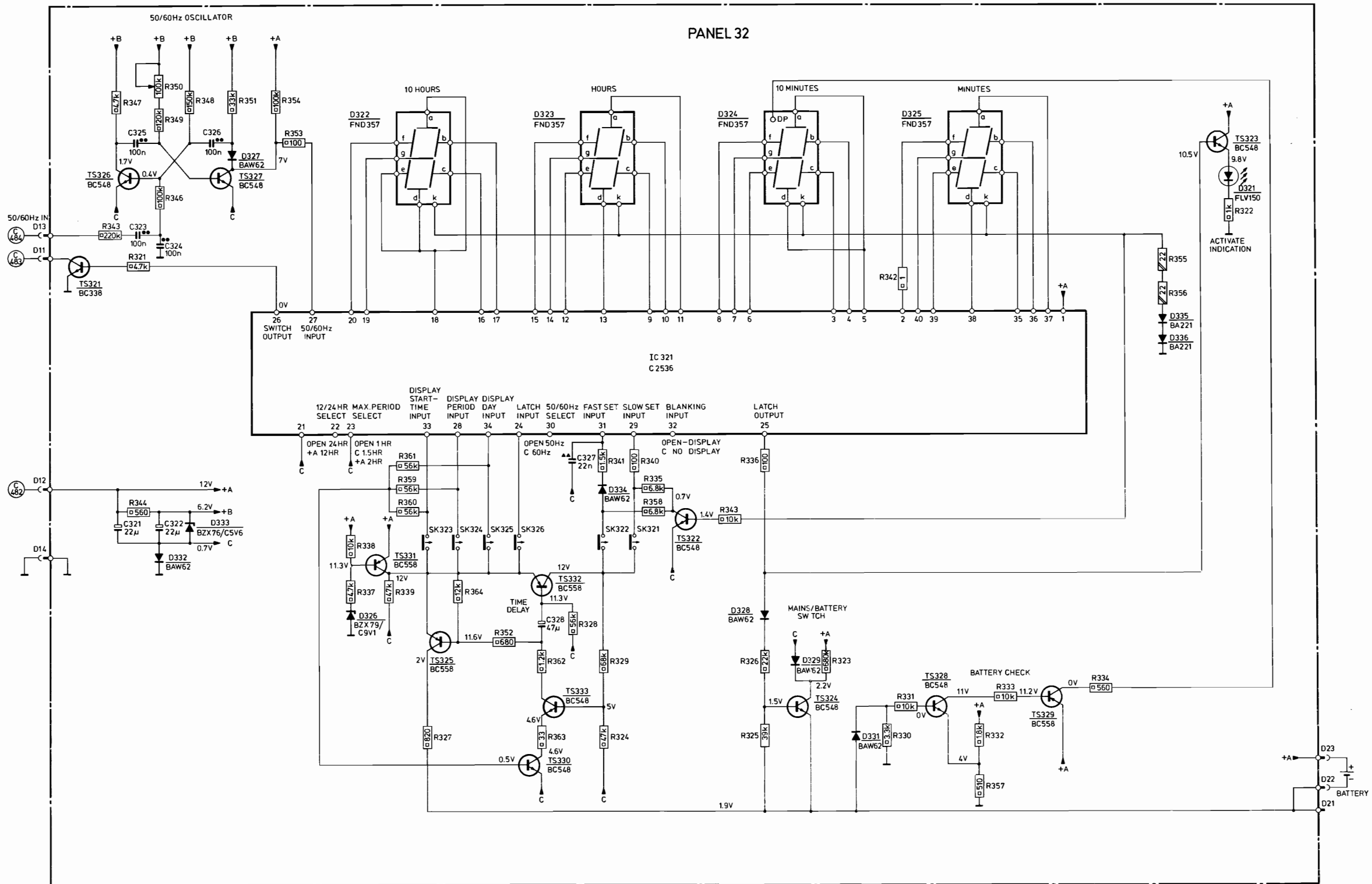

8989E A



WIRING DIAGRAM D

PANEL 32

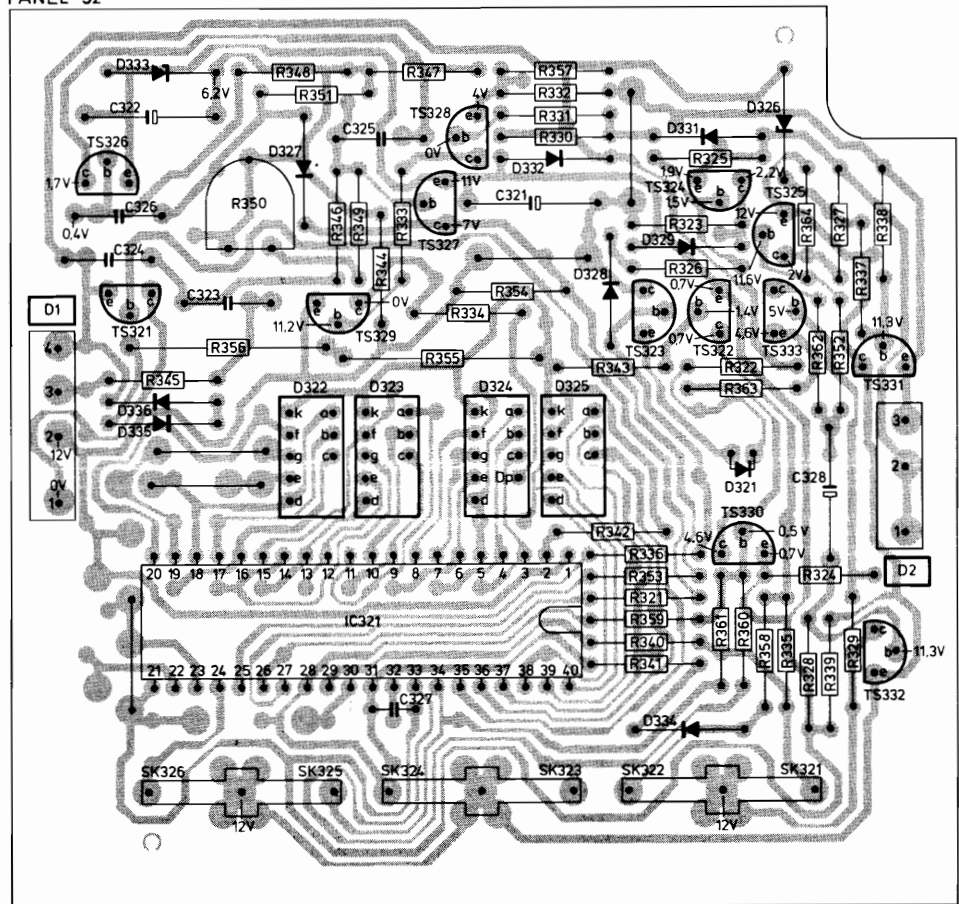

10113 D7

R	337	339	352	360	364	325	321	323	336	340	343	357	354	334	347	333	349	348	350	356	345			
C	328				321				325				323				322				326			
TS	331	332	325	330	324	323	328				327	329				321				326				
MISC.	D326		D321	D331	D329	D328	D332	D325	D323	IC321	D322	D327	D333	D335	D336	SK321	D334	SK322	SK323	SK324	SK325	SK326		

PANEL 32

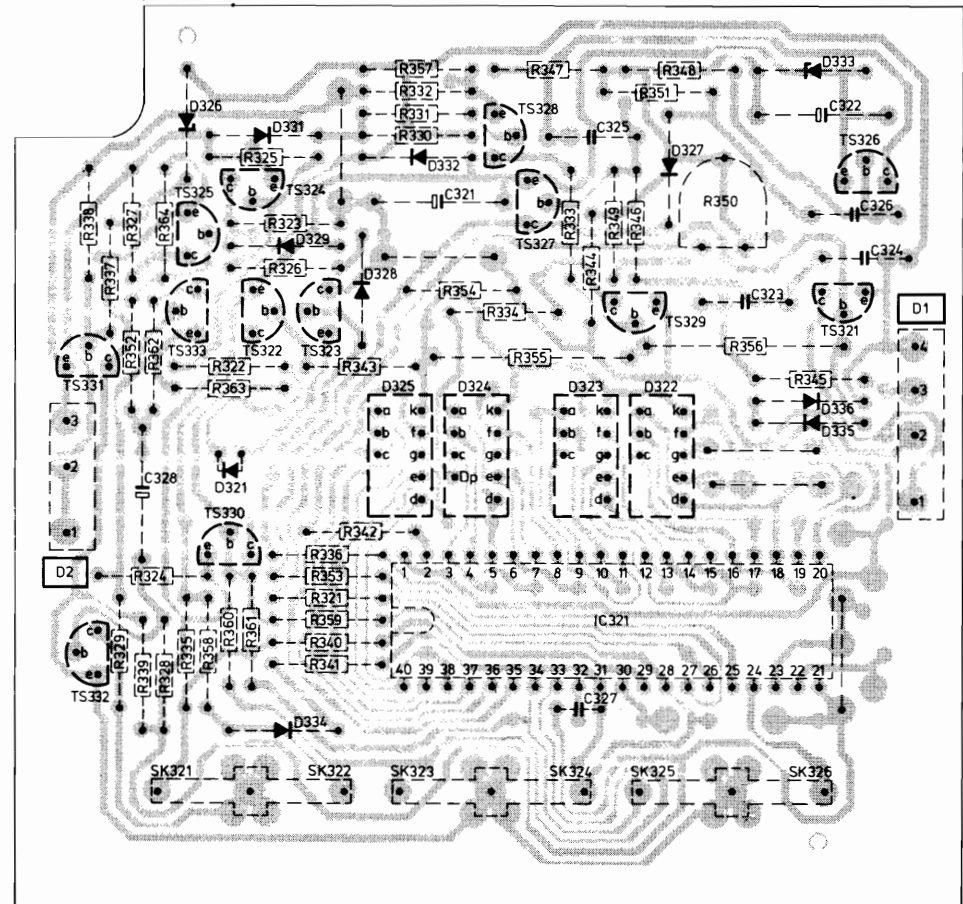

10114 D7

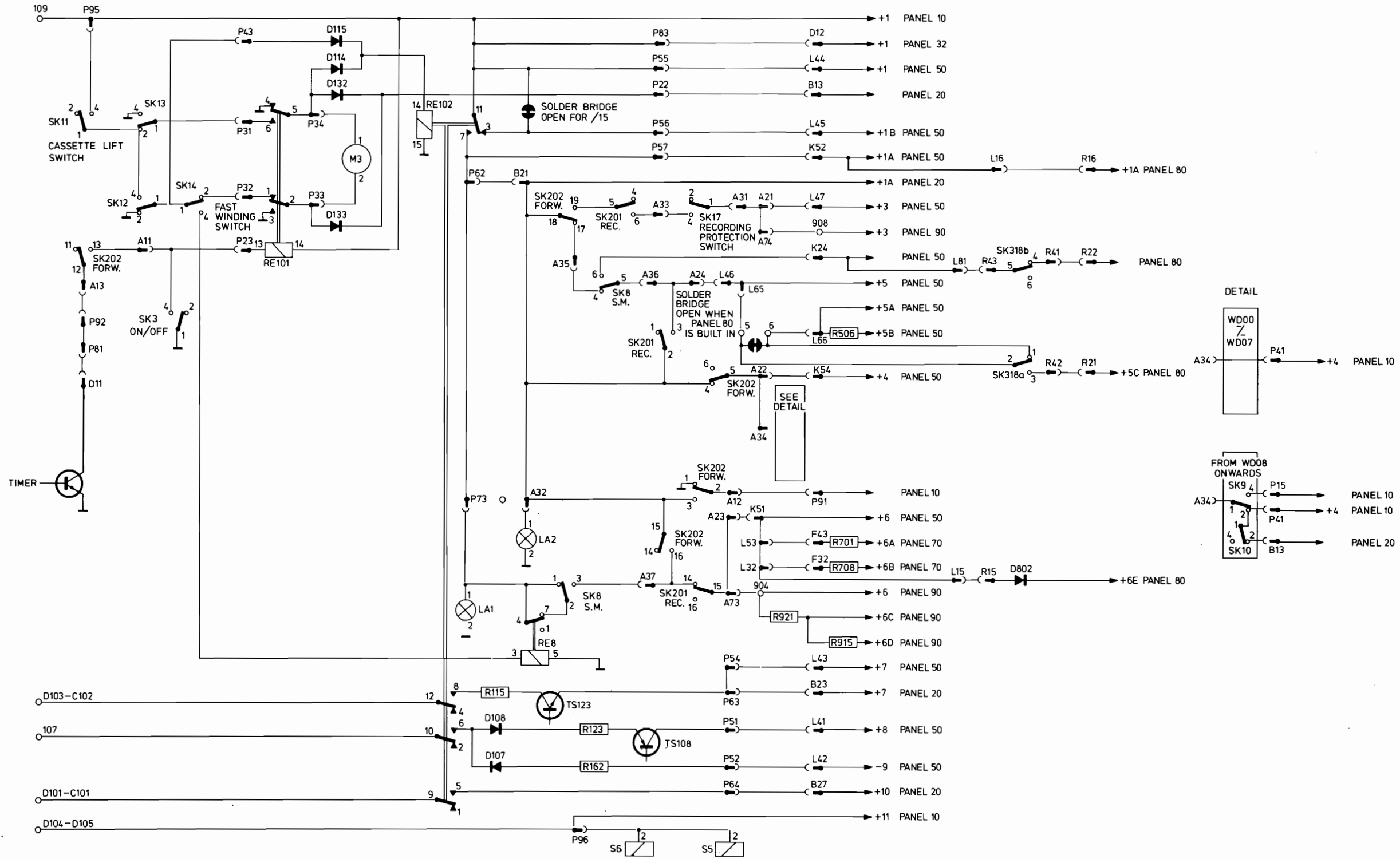

— WIRING  
 ○ MEASURING POINT

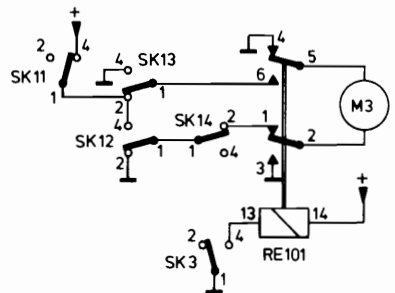

THREADED OUT

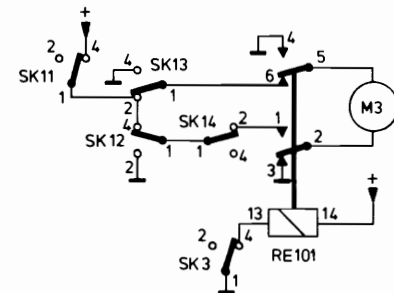

THREADING IN

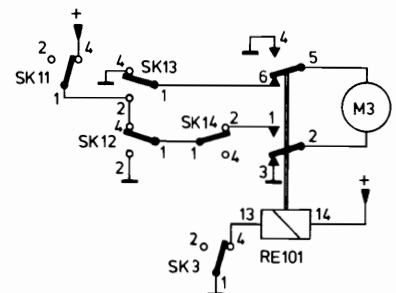

THREADED

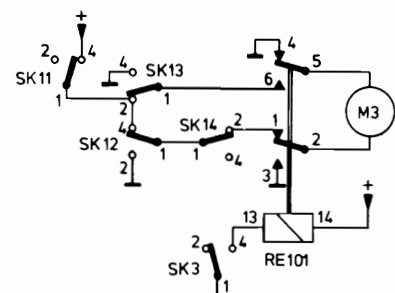

THREADING OUT



MAIN WIRING DIAGRAM A

R	554	555	551	540	556	553	550	545	542	515	549	514	544	519	522	517	518	533	503	507	502	531	506	530	511	510	501	508	509	513	505	704	710	707	705	709	708	713	711	903	904	910	901	909	801	808	802	807	804	806	914	925	918	920	915	916	912	923																																																																																																																																										
C	520	530	531	506	521	525	526	504	509	505	517	507	518	508	502	503	501	523	515	507	502	503	501	523	515	507	502	503	510	507	701	702	706	707	701	710	709	901	902	906	803	807	908	911	924	905	904	906	909	907	910	904	905	906																																																																																																																																														
TS																																																																																																																																																																																																				
MISC	SK311a SK315b SK312a SK316b SK310a SK317b SK314a SK318b SK318																												VL501 BU504 US15 D514 KT502 US09 US13																												KT501 BU3 US10																												S501 TD501 S502 D508 S504 US11 D513 D501 U508 U552 D516 D502 D503 D506 BU2 U553																												S703 S704 S706 U701 U704 S705 S701																												S902 D805 RE802 RE901 D804 BU801 D801 D803 S901VL802																												BU802 BUR01																											

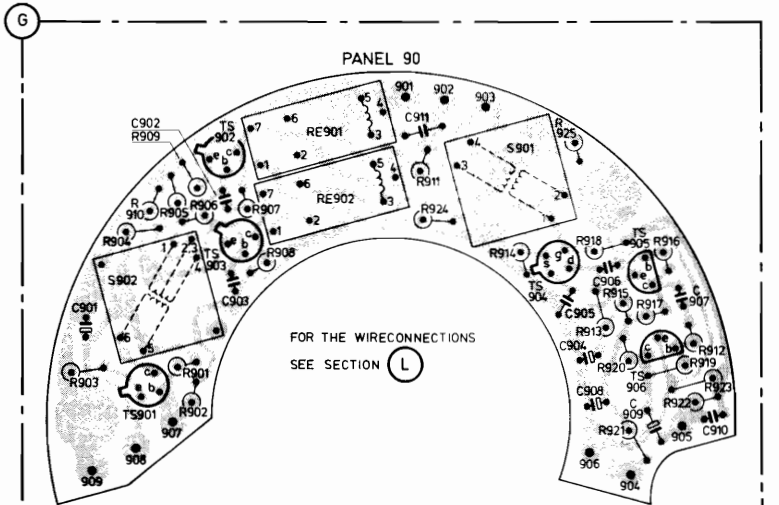
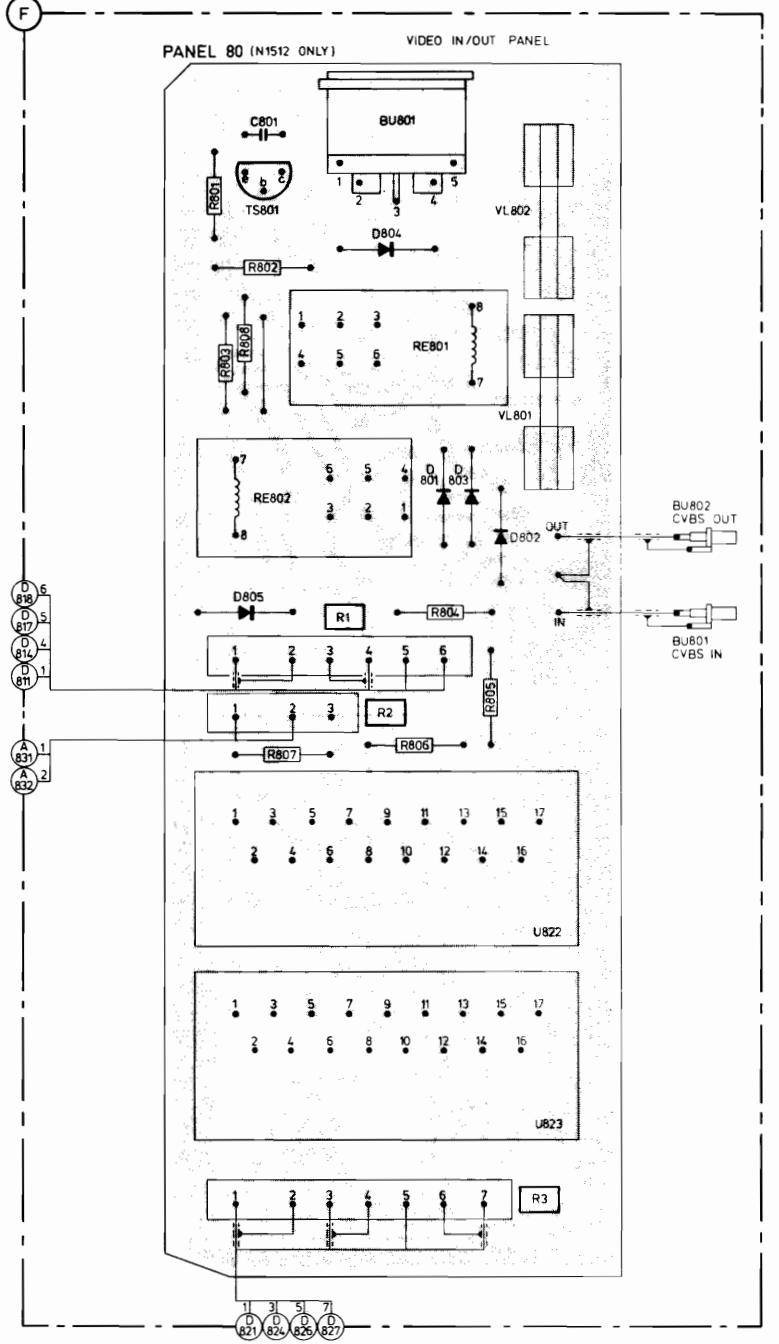
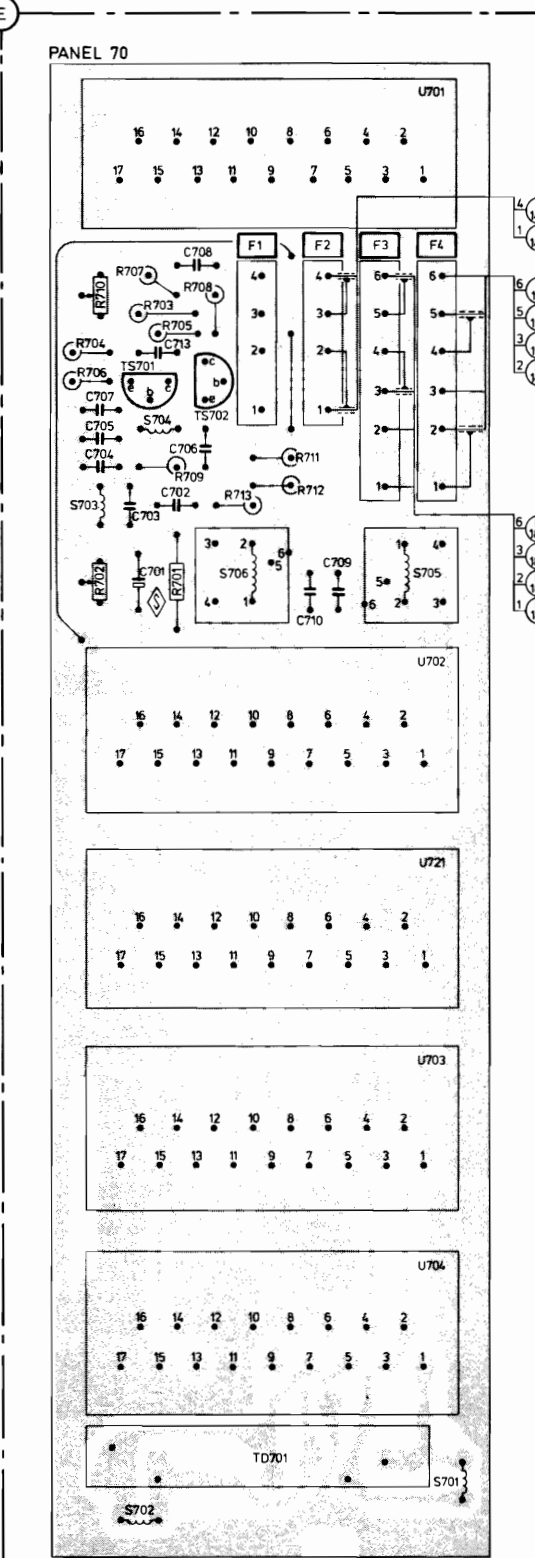
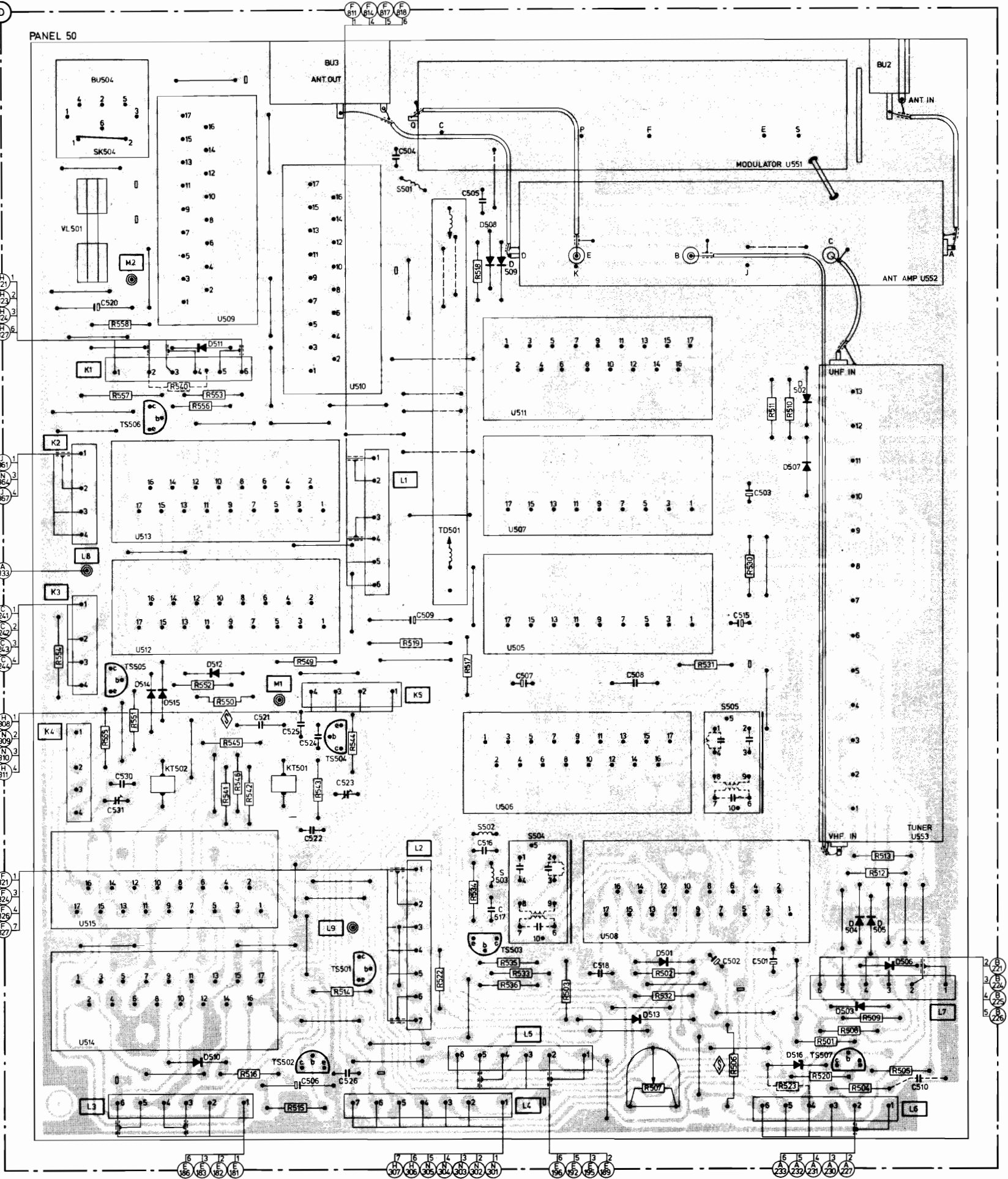
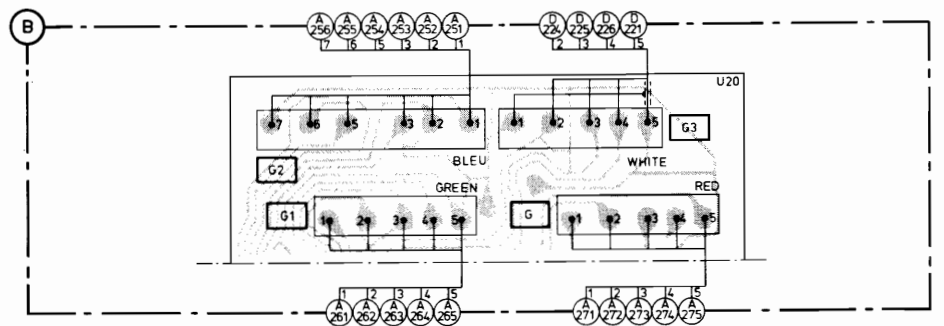
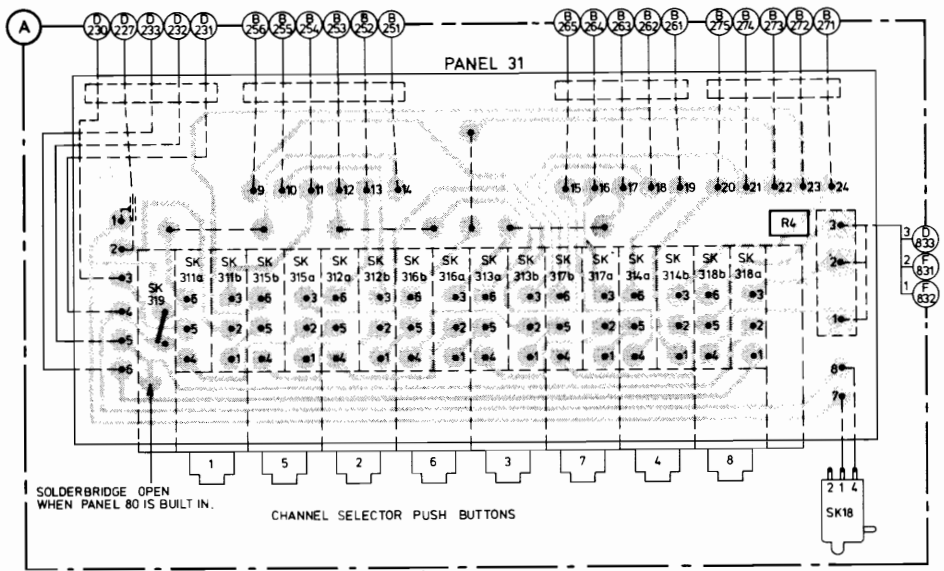



MAIN WIRING DIAGRAM B

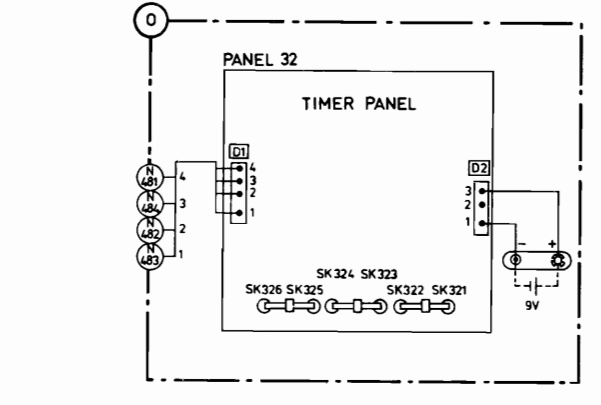
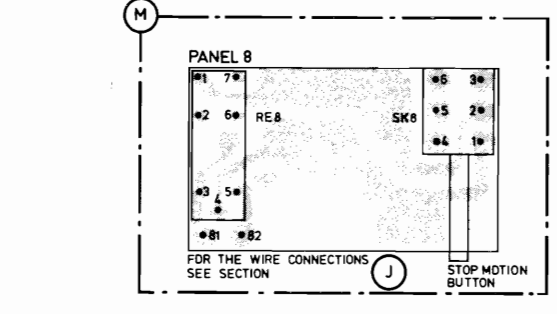
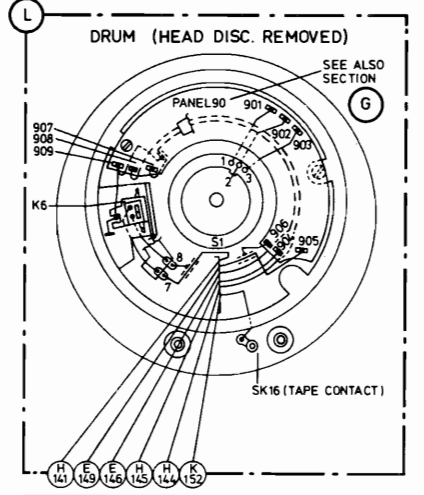
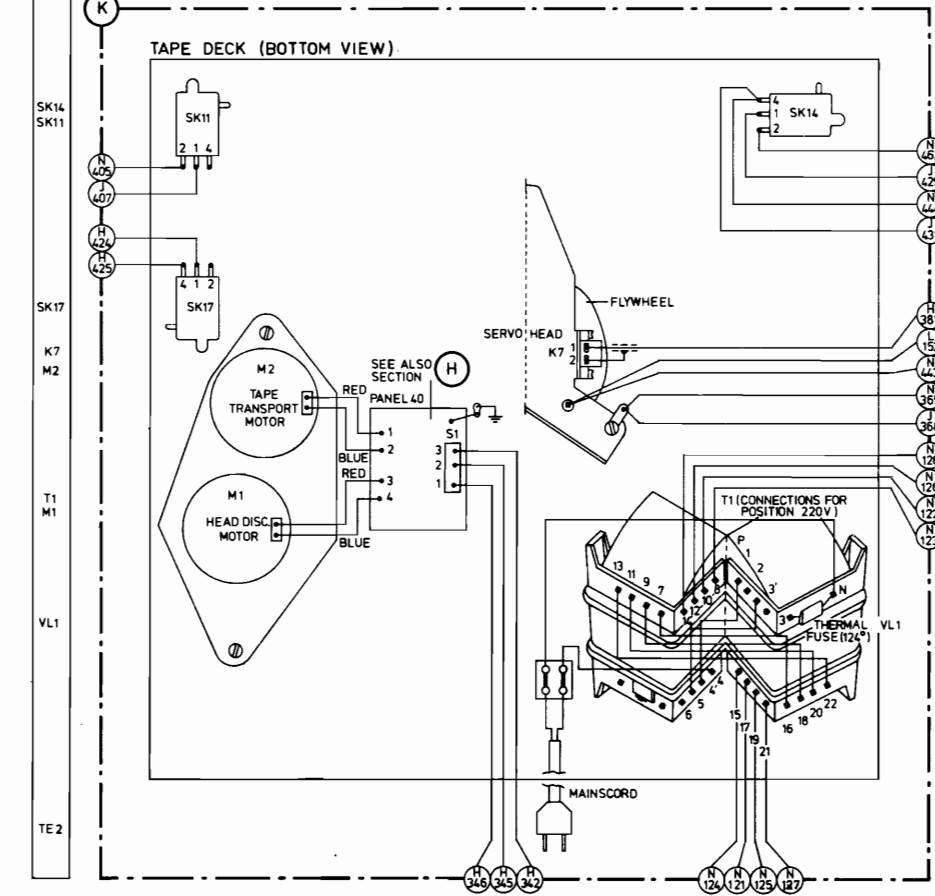
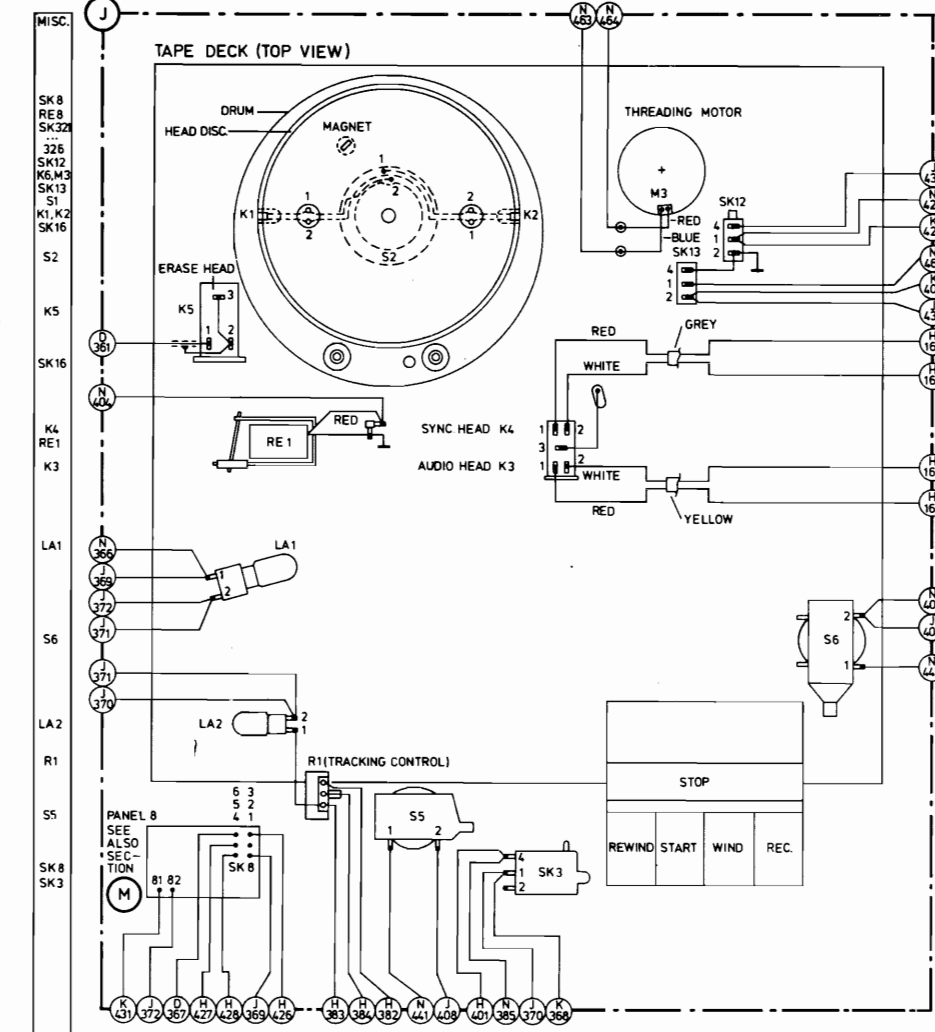
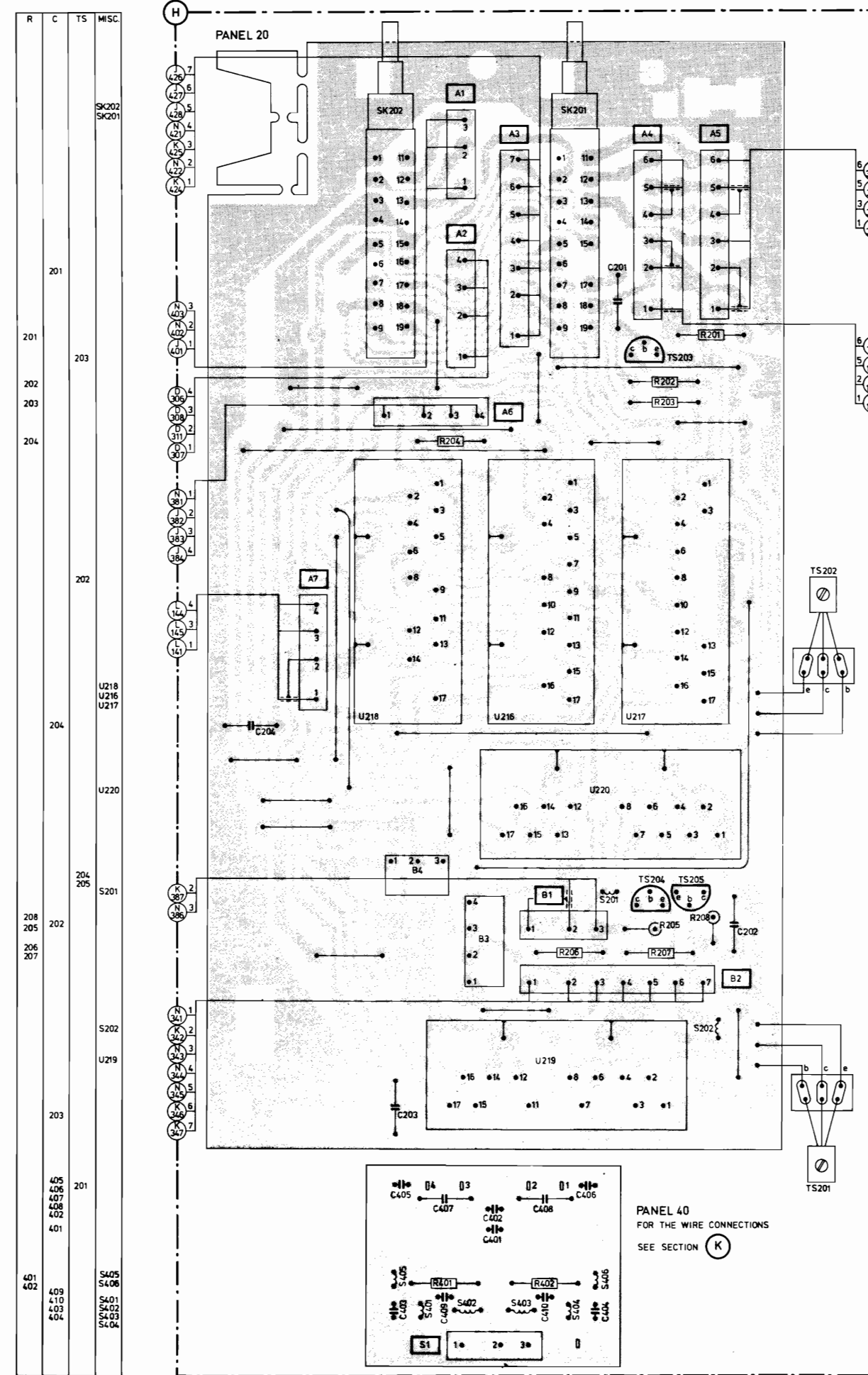

R	143	129	133	144	135	145	153	152	147	161	154	160	134	156	158	127	163	101	103	162	124	123	167	110	117	104	109	169	171	118
C	118	112	114-116	124	113	120	123	127	131	125	130	117	134	108	109	132	104	111	103	106	124	102	107	105	103	1	123	106	101	107
TS	110	109	111	117	112	114	118	126	113	119	115	126	101	108	108	108	108	108	108	108	108	108	108	108	108	108	108	108	108	108
MISC.	D18	D17	D128	D120	D121	D119	D123	D111	D129	D134	RE101	D114	VL102	D110	D112	D107	D109	D101	D106	VL101	D102	RE102	D105	D103	D103	D103	D103	D103	D103	D103

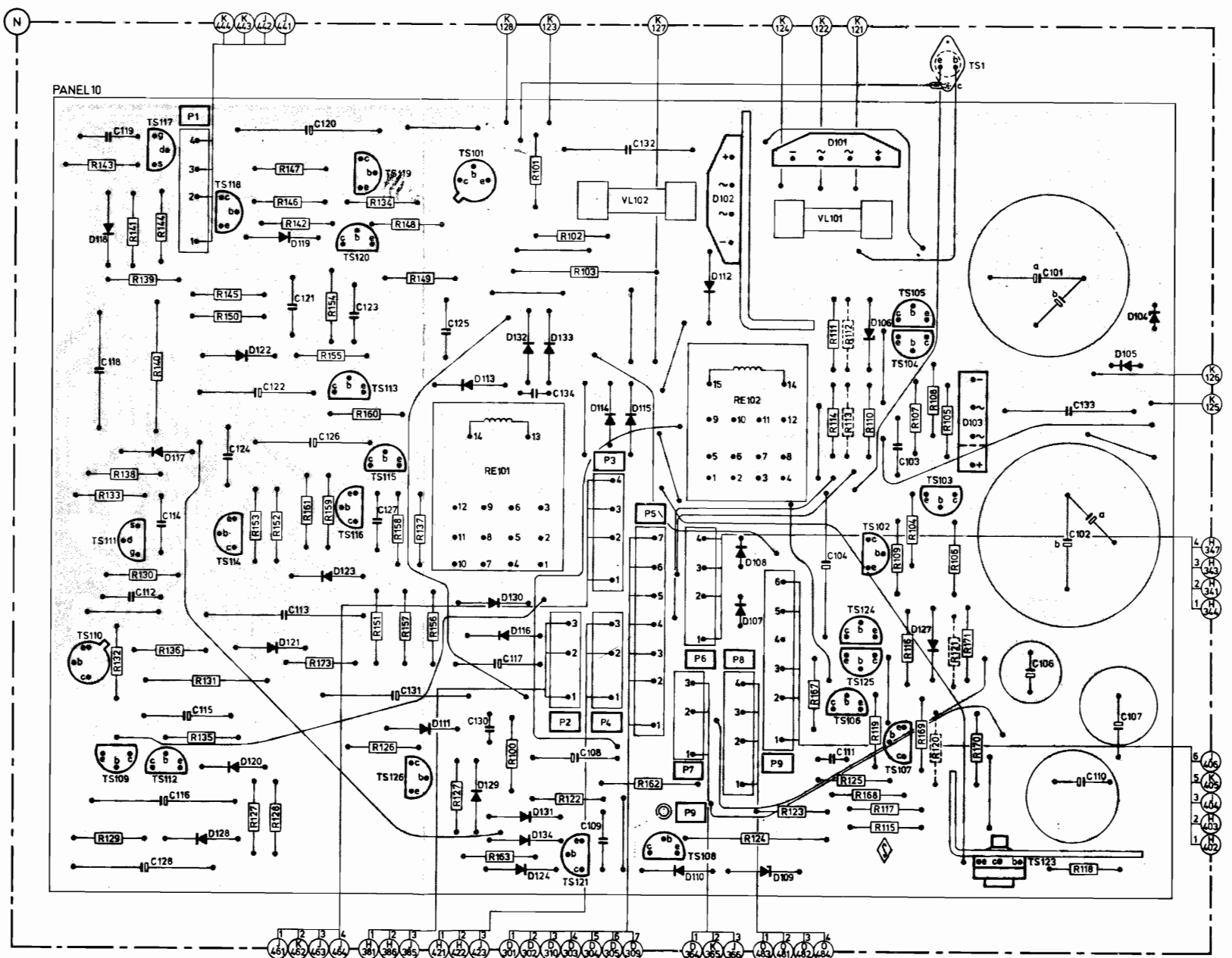











MAIN WIRING DIAGRAM B (ADAPTED TO FACTORYCODE WD10)

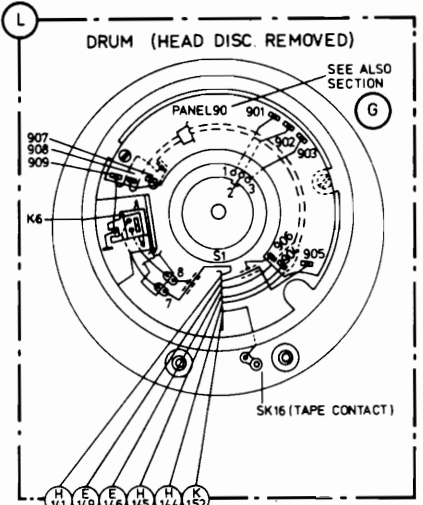
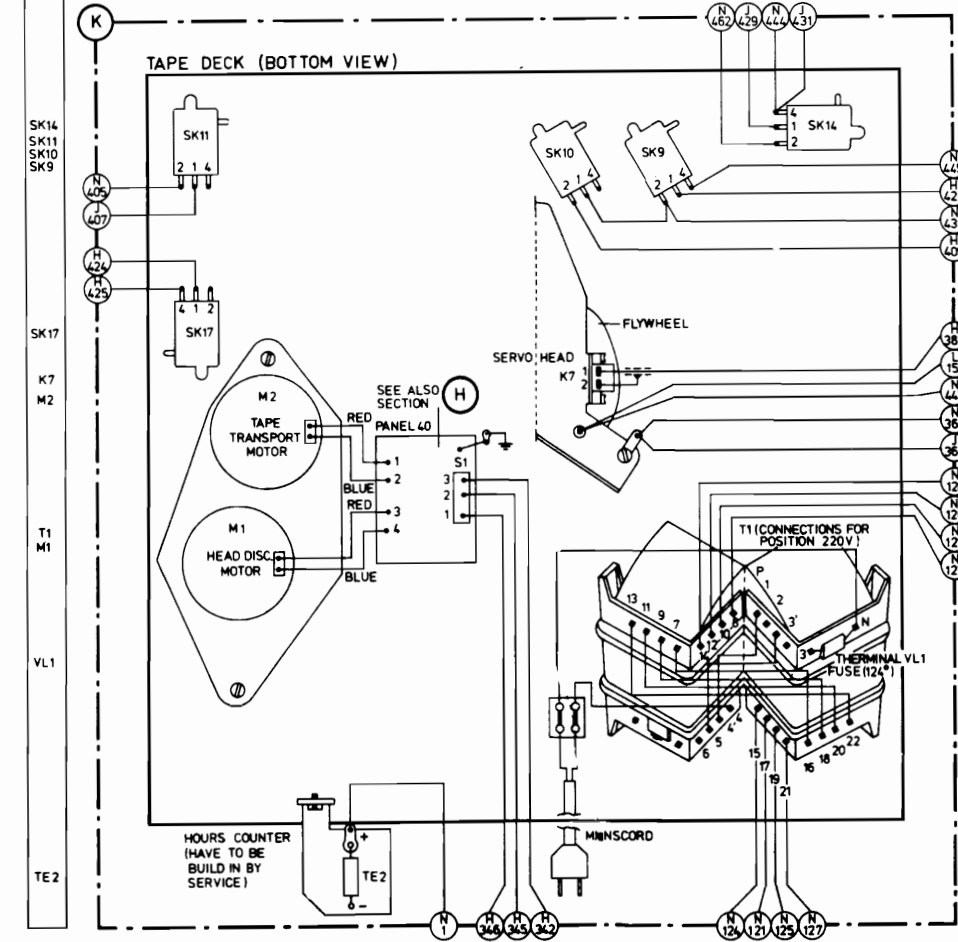
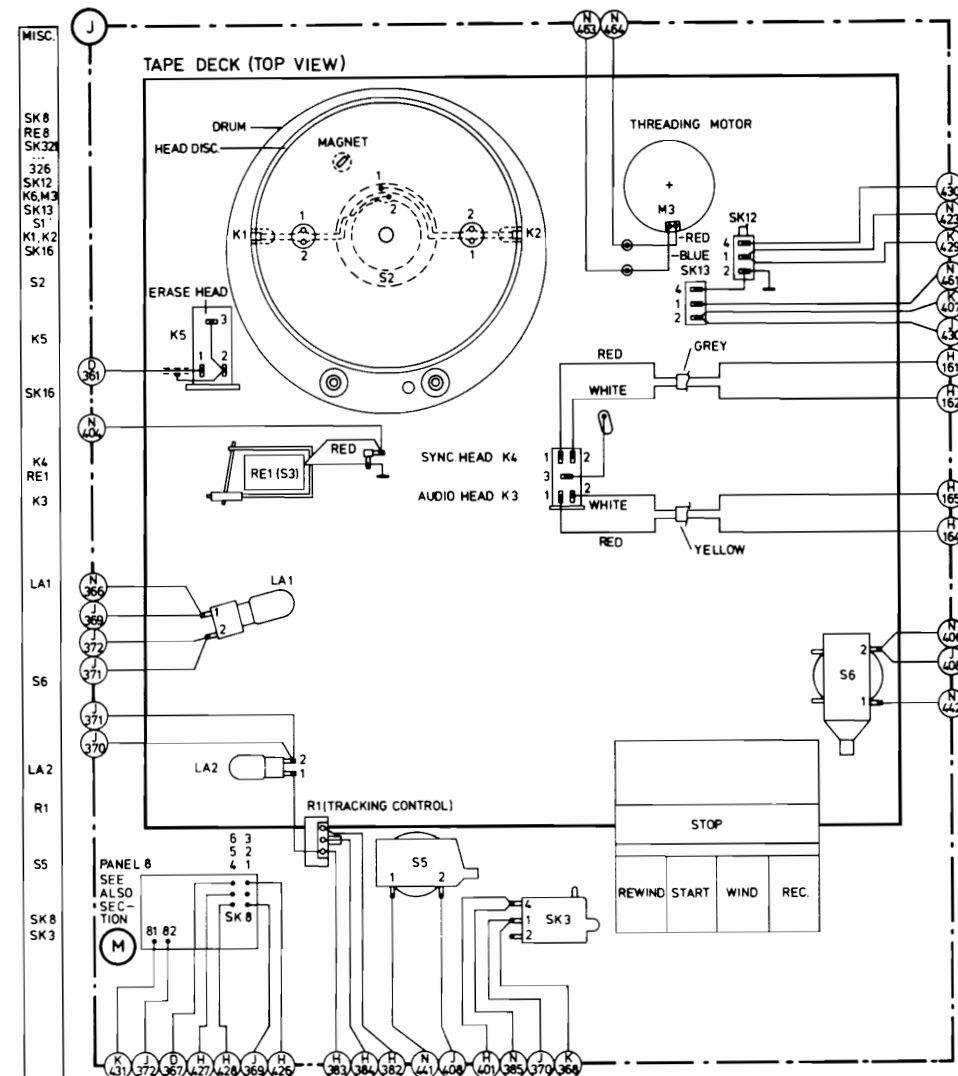
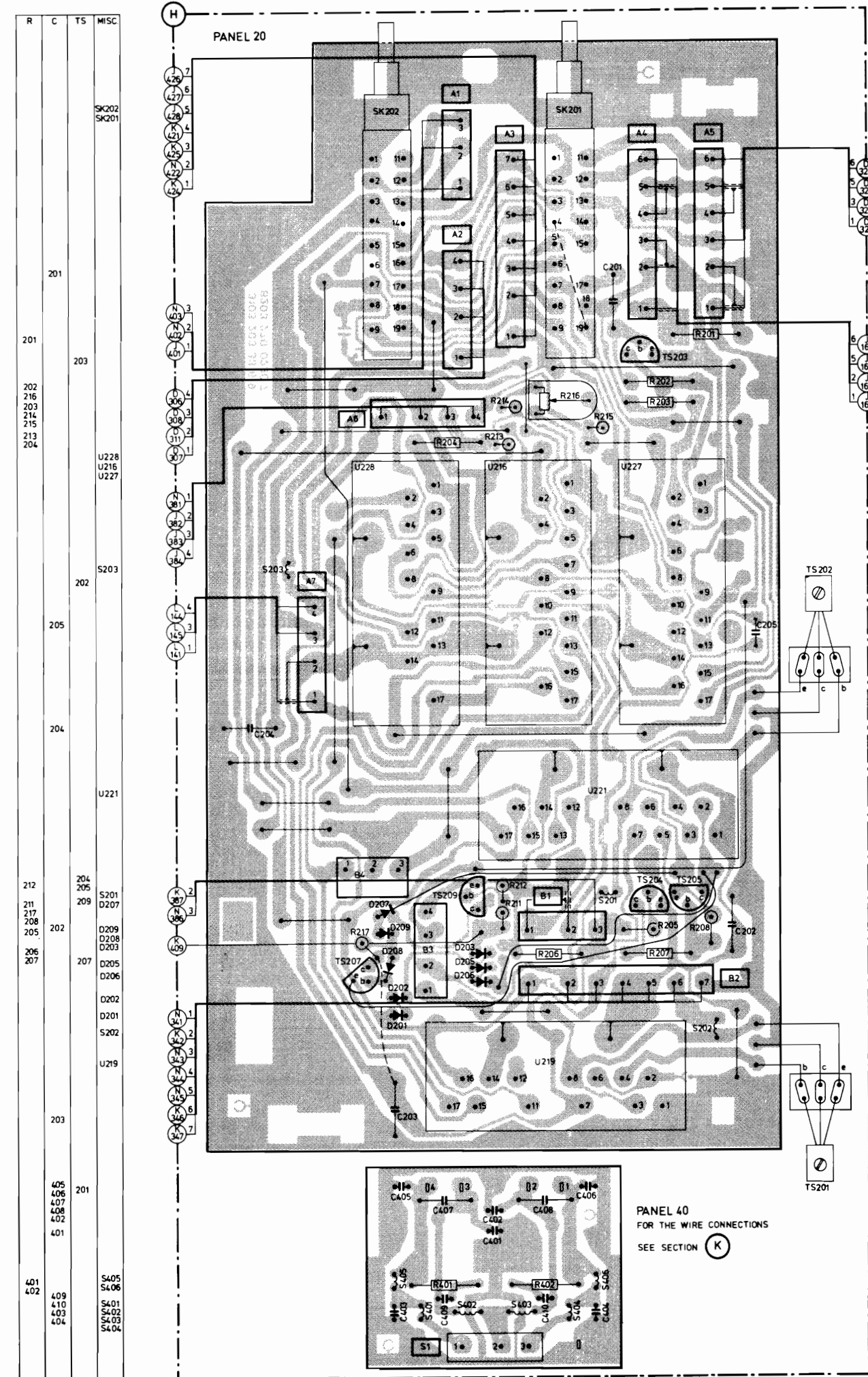

R	43	129	133	144	135	145	153	152	147	161	154	160	134	156	158	163	101	103	162	124	123	167	110	117	104	109	169	171	118	
C	118	112	114-116	124	124	113	120	123	127	131	125	130	117	134	108	109	132	104	111	119	103	106	101	133	110	107	102			
TS	110	109	111	117	112	118	114	116	120	119	115	126	105	121	101	121	108	125	104	106	102	107	105	103	1	123				
MISC.	D18	D117	D128	D120	D121	D119	D122	D123	D134	D132	D111	D129	D131	RE101	D114	VL102	D110	D112	D107	D109	D101	D106	D127	D103	D105	D104				

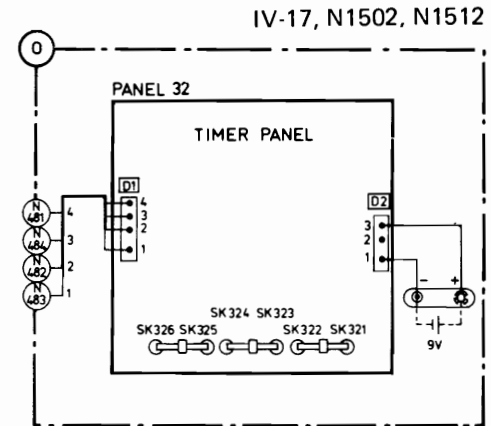
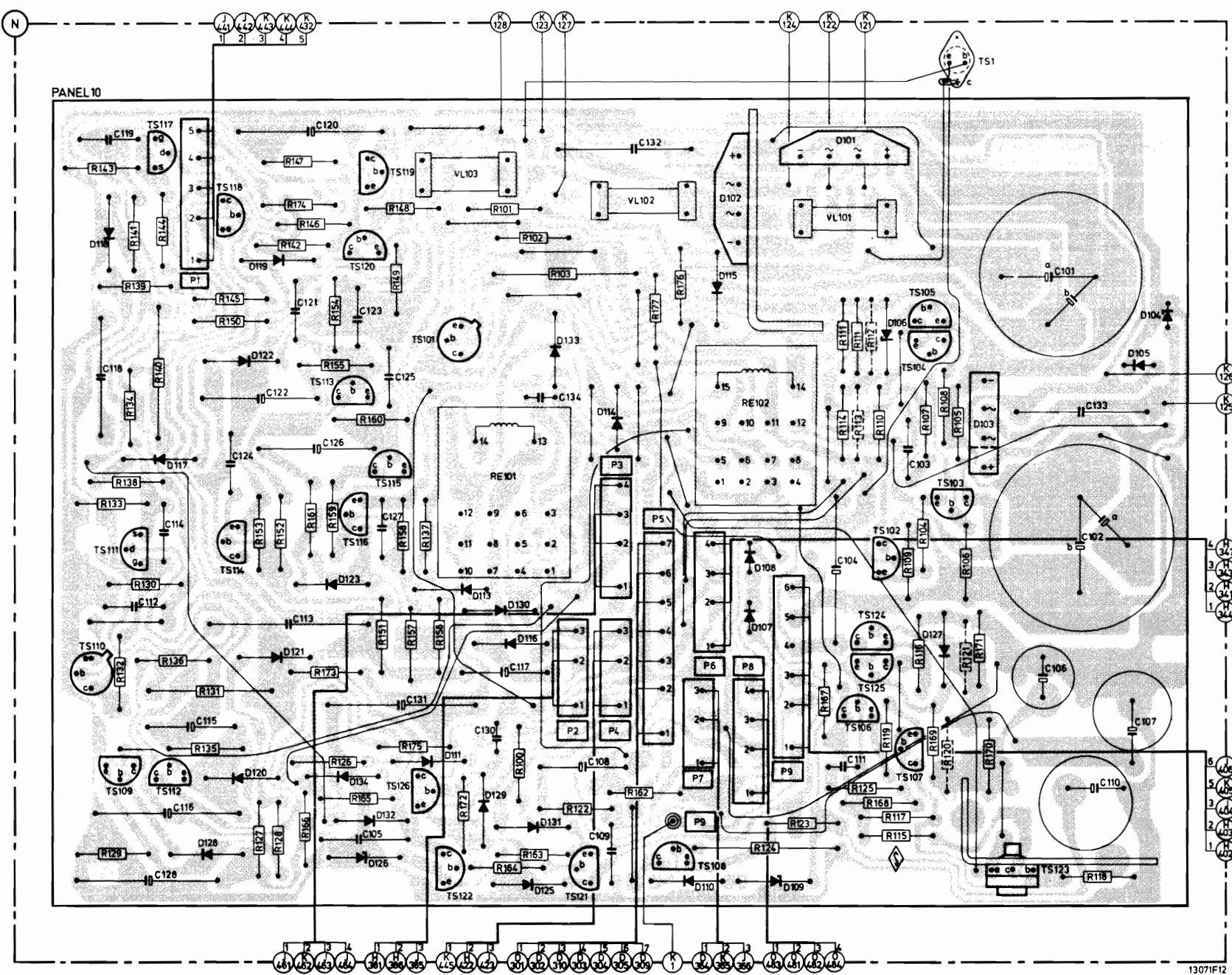

IV-17, N1502, N1512



**V. EXPLODED VIEWS AND SERVICE PARTS**

<b>Contents</b>	<b>Page</b>
1. Exploded view: cabinet	3
tape deck	4
2. List of mechanical parts	5
3. List of auxiliaries	6
4. List of electrical parts	7
5. List of connecting cables	9



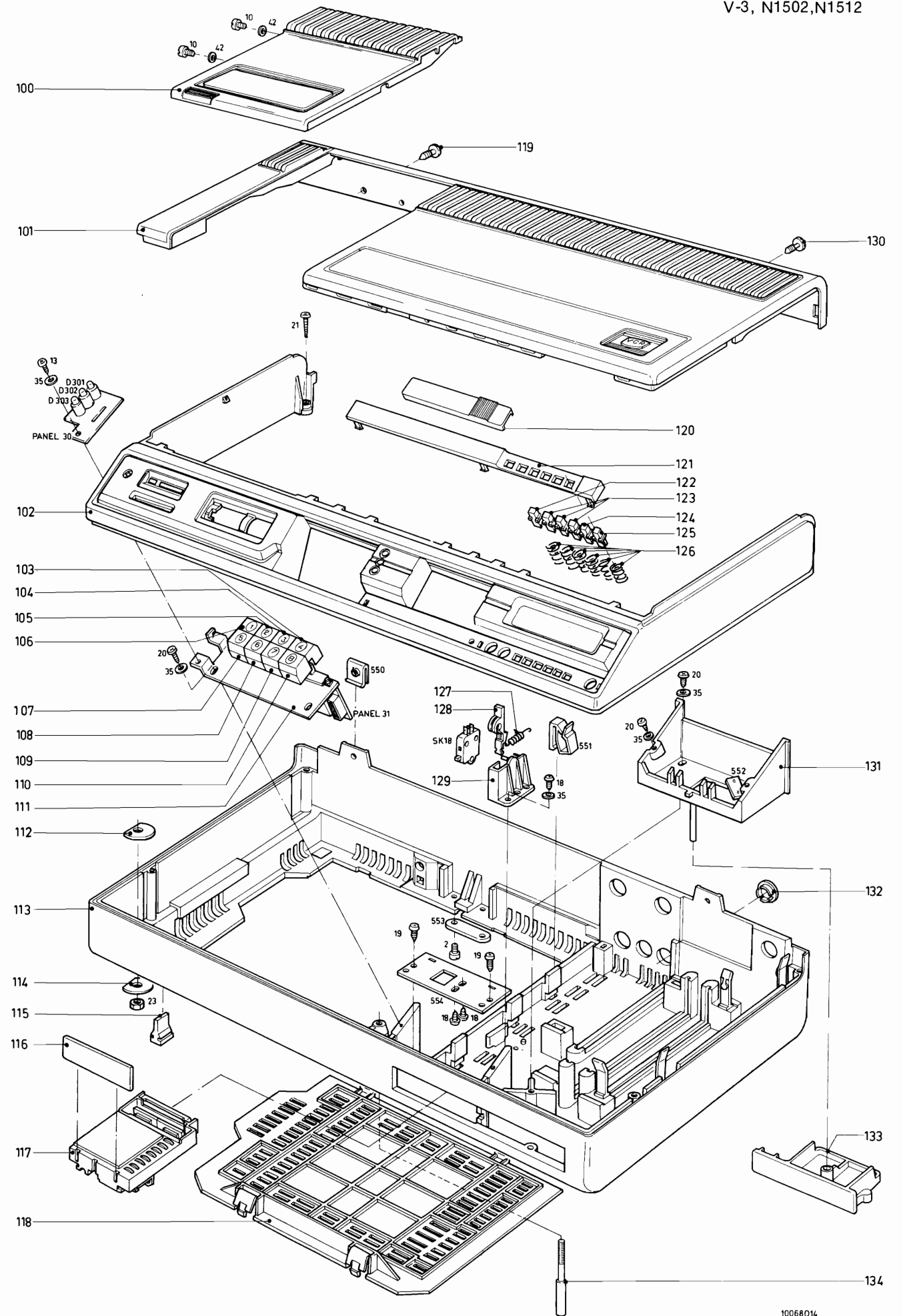

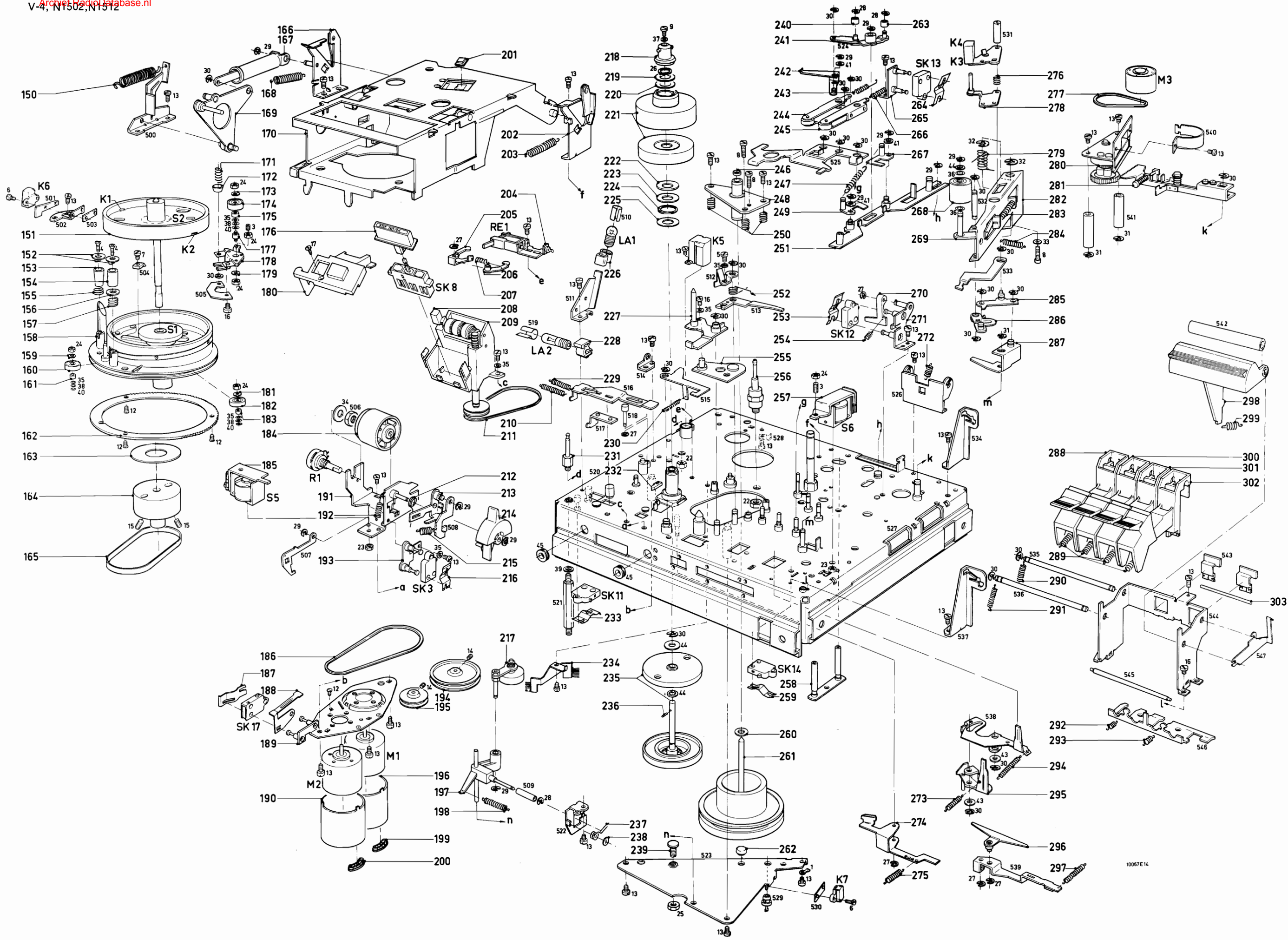

10067E14



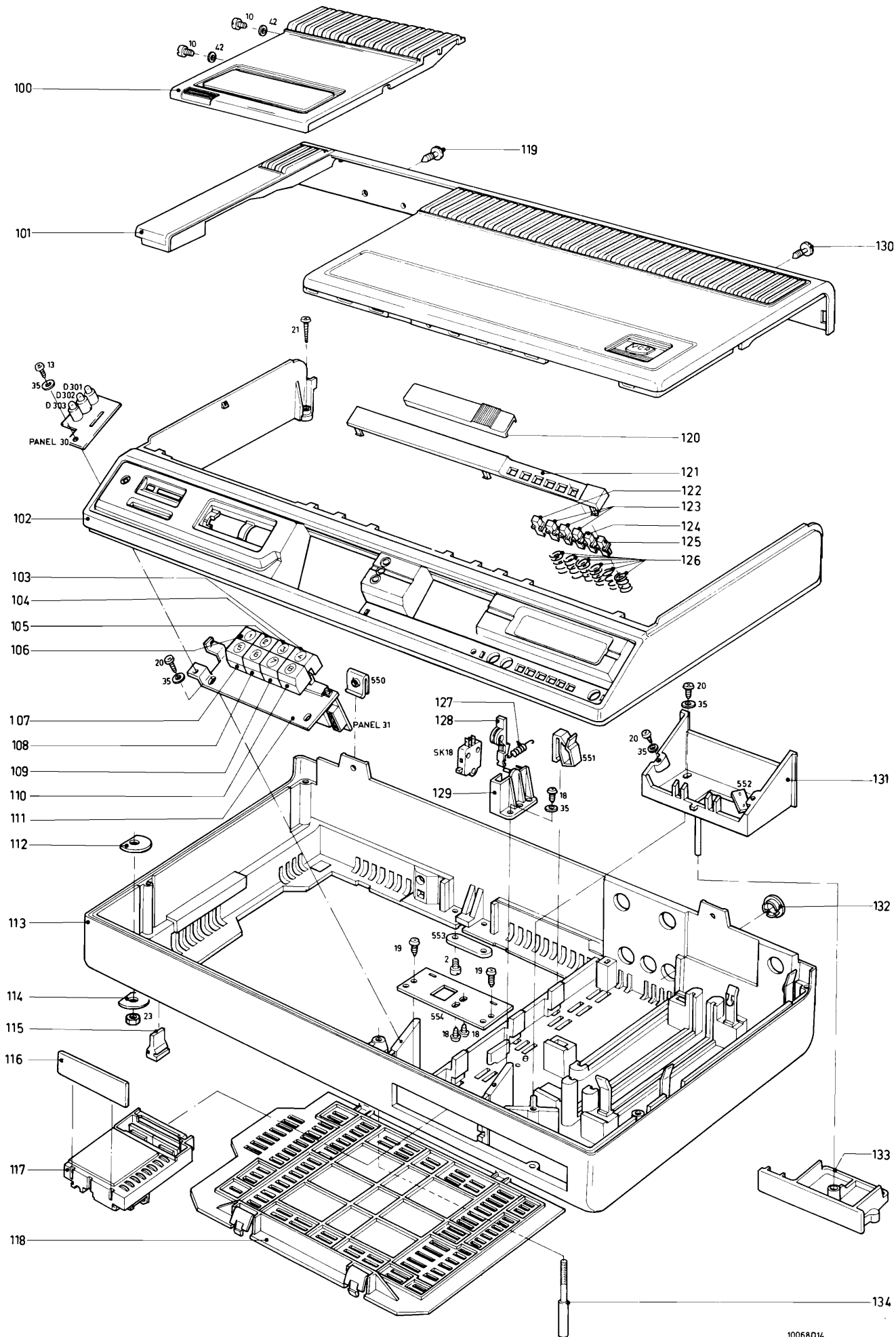

10068014

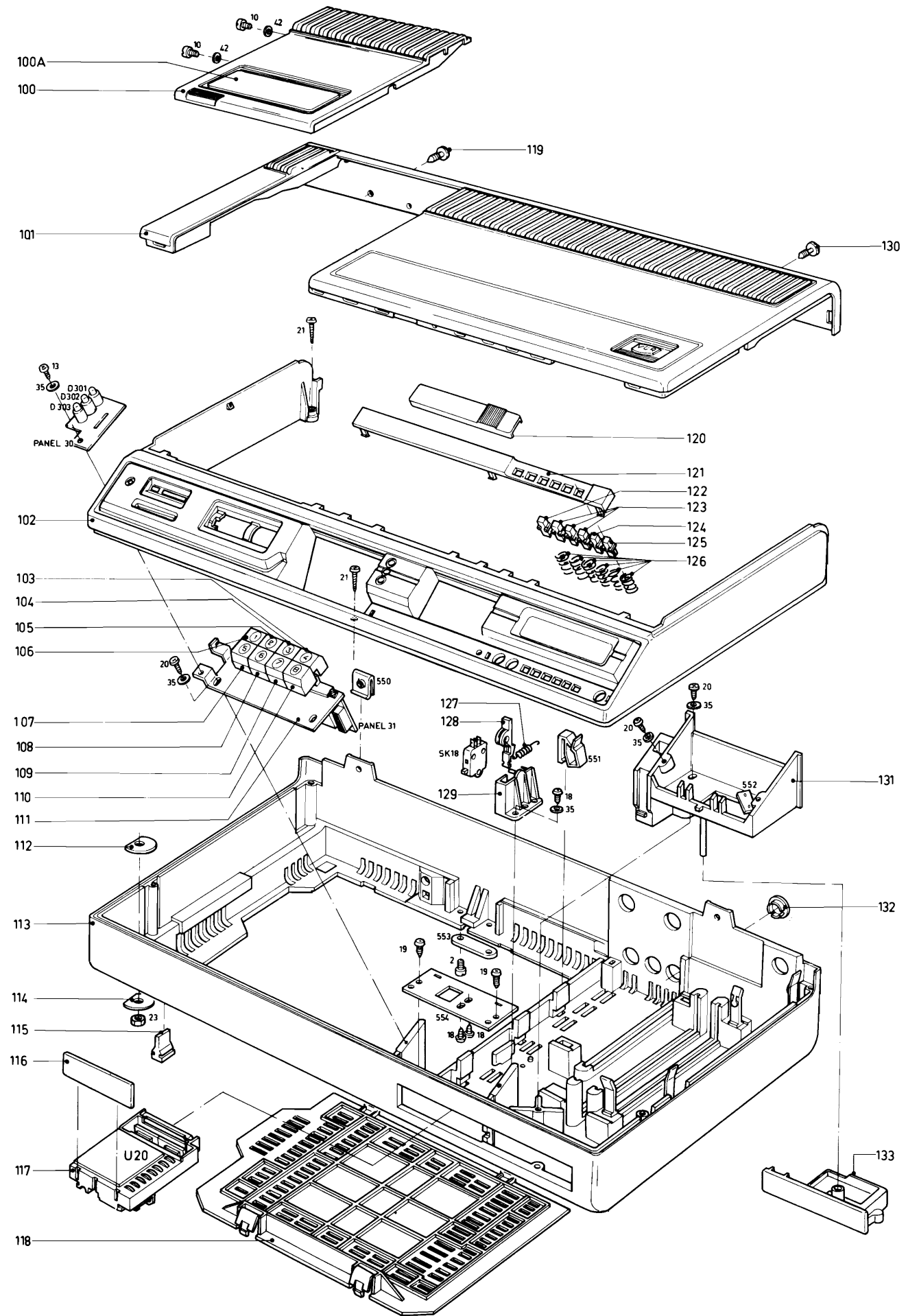

10068014A

(ADAPTED TO FACTORYCODE WD11)

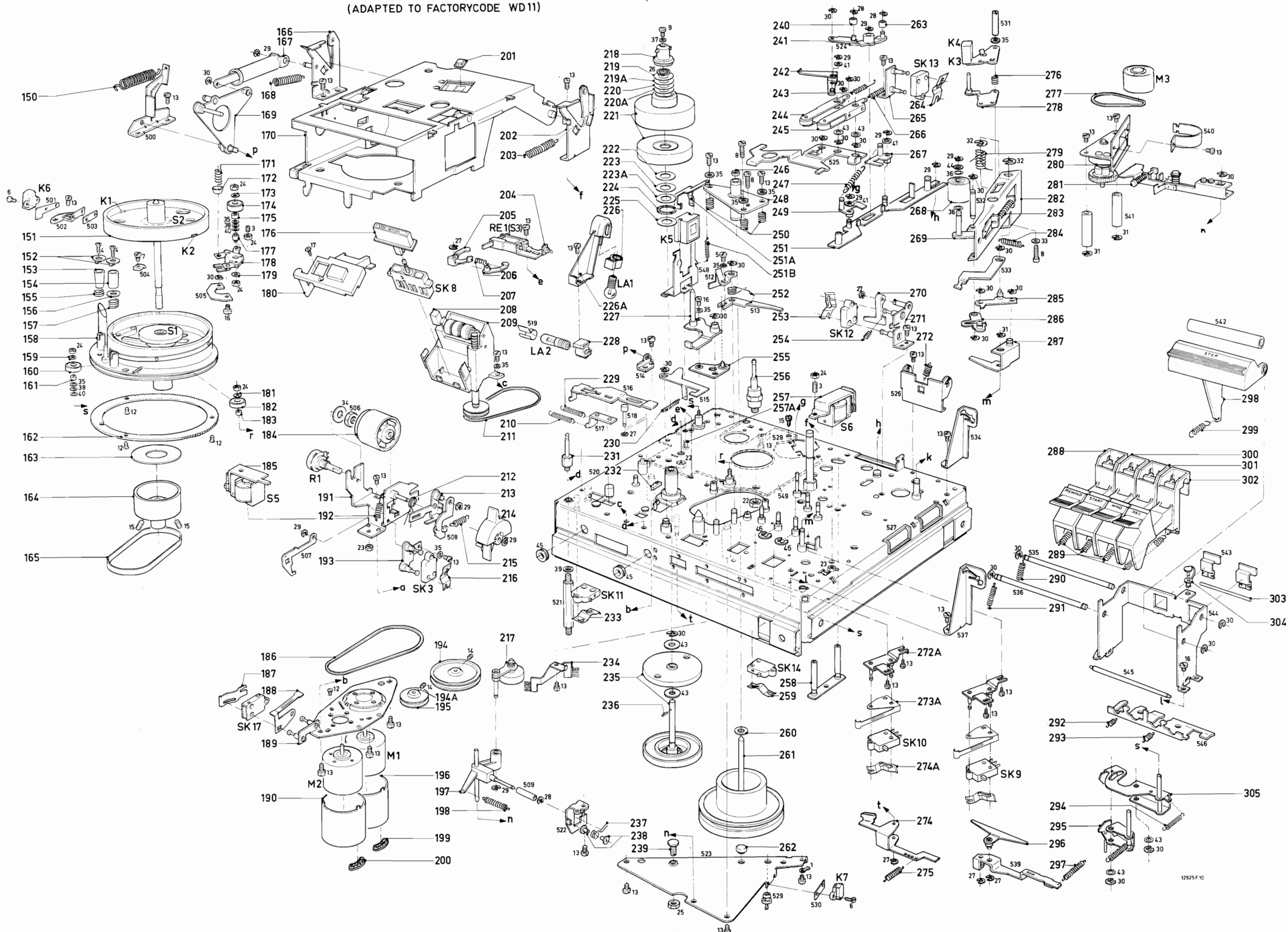

12925 F 10



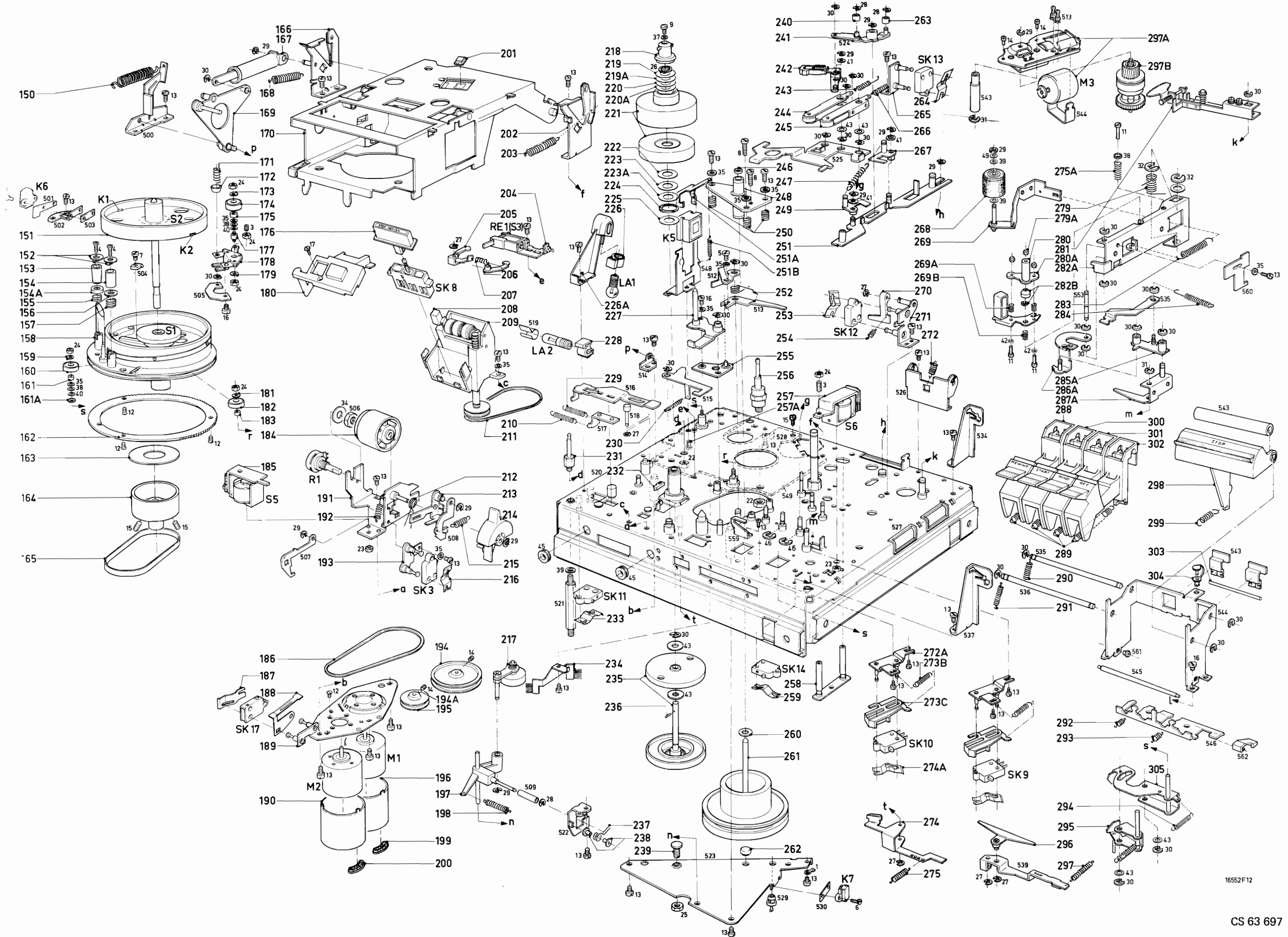

**MECHANICAL PARTS LIST**

**Mounting material**

1	Soldering tag 3x12 mm	5322 290 30079
2	Screw M3x14	5322 500 14001
3	Grub screw M3x10	4822 502 10016
4	Screw M3x16x10	4822 502 10095
5	Screw M3x5	4822 502 10558
6	Screw M2x8	4822 502 10681
7	Screw M3x10	4822 502 10689
8	Screw M3x15	4822 502 10691
9	Screw M2.5x8	4822 502 10909
10	Screw M2.5x5	4822 502 10951
11	Screw M3x12	4822 502 10974
12	Screw M3x5	4822 502 11022
13	Screw M3x6	4822 502 11064
14	Grub screw M3x6	4822 502 11107
15	Grub screw M4x5	4822 502 11109
16	Screw M3x4	4822 502 11189
17	Self-tapper	4822 502 30001
18	Self-tapper	4822 502 30048
19	Self-tapper	4822 502 30085
20	Self-tapper	4822 502 30091
21	Self-tapper	4822 502 30092
22	Nut M8	4822 505 10009
23	Nut M4	4822 505 10262
24	Nut M3	4822 505 10325
25	Nut M5	5322 505 10327
26	Retaining ring 12 mm	4822 530 70029
26	Retaining ring 10 mm from week 714	4822 530 70028
27	Retaining ring 2.3 mm	4822 530 70043
28	Retaining ring 1.9 mm	4822 530 70122
29	Retaining ring 3.2 mm	4822 530 70123
30	Retaining ring 4 mm	4822 530 70124
31	Retaining ring 5 mm	4822 530 70125
32	Retaining ring 6 mm	4822 530 70126
33	Retaining ring 3.2 mm	4822 532 10668
34	Ring 10.5x18x1.5 mm	5322 532 10214
35	Ring 3.2x7x0.5 mm	4822 532 10332
36	Ring 4.2x7x0.1 mm	5322 532 10466
37	Retaining ring 2.6 mm	4822 530 80183
38	Ring 3.2x8x0.1 mm	4822 532 10479
39	Ring 5.3x15x1.5 mm	4822 532 10634
40	Ring 3.2x8x0.3 mm	4822 532 10704
41	Ring 4.3x8x0.5 mm	5322 532 14061
42	Ring 2.7x6.5 mm	5322 532 14464
43	Ring PVC 5.1x9x0.5 mm	4822 532 50301
44	Ring PVC 4.2x7x0.5 mm	4822 532 51005
45	Grommet	4822 325 60031
46	Retaining ring 8 mm	4822 530 70166
47	Self-tapper	4822 502 84012
48	Screw M4x8	4822 502 10693
49	Retaining ring	4822 532 10668

**Cabinet parts**

100	Cassette lift cover	4822 443 10053
100A	Lens	4822 450 60142
101	Cover plate	4822 443 20085
102+120 ...126	Front frame	4822 443 50248
102 etc.	Front frame from WD07/704	4822 443 50264
103	Key 4	4822 410 21764
104	Key 3	4822 410 21763
105	Key 2	4822 410 21762
106	Key 1	4822 410 21761
107	Key 5	4822 410 21765
108	Key 6	4822 410 21766
109	Key 7	4822 410 21767
110	Key 8	4822 410 21768
111	PC-board 31 with switches	4822 214 30398
112	Ring	4822 266 80665

113	Plinth	4822 443 50251
113	Plinth from WD07/704	4822 443 50265
114	Ring	4822 466 80665
115	Foot	4822 462 40306
116	Cover plate	4822 460 20162
117	Drawer	4822 218 20083
118	Bottom plate	4822 443 50247
119	Screw	4822 502 11345
120	Slider	4822 454 20364
121	Strip	4822 454 20363
122	Key	4822 410 21759
123	Key	4822 410 21758
124	Key	4822 410 21769
125	Key	4822 410 21771
126	Pressure spring	4822 492 51141
127	Tension spring	4822 492 31301
128	Bracket	4822 403 50897
129	Bracket	4822 443 60519
130	Screw	4822 502 11345
131	Bracket	4822 403 50896
131	Bracket from WD07/704	4822 404 60116
132	Plug	4822 532 60623
133	Drawer	4822 443 60518
134	Screw till WD07/704	4822 502 11348

**Chassis parts**

150	Tension spring	4822 492 31303
151	Head disc	4822 691 20054
152	Disc	4822 532 20643
153	Tape guide	4822 532 20645
154	Tape guide	4822 532 20646
154A	Disc	4822 532 60094
155	Pressure spring	4822 492 51022
156	Ring	4822 532 10662
157	Pressure spring	4822 492 51022
158	Drum	4822 528 80627
158	Drum from 847	4822 528 80726
159	Ring	4822 532 10698
160	Roller	4822 532 10701
161	Bush	4822 532 10702
161A	Ring 3.2x8x0.2 mm	4822 532 10722
162	Ring	4822 532 10699
163	Ring	4822 532 10697
164	Pulley	4822 528 90255
165	Belt head disc	4822 358 20032
166	Bracket	4822 403 50903
167	Attenuator	4822 360 40091
168	Tension spring	4822 492 31137
169	Lever	4822 403 50919
170+201	Cassette lift	4822 691 20081
171	Pressure spring	4822 492 51147
172	Ring	4822 532 10581
173	Ring	4822 532 10698
174	Roller	4822 532 10701
175	Bush	4822 532 10702
176	"Stop motion" key	4822 410 40115
177	Pin	4822 500 10192
178	Bracket	4822 403 50914
179	Ring	4822 532 10698
180	Lense	4822 381 10439
181	Ring	4822 532 10698
182	Roller	4822 532 10701
183	Bush	4822 532 10702
184	"Tracking" key	4822 413 50897
185	Magnet S5	4822 281 50052
186	Belt flywheel	4822 358 30199
187	Clamping spring	4822 492 62058
188	Spring	4822 492 62059
189	Motor plate	4822 403 50922



190	Screening cap	4822 443 60521	257	Magnet S6	4822 281 50051
191	Bracket	4822 403 50898	257A	Screw	4822 505 10569
192	Tension spring	4822 492 30611	258	Strip	4822 403 50921
193	Bracket	4822 403 50908	259	Clamping spring	4822 492 62058
194	Pulley	4822 528 80628	260	Ring	4822 532 50994
194A	Ball from code WD08/710	4822 520 40037	261	Flywheel	4822 528 60096
195	Pulley	4822 528 80629	262	Pivot bearing	4822 462 70126
196	Screening cap	4822 443 60521	263	Roller	4822 528 90254
197	Lever	4822 403 30262	264	Clamping spring	4822 492 62058
198	Tension spring	4822 492 31369	265	Bracket	4822 403 50936
199	Cap	4822 443 40105	466	Tension spring	4822 492 31134
200	Cap	4822 443 40105	267	Bracket	4833 466 80668
201	Carbon brush	4822 466 90831	268	Pressure roller	4822 528 70198
202	Bracket	4822 403 50904	269	Bracket	4822 403 50905
203	Tension spring	4822 492 31137	269A	Pressure spring	4822 492 51144
204	Relay RE1 (S3)	4822 281 50049	269B	Pressure spring	4822 492 51022
205	Bracket	4822 403 50912	270	Bracket	4822 403 50925
206	Bracket	4822 403 50911	271	Bracket	4822 403 50906
207	Tension spring	5322 492 30573	272	Tension spring	4822 492 51142
208	Key	4822 410 30128	272A	Bracket from WD08/710	4822 403 51001
209	Counter	4822 349 50082	273	Tension spring	4822 492 31322
210	Tension spring	4822 492 30614	273A	Bracket from WD08/710	4822 492 51182
211	Counter belt	4822 358 30123	273B	Pressure spring	4822 492 30611
212	Spring	4822 492 40635	273C	Slider	4822 278 90339
213	Bracket	4822 402 50915	274	Bracket	4822 403 10137
314	Key	4822 411 50411	274A	Bracket from WD08/710	4822 492 62058
215	Tension spring	4822 492 31304	275	Tension spring	4822 492 40539
216	Clamping spring	4822 492 62058	275A	Pressure spring	4822 492 51144
217	Idler wheel	4822 528 90256	276	Pressure spring	4822 492 51144
218	Reel disc	4822 528 10311	277	Belt	4822 358 20101
219	Ring 1 mm	4822 532 50907	278	Bracket	4822 403 50899
220	Ring 0.1 mm	4822 532 10643	279	Spring	4822 492 40636
221	Reel disc	4822 528 10312	279A	Nut	5322 505 14004
222	Ring 0.3 mm	4822 532 50905	280	Threading mechanism	4822 522 31237
223	Ring 0.1 mm	4822 532 10643	280A	Bracket	4822 403 51022
224	Ring	4822 532 10686	281	Bracket	4822 403 50935
225	Ring 0.1 mm	4822 532 10643	282	Bracket	4833 403 50907
from week 714:			282A	Bracket	4822 403 51018
219,219A,			282B	Ring	4822 532 10749
220,220A,			283	Tension spring	4822 492 31302
222,223,			284	Tension spring	4822 492 31318
223A,225	Set with rings	4822 310 30414	285	Bracket	4822 403 50918
221	Reel disc	4822 528 10318	285A	Bracket	4822 403 51021
224	Ring	4822 532 10715	286	Bracket	4822 403 50917
226	Lamp holder	4822 255 10007	286A	Bracket	4822 403 51017
226	Lamp holder from WD08/712	4822 380 20081	287	Bracket	4822 403 50902
226A	Bracket	4822 403 51008	287A	Bracket	4822 403 51019
227	Bracket	4822 503 50909	288	"Rewind" key	4822 410 30123
228	Lamp holder	4822 255 10007	289	Tension spring	4822 492 31324
229	Tension spring	4822 492 30614	290	Tension spring	4822 492 40549
230	Tension spring	4822 492 31165	291	Tension spring	4822 492 30549
231	Cassette roller spindle	4822 535 70508	292	Tension spring	4822 492 31323
232	Brake block	4822 466 40118	293	Tension spring	4822 492 31323
233	Clamping spring	4822 492 62058	294	Tension spring	4822 492 31319
234	Belt brush	4822 479 30061	295	Bracket	4822 403 50901
235	Hysteresis coupling	4822 528 20197	296	Lever	4822 403 50913
236	Pin	4822 535 91055	297	Tension spring	4822 492 31321
237	Spring	4822 492 40634	297A	Plate with worm + motor M3	4822 361 30105
238	Clamp	4822 532 20657	297B	Gear	4822 522 10142
239	Pivot bearing	4822 535 90143	298	"Stop" key	4822 410 30122
240	Roller	4822 528 90254	299	Tension spring	4822 492 31165
241	Bracket	4822 466 80666	300	"Start" key	4822 410 30134
242	Bracket	4822 403 50895	301	"Wind" key	4822 410 30135
243	Tension spring	4822 492 31298	302	"Rec" key	4822 410 30126
244	Bracket	4822 403 40072	303	Spring	4822 492 62057
245	Bracket	4822 403 40073	304	Clamp from week 708	4822 401 10634
246	Ring	4822 532 50995	305	Bracket from week 635	4822 403 50988
247	Tension spring	4822 492 31299		Cooling plate for TS1	4822 511 90008
248	Capstan bearing	4822 520 10376		Insulation plate for TS1	5322 255 40072
249	Bracket	4822 466 80667		Insulation bush for TS1	5322 532 50628
250	Pressure spring	4822 492 51145		Mounting set for TS201,	
251	Strip	4822 403 50916		TS202	4822 255 40115
251A	Spring	4822 492 62106		Cable binder	4822 401 10632
251B	Tension spring	4822 492 31016		Clamping block for mains	
252	Spring	4822 492 40637		flex	4822 290 60204
253	Clamping spring	4822 492 62058		Adapter for BU1	4822 263 50065
254	Tension spring	5322 492 30568			
255	Bracket	4822 466 80669			
256	Cassette roller spindle	4822 535 70507			

**ELECTRICAL PARTS LIST**

**Transistors**

2N2219	5322 130 40496
2N3055	5322 130 40132
BC327	4822 130 40854
BC337	4822 130 40855
BC338	5322 130 44121
BC416C	4822 130 41102
BC547	5322 130 44257
BC547B	4822 130 40959
BC548	4822 130 40938
BC548B	4822 130 40937
BC548C	5322 130 44196
BC549	4822 130 40964
BC557	5322 130 44256
BC558	4822 130 40941
BCY58	5322 130 44129
BD228	4822 130 40929
BD437	4822 130 40982
BF245B	4822 130 41024
BF494	5322 130 44195
BF495	4822 130 40947
BFW11	5322 130 40408
BSX20	5322 130 40417

**Diodes**

BA221	4822 130 30831
BAV20	5322 130 34189
BAW62	5322 130 30613
BY126	5322 130 30192
BY164	5322 130 30414
BY206	4822 130 30839
BY225	4822 130 30917
BY226	4822 130 41119
BZX79/B5V1	5322 130 34233
BZX79/C5V6	5322 130 34173
BZX79/C6V8	5322 130 34278
BZX79/C9V1	4822 130 30862
BZX79/C15	5322 130 34281
BZY88/C3V3	5322 130 30392
OA90	5322 130 30219
FLV150	4822 130 30927
FND357	4822 130 30928

**Integrated circuit**

C2536	IC321	4822 209 80319
-------	-------	----------------

**Crystals**

KT501	4.43 MHz	4822 242 70147
KT502	4.43 MHz	4822 242 70147

**Delay lines**

TD501	540 n.sec.	4822 157 50764
TD701	DL60	4822 157 50864

**Motors**

M1	Head disc motor	4822 361 20137
M2	Tape transport motor	4822 361 20137
M3	Threading motor	4822 361 70304
M3	Plate with worm + threading motor from 802	4822 361 30105

**Fuses**

VL1	12° C	4822 252 20017
VL101	T 3.15 A	4822 253 30027
VL102	T 4 A	4822 253 30038
VL103	T 1 A	4822 253 30021
VL501	0.315 A	4822 253 20012
VL801	T 0.2 A (N1512)	4822 253 30012
VL802	T 0.2 A (N1512)	4822 253 30012

**Relays**

RE1 (S3)	4822 281 50049
RE8	4822 280 60365
RE101	4822 280 80434
RE102	4822 281 50053
RE801 (N1512)	4822 280 70148
RE802 (N1512)	4822 280 70148
RE901	4822 280 60365
RE902	4822 280 60365

**Switches**

SK3	4822 271 30188
SK8	4822 276 20192
SK9	4822 271 30188
SK10	4822 271 30188
SK11	4822 271 30188
SK12	4822 271 30188
SK13	4822 271 30188
SK14	4822 271 30189
SK17	4822 271 30188
SK18	4822 271 30189
SK201	4822 276 30237
SK202	4822 276 30237

**Plugholders + plugs**

BU1 Mainsinlet	4822 265 20169
BU2	4822 267 30084
BU3	4822 265 10021
BU504	4822 267 40238
BU801 (N1512)	4822 267 40284
BU802 (N1512)	5322 267 10004
BU803 (N1512)	5322 267 10004
Measuring block on panel 20	4822 267 50211
3-pole socket	4822 265 30121
4-pole socket	4822 265 30119
6-pole socket	4822 265 30117
7-pole socket	4822 265 40119
Socket for units	4822 267 50189
Socket for unit 507 and 701	4822 267 50196
3-pole plug	4822 266 30071
4-pole plug	4822 266 30072
6-pole plug	4822 266 30073
7-pole plug	4822 266 40057
5-pole plug (black)	4822 267 40225
5-pole plug (green)	4822 267 40224
5-pole plug (red)	4822 267 40223
7-pole plug (blue)	4822 266 40032
Plug for battery	4822 290 80311

**Lamps**

LA1	12 V - 100 mA	5322 134 44014
LA2	18 V - 100 mA	4822 134 40015

**Heads**

K3-K4	Audio-sync head	4822 249 10088
K3-K4	Audio-sync head from 837	4822 249 10107
K5	Erase head	4822 249 40065
K6	Servo head	4822 249 20025
K7	Servo head	4822 249 20025

**Panels**

Panel 32	Clock print	4822 210 20255
Panel 90	Head amplifier	4822 210 20261



**Units**

U216	Saw-tooth generator	4822 210 20217
U217	Tape sync.	4822 210 20218
U218	Lock-in circuit	4822 210 20219
U219	Head servo	4822 210 20221
U220	Tape servo	4822 210 20222
U221	Tape servo	4822 210 20274
U228	Lock-in circuit	4822 210 20279
U505	I.F. amplifier for /00/45	4822 210 20201
U505	I.F. amplifier for /15/43	4822 210 20225
U506	Detector for /00/45	4822 210 20202
U506	Detector for /15/43	4822 210 20223
U507	A.G.C. for /00	4822 210 20203
U507	A.G.C. for /15/43/45	4822 210 20259
U508	Audio automatic tuning for /00/45	4822 210 20204
U508	Audio automatic tuning for /15/43	4822 210 20226
U509	Audio recording	4822 210 20205
U510	Audio playback	4822 210 20206
U511	Signal preparation for /00/45	4822 210 20207
U511	Signal preparation for /15/43	4822 210 20224
U512	562 kHz oscillator	4822 210 20208
U513	Reference	4822 210 20209
U514	Chroma A.G.C.	4822 210 20211
U515	Chroma oscillator	4822 210 20212
U551	Modulator for /00/45	4822 216 90417
U551	Modulator for /15 and /43	4822 216 90422
U552	Wide-band amplifier	4822 216 90416
U552	Wide-band amplifier for /45	4822 216 90437
U553	Tuner for /00 and /15	4822 210 40136
U553	Tuner for /43	4822 210 40148
U553	Tuner for /45	4822 210 40155
U701	FM modulator	4822 210 20213
U702	FM processing	4822 210 20214
U703	FM demodulator	4822 210 20215
U704	Drop-out demodulator	4822 210 20216
U721	Crispning	4822 210 20227
U828	Amplifier (N1512)	4822 210 20241
U823	Splitter (N1512)	4822 210 20242

**Coils**

T1	Mains transformer	4822 146 80081
S3 (RE1)	Relay	4822 281 50049
S5		4822 157 50711
S6		4822 157 50871
S201		4822 158 10224
S202		4822 158 10224
S203		4822 158 10224
S401		4822 158 10224
S402		4822 158 10224
S403		4822 158 10224
S404		4822 158 10224
S405		4822 158 10224
S406		4822 158 10224
S501		4822 157 30192
S502		4822 157 50624
S503		4822 156 10431
S504	for /00/45	4822 156 30547
S504	for /15/43	4822 156 30548
S505	for /00/45	4822 156 60076
S505	for /15/43	4822 156 30436
S701		4822 156 10431
S702		4822 156 10431
S703		4822 156 10429
S704		4822 156 10428
S705		4822 156 20619
S706		4822 156 20619
S901		4822 157 50745
S902		4822 156 60081

**Resistors**

R1	22	kΩ	4822 101 20301
R103	180	Ω	4822 112 21087
R110	910	Ω	5322 116 54545
R111	2.2	kΩ	5322 116 54574
R114	2.87	kΩ	5322 116 50414
R115	10	Ω	4822 111 30405
R123	560	Ω	5322 116 54009
R131	47	MΩ	4822 116 60047
R140	47	MΩ	4822 111 30417
R162	10	kΩ	4822 111 30434
R169	2.87	kΩ	5322 116 54331
R170	9.31	kΩ	5322 116 54616
R171	2.21	kΩ	5322 116 54574
R175	1	Ω	4822 111 30215
R176	1	Ω	4822 111 30215
R177	1	Ω	4822 111 30215
R216	10	kΩ	4822 100 10035
R350	100	kΩ	4822 100 10052
R401	100	Ω	4822 111 30343
R402	100	Ω	4822 111 30343
R506	10	Ω	4822 111 30405
R519	1.2	MΩ	4822 110 42189
R523	5.6	MΩ	4822 110 42207
R550	10	Ω	4822 111 30405
R701	1	Ω	4822 111 30215
R702	1	kΩ	4822 100 10021
R710	4.7	kΩ	4822 100 10025
R903	82	Ω	5322 116 54462
R906	390	Ω	5322 116 54006
R909	22	Ω	5322 116 50983
R910	22	Ω	5322 116 50983
R911	68	Ω	4822 110 53076

**Capacitors**

C101	2x2350	μF - 40 V	4822 124 70226
C102	2x1100	μF - 63 V	5322 124 74068
C104	220	μF - 16 V	4822 124 20473
C106	220	μF - 40 V	4822 124 20532
C107	220	μF - 63 V	4822 124 20537
C108	10	μF - 25 V	4822 124 20475
C110	330	μF - 63 V	4822 124 20538
C115	22	μF - 10 V	4822 124 20459
C116	150	μF - 16 V	4822 124 20586
C117	1.5	μF - 63 V	4822 124 20605
C120	150	μF - 6.3 V	4822 124 20454
C122	33	μF - 40 V	4822 124 20485
C126	33	μF - 40 V	4822 124 20485
C128	100	μF - 10 V	4822 124 20462
C131	100	μF - 10 V	4822 124 20462
C321	22	μF - 25 V	4822 124 20476
C322	22	μF - 25 V	4822 124 20476
C328	47	μF - 10 V	4822 124 20461
C407	100	nF - 100 V	4822 121 41161
C408	100	nF - 100 V	4822 121 41161
C501	22	μF - 63 V	4822 124 20584
C502	33	μF - 16 V	4822 124 20468
C503	100	μF - 25 V	4822 124 20587
C506	15	μF - 16 V	4822 124 20467
C507	47	μF - 40 V	4822 124 20487
C509	10	μF - 25 V	4822 124 20475
C515	10	μF - 63 V	4822 124 20496
C520	10	μF - 25 V	4822 124 20475
C523	22	pF	4822 125 50045
C531	22	pF	4822 125 50045
C701	68	μF - 16 V	5322 124 20377
C702	10	μF - 25 V	4822 124 20475
C709	820	pF	5322 121 54038
C710	820	pF	5322 121 54038
C901	15	μF - 16 V	4822 124 20467
C904	15	μF - 16 V	4822 124 20467
C908	15	μF - 16 V	4822 124 20467
C909	15	μF - 16 V	4822 124 20467

**Auxiliaries**

Service test cassette with recesses	4822 397 60041
Service test cassette with pre-modulated tape	4822 397 60042
Drum level tube	4822 395 80131
Level tube	4822 395 50128
Level tube for pressure roller	4822 395 80083
Bending pipe for adjustment of cassette roller spindles	4822 395 80151
Bending pipe for adjusting the reel disc bearing 10 mm and 12 mm	4822 395 90097

Gauge for adjusting the height of the reel discs	4822 395 80077
Sqaure	4822 395 80078
Gauge	4822 395 80076
Spring pressure gauge 0-35 g.	4822 395 80029
Spring pressure gauge 10-100 g.	5322 395 84011
Spring pressure gauge 300-3000 g.	5322 395 84009
Allen key 2 mm	4822 395 50084
Serviscoop (lamp with mirror)	4822 395 30062
Cleaning set	4822 389 20014

**Cables**

Mains flex for /00	4822 321 10084
Mains flex for /00 from 837	4822 321 10183
Mains flex for /15	4822 323 30002
Mains flex for /15 from 837	4822 321 10184
Mains flex for /43	4822 321 10058
Mains flex for /43 from 837	4822 321 10185

**1. HF Coaxial cable** 4822 321 20352

Pos. 1	Coaxial plug	4822 264 30104
Pos. 2	Coaxial lead (per meter)	4822 322 10026
Pos. 3	Coaxial plug	4822 266 10034

**2. A/V cable** 4822 321 20353

Pos. 1	Plug 6 pole - 240°	4822 264 40099
Pos. 2	Lead	4822 322 40035
Pos. 3	Plug 6 pole - 240°	4822 264 40099

**3. Video cable (bl/wh)**

Pos. 1	Plug 5 pole - 240°	4822 264 40024
Pos. 2	Coaxial lead (per metre)	4822 322 10026
Pos. 3	Coaxial plug	5322 266 10022

**4. Audio cable (mono)** 4822 321 20208

Pos. 1	Plug 5 pole - 180°	4822 264 40023
Pos. 2	2-core lead	4822 322 40024
Pos. 3	Plug 3 pole - 180°	4822 264 40101

**5. Audio cable (stereo)** 4822 321 20207

Pos. 1	Plug 5 pole - 180°	4822 264 40023
Pos. 2	4-core lead	4822 322 10025
Pos. 3	Plug 5 pole - 180°	4822 264 40023

**6. PM9538\*\***

Pos. 1	Coaxial plug	4822 264 30104
Pos. 2	Coaxial lead (per metre)	4822 322 10026
Pos. 3	Coaxial plug	5322 266 10022

\*\*Supplied by Test and Measuring Instruments Dept.

Note: Comm. dept, ELA does not supply cables anymore.

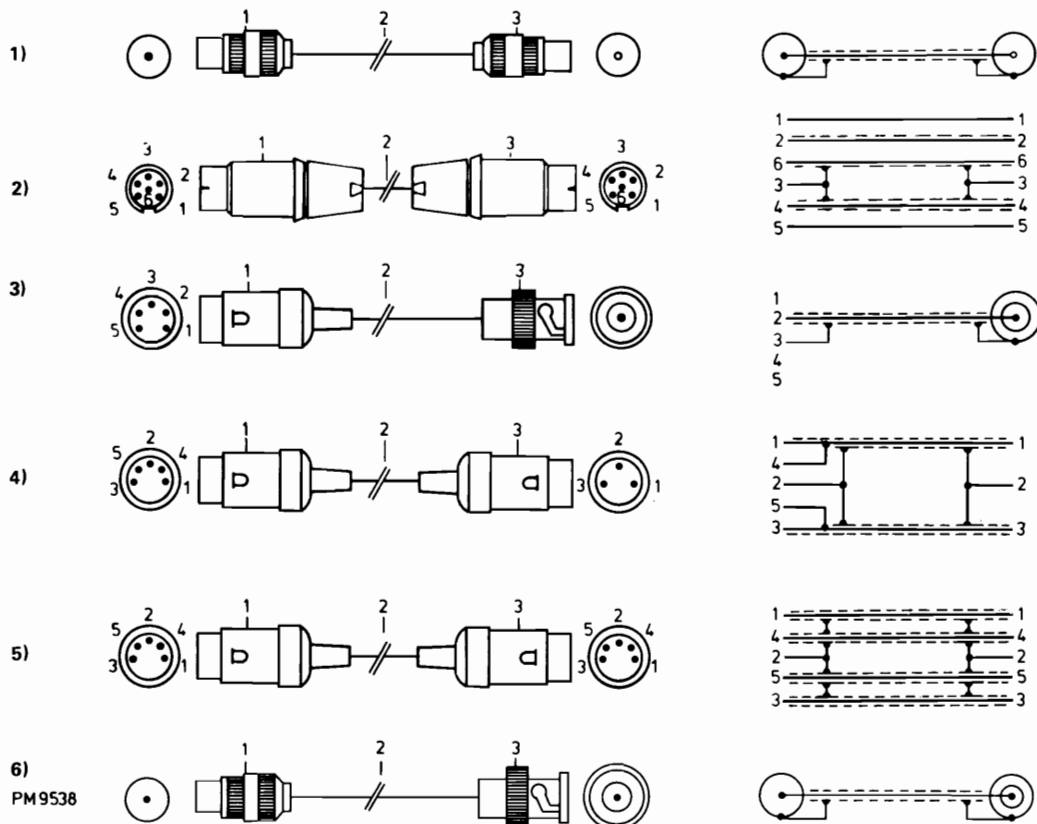



**VI. REPAIR METHOD**

**Contents**

	Page	Date
Repair method		76-09-01
Introduction	VI-2	
Checking procedure	VI-3...VI-5	
Repair procedure	VI-6...VI-12	

## INTRODUCTION

With this repair method the faults occurring most, can be quickly located. The method is split up in two parts, viz. a checking and a repair procedure.

First, the VCR is connected as indicated in the heading of the checking procedure. We take it that the CTV-receiver is well-adapted for playback of VCR-signals.

The VCR must be checked in the sequence indicated by the numbers I...VII of the checking procedure. If no fault is found for a number, then the next point can be checked immediately. Listed under each number are the symptoms of the fault followed by the number of the repair procedure to which is referred. In some cases, there is direct reference to the faulty circuit. The fault that symptoms cannot be detected during a quick inspection are listed under point VII.

### General remarks

- It is advisable to clean the tape-deck of the VCR properly before each repair.
  - If, e.g. 11U514→1U701 is indicated, then check the circuit or the connection between these points.
  - If, e.g. it says measure on C-TS1, then the DC-voltage must be measured on this point.
  - If the voltage measured does not deviate more than approx. 20 % from the value stated, it can be considered as good.
- The voltages are measured with a multimeter of 40,000 Ohm/V.
- The figures are added to simplify fault location and to clarify the repair method.

## Principal print panels with components

*Panel 10 - supply*

nrs. 100...199  
plugs P

*Panel 20 - servo*

nrs. 200...299  
plugs A and B

*Panel 32 - timer*

nrs. 320...399  
plugs D

*Panel 50 - front end*

nrs. 500...599  
plugs K and L

*Panel 70 - video*

nrs. 700...799  
plugs F

*Panel 90 - head amplifier*

nrs. 900...999



**CHECKING PROCEDURE**

- . Connect aerial or colour pattern generator to VCR
- . Connect VCR to CTV
- . Connect VCR to the mains (do not switch on)

**I CHECK THAT THE CLOCK IS IN WORKING ORDER**

Does not work:

1-a

**II TUNE CTV TO AERIAL/GENERATOR SIGNAL**  
(when a generator is used, the max. output should be 10 mV)

Weak or no picture:

J-U552 → + 1,  
U552

**III SWITCH ON VCR**

Check threading-in and threading-out

- . Threads out immediately after the "on" key has been released
- . Threads out shortly after threading-in
- . Does not thread in
- . Does not thread out
- . Threads in too slowly
- . Threads in too quickly (clock and lamps light up glaringly)
- . Clock does not function any more after threading-in
- . Tape keeps moving for a while after threading in
- . Does not thread out automatically after about 2 minutes

TS116, TS115, TS112 on supply p.c. board

3-a

Check the threading-in circuit as shown in Fig. VI-1

Check the threading-out circuit as shown in Fig. VI-2

TS101

TS1, TS101, TS103

TS101, TS1

TS121, S3

3-b

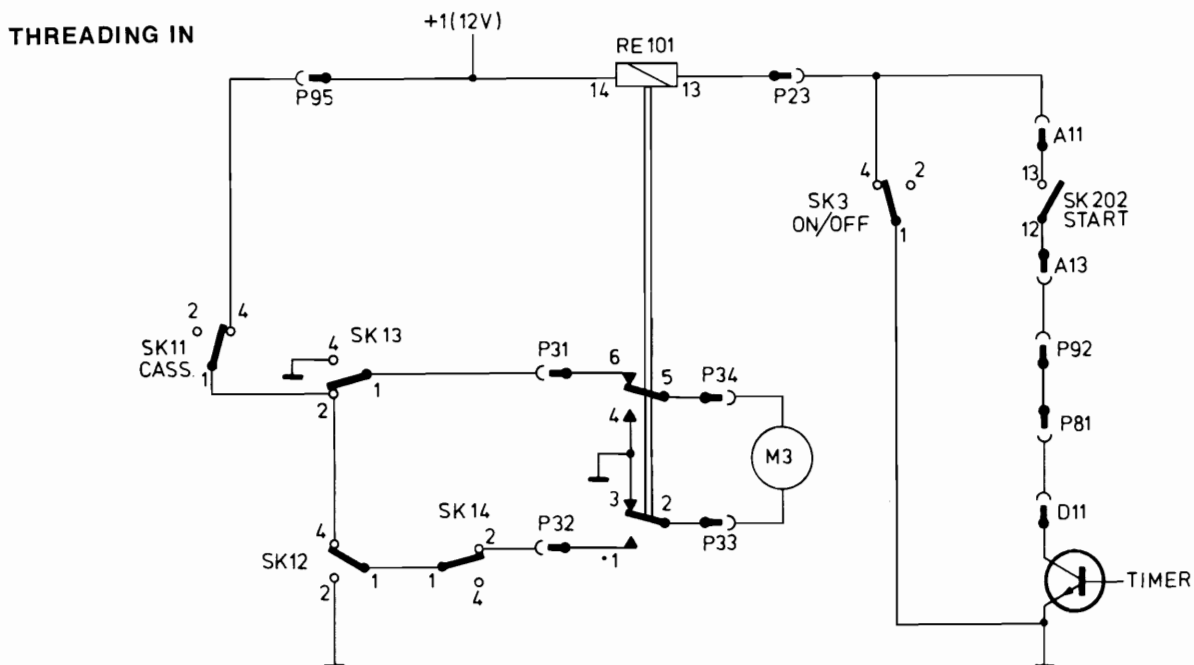

Fig. VI-1

**THREADING OUT**

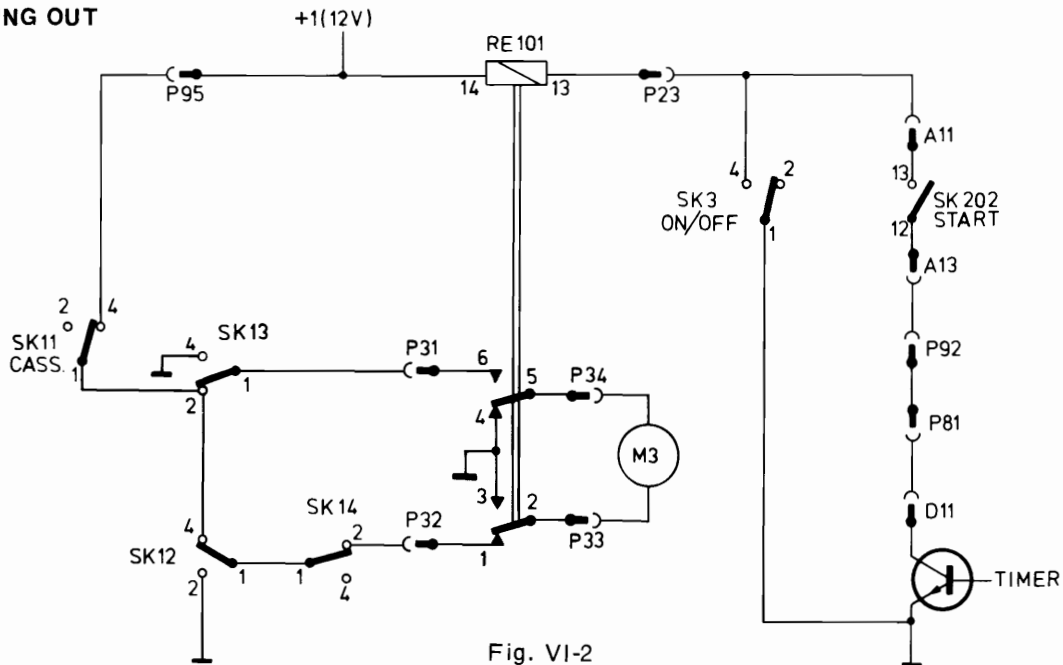

Fig. VI-2

10298A4

**IV INSERTING A PRE MODULATED CASSETTE  
VCR IN POSITION PLAYBACK  
TUNING CTV TO VCR**

- . Picture and sound normal
- . Weak or no picture - Weak or no sound
- . Weak or no picture - Normal sound
- . Poor or no sync - Normal sound
- . Normal picture - Weak, poor or no sound
- . Weak, wrong or no colour
- . Dropouts in picture (disturbing dots or stripes)
- . Tracking does not function properly
- . Unstable picture
- . Unstable sound (wow)
- . Start key does not remain pressed
- . Start key is not released after switching off
- . Threads out immediately after pressing start key
- . Switches off always after about 2 minutes

see V

4-a

4-b

4-b

4-c

4-d

4-e

4-f

4-f

4-f

TS113, TS114, Adjustment of S6

TS114, S5

U218, U216,  
+6 circuit short-circuited ?

TS110

**V VCR IN POSITION "STOP" \***

Check that VCR has been properly tuned (CTV has already been tuned)

- . Normal picture and sound
- . Weak or no picture - Weak or no sound
- . Weak or no picture - Normal sound
- . Normal picture - Weak, poor or no sound
- . Weak or no colour
- . Phaft does not work properly
- . Stop motion does not work properly

see VI

5-a

5-b

5-c

U506, TS503

5-d

SK8, Re8

\* Note:

To avoid that during adjusting or measuring, the VCR always switches off after about 2 minutes, press the wind key or the rewind key (without cassette).



**VI MAKE A RECORDING AND CHECK THE RESULT**

- . No sound during recording
- . Does not record colour
- . Does not record
- . Picture and/or sound unstable
  
- . Threads out immediately

+3 circuit (plug L47)  
 U514, 11U514→1U701  
 U701, TS901...TS903  
 U217, U510  
 Z501, Erase head K5 (about 1 Ω)  
 Plug K21→K5  
 C520, C901,  
 +3 circuit short-circuited ?

**VII MISCELLANEOUS**

- . Switches off during playback and recording at beginning of tape
- . Does not switch off at beginning or end of tape
- . Switches off during playback and/or fast winding after about 2 minutes
- . Does not switch off automatically after about 2 minutes in position "stop"
- . Does not switch off when heads drum and/or tape transport are blocked
- . Tape rotates for a while after threading-in
- . Keys are not released after switching off
- . Stop motion does not work

2-a  
 2-b  
  
 TS110  
  
 3-b  
  
 TS126, TS109  
 2-SK14→ relay S3, TS121  
 TS114, S5  
 SK8, Re8

REPAIR PROCEDURE

**1-a Clock does not work**

- . Do not switch on VCR
- . Measure on plug D12 (+1 on clock p.c. board)



Check clock p.c. board

- . Measure C-TS1 (23 V) on +D102

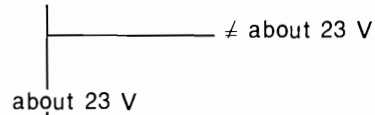

Z102, D102, Z1, T1  
 (if Z1 open, check also D103, D104, D105)

- . Measure E-TS1 (12 V) on 11Re102

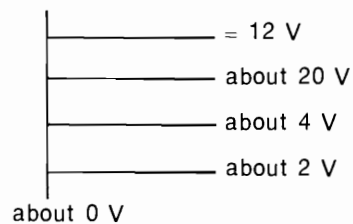

E-TS1 → plug P83 → plug D12  
 TS1, TS101, TS103 (C-E short-circuit)  
 TS101...TS105  
 Z101, D101

- . Measure B-TS1 (E-TS101)

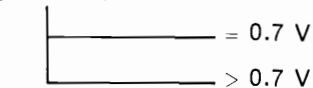

+1 circuit short-circuited  
 TS1

**2-a Switches off at beginning of tape during playback and recording \***

- . Connect B-TS119 to chassis (on supply p.c. board)
- . VCR in position "wind"
- . Measure on plug P13 (SK16)

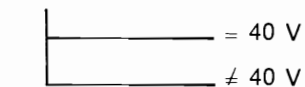

TS119, TS120  
 TS117, TS118

\* Note:  
 After the keys have been pressed in positions playback and recording, they should not be released within 45 seconds by the stop foil on the tape

**2-b Does not switch off at beginning or end of tape**

- . VCR in position "wind"
- . Measure on plug P13 (SK16) on supply p.c. board

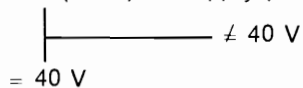

TS119, TS120

- . Short-circuit plug P13 (SK16) for a moment to chassis

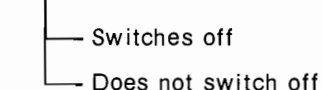

TS117, TS118  
 TS113, TS114, SK16  
 Adjustment of S6, S6



**3-a VCR switches off shortly after threading-in**

- . To avoid that VCR always switches off, block relay S5 (under tracking control) with a piece of thick paper
- . Switch on VCR
- . Check that heads drum and capstan rotate

1. Heads drum rotates - Capstan stops

- . Measure on 3U220 (about 14 V)

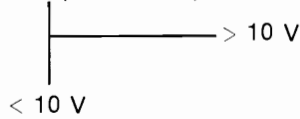

3U220 → M2 (tape motor),  
M2, drive belt

- . Measure on 13U220 (5 V)

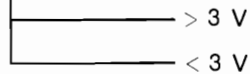

U220, TS202

U218, U216  
C7 (10 μF) in U220

2. Heads drum stops - Capstan rotates

- . Measure on 3U219 (about 14 V)

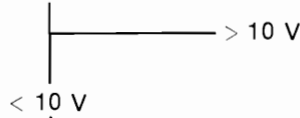

3U219 → M1 (heads motor)  
M1, drive belt

- . Measure on 11U219 (6.6 V)

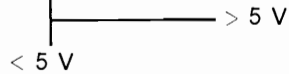

U219, TS201

- . Measure on 10U216 (8.5 V) and on 11U216 (6.5 V)

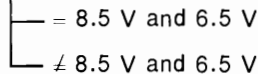

U218, C7 (10 μF) in U219

U216, U513,  
12U216 → 9U513,  
10U513 → + 1 A

3. Heads drum and capstan stop

- . Measure on plug B23 (+7 on servo p.c. board)

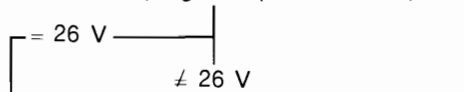

- . Measure on plug P63 (+7 on supply p.c. board)

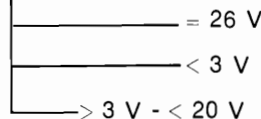

Plug P63 → B23

TS123, R115, +25 circuit short-circuited ?

TS106, TS107,  
TS124, TS125

- . Measure on plug B27 (+10 on servo p.c. board)

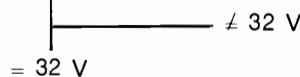

Plug B27 → +10

- . Measure on 3U219 (about 14 V)

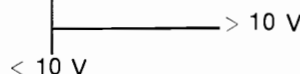

Plug S1 on motor p.c. board

- . Measure on 10U216 (8.5 V) and on 11U216 (6.5 V)

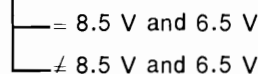

U218

U216, U513  
12U216 → 9U513,  
10U513 → + 1 A

ADAPTED TO FACTORY CODE WD09

**3a** VCR switches off shortly after threading-in

- . Remove cassette
- . To avoid that the VCR always switches off, keep the "on" button in position.
- . Measure on 3-U219 (15 V) and on 3-U221 (9 V)

1. 3U219 = 15 V and 3U221 ≠ 9 V



U221, TS202

2. 3U219 ≠ 15 V and 3U221 = 9 V

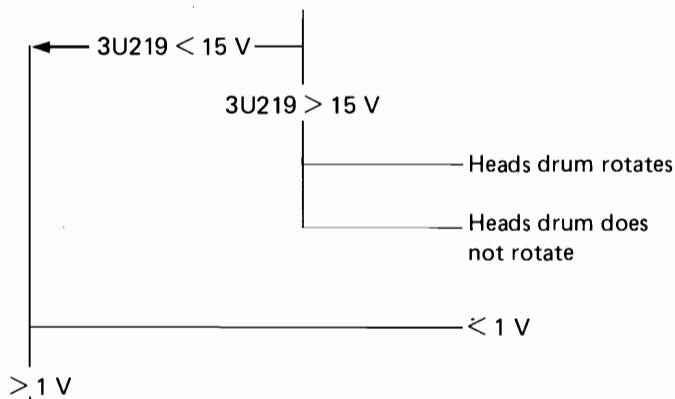

U216, K6 (140 Ω)  
17U216 → K6 →   
Driving belt M1,  
3U219 → M1, Motor M1

U219, TS201  
+ 7 circuit short-circuited?

- . Measure on 10U216 (8.5 V) and on 11U216 (6.5 V)

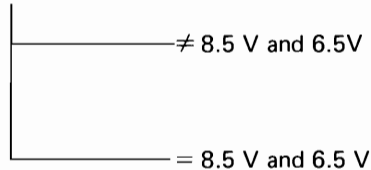

U216, U513,  
12U216 → 9U513,  
10U513 → + 1A

U228, U219  
Plug B23 → Plug P63 (+ 7)  
Check + 7 circuit

3. 3U219 ≠ 15 V and 3U221 ≠ 9 V

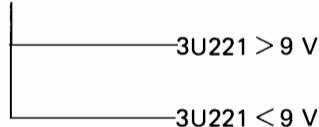

Plug B21 → Plug P62 (+ 1A)  
Plug B25 → Plug S12  
Plug B27 → Plug P64 (+ 10)

4. 3U219 = 15 V and 3U221 = 9 V

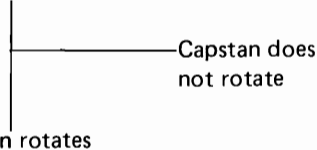

Drive belt M2, Motor M2  
3U221 → M2

- . Keep the start key pressed too, and measure on 3U221 (14 V)

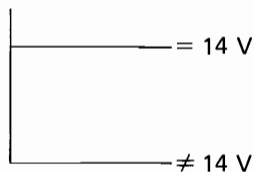

TS109, TS126  
13U227 → TS126  
15U216 → TS109

U227, K7 (140 Ω)  
12U227 → Plug B11



4. Heads drum and capstan rotate

. Measure on 3U219 (about 14 V)

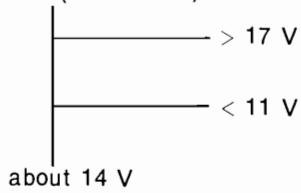

U216, K6 (100 Ω)  
 17U216 → K6, Bearings of heads drum  
 Plug B21 → + 1A,  
 U216, U218

. Measure on 3U220 (about 14 V)

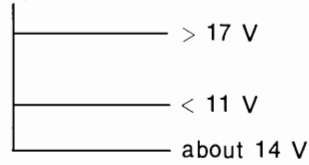

U217, K7 (100 Ω)  
 12U217 → K7, Bearings of flywheel  
 U218, U216  
 TS216, TS109,  
 13U217 → TS126,  
 11U218 → TS109

**3 - b** VCR does not switch off automatically after about 2 minutes in position "stop"

. VCR in position "stop"

. Short-circuit C-E of TS115 on p.c. supply board for a moment

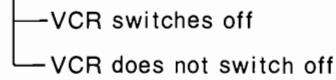

TS111, TS112, TS110  
 TS116, S5

**4-a "PB" Weak or no picture - Weak or no sound**

- . See Fig. VI-3
- . VCR in position "playback" or "stop"
- . Measure on E-U551 (12 V)

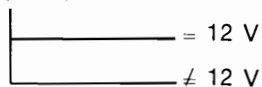

U551  
TS501, TS502

**4-b "PB" Weak or no picture - Normal sound or Poor or no sync.**

- . VCR in position "stop"
- . Tune VCR to colour signal until the luminance and chrominance indicating LED's light up

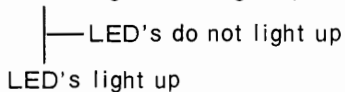

U513

- . Tune CTV to VCR
- . Normal picture
- . No normal picture
- . See Fig. VI-3
- . Measure on 17U511 ( 3 V, ~~2.5 V~~ )

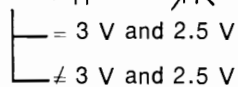

U551  
U511,  
5U511 → 11U511

- . VCR in position "playback"
- . Measure on 3U219 (about 14 V) on servo p.c.board

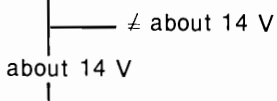

See 4-f (servo)

- . See Fig. VI-4
- . Check luminance circuit between K1/K2 and 6U721

R709 (+ 6 A),  
U702\*, U703, U721\*

- \* Note:
- The units U702 and U721 can also be checked as follows:
- . Remove U702 and/or U721
- . On the p.c. board in the VCR connect 2U702 to 15U702 and/or 3U721 to 7U721
- . Then an acceptable picture must be obtained.

Heads drum (K1-K2)  
TS904...TS906,  
Plugs F21, F42, L52

**4-c "PB" Normal picture - Weak, poor or no sound**

- . See Fig. VI-5
- . VCR in position "stop"
- . Tune VCR to input signal

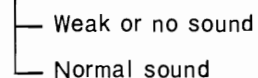

U509  
U510, K3 (about 100 Ω),  
3U510 → K3



VI - 9 I, N1502, N1512

ADAPTED TO FACTORY CODE WD09

# 4-f "P.B." Picture and/or sound instable

- . First clean the VCR
- . VCR in position "Playback" with pre modulated cassette
- . Measure on 3U221 (about 15 V)



U221, TS207, D201...D203,  
D205...D208

- . Measure on 3U219 (about 16 V)

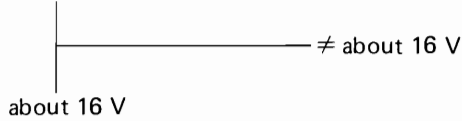

U219, U228

- . Measure on 8U227 (6.5 V and 9.5 V)

With tracking control on minimum  
6.5 V and on maximum 9.5 V

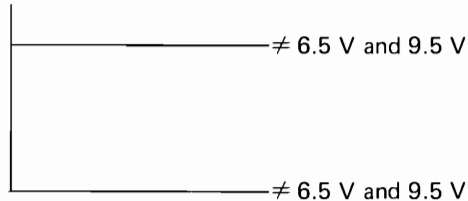

U227, K4, TS203,  
2U227 → R201,  
Tracking control R1  
Check the adjustment of K4

U221, U216, U228  
16U513 → C108

**4-d "PB" Weak, wrong or no colour**

. See Fig. VI-6

. VCR in position "stop"

. Tune VCR to colour signal until chrominance-indicating LED lights up

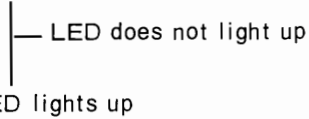

U514E, U515E,  
U512E, U513E

. Tune CTV to VCR

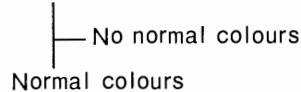

U515E, U512E, U514E

. VCR in position "playback"

. Measure on plug L33 (E-TS702) 5 V

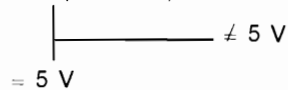

TS701, TS702, Plugs L33, F33

. Measure on plug K44 (16U515E) 9 V

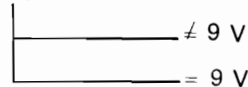

TS504

U515E, U512E

**4-e Dropouts in picture**

. First check that the tape path is clean

U704, U702, TD701  
See Fig. VI-4

**4-f "PB" Picture and/or sound unstable (servo)**

. VCR with pre-modulated cassette in position "playback"

. Measure on 3U219 (about 14 V) and on 3U220 (about 14 V)

1. 3U219 is about 14 V - 3U220 ≠ about 14 V

. Measure on 8U217

Tracking minimum 6.5 V

Tracking maximum 9.5 V

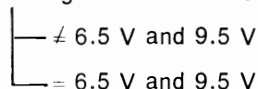

U217, TS203, Check adjustment head K4

U218, K4 (300 Ω), 2U217→ K4, U220

2. 3U219 ≠ about 14 V - 3U220 is about 14 V

U218, U219

3. 3U219 and 3U220 are ≠ about 14 V

U216

4. 3U219 and 3U220 are about 14 V

a. Both voltages are stable

- . Clean VCR and check adjustment tape path
- . Replace successively

Check tracking control R1  
U216, U219, U220

b. Both voltages are unstable

U513  
16U513→ C108

c. Is one of these voltages unstable, first replace unit U219 or U220. If no result, replace U216



**5-a "Stop" Weak or no picture - Weak or no sound**

- . See Fig. VI-3
- . Remove aerial from VCR
- . Remove cassette
- . VCR in position "wind" or "rewind"  
(to avoid that VCR switches off after about 2 minutes)
- . Measure on plug L52 (16U506) 3.5 V

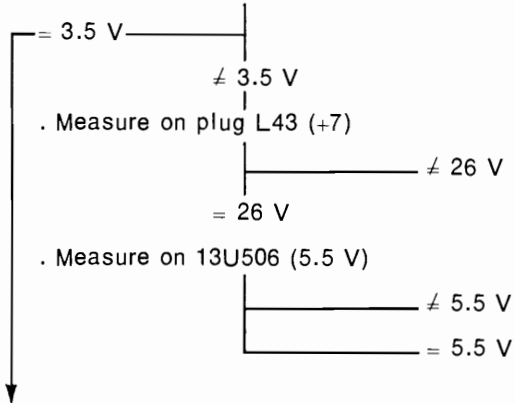

- . Measure on plug L43 (+7)
- . Measure on 13U506 (5.5 V)
- . Measure on 3U505 (4.5 V)
- . Measure on plug L41 (4U508) 33 V

Plug L43 → + 7

SK8 (stop motion), C514  
U506, U507,  
U553 (see voltage table)

U507

Plug L41 → + 8, U508

U506,  
U553 (see voltage table)

**Voltage table  
Tuner U553**

	VHF I	VHF III	UHF
1	<del>X</del> 2.5 V T 3.5 V	<del>X</del> 2.5 V T 3.5 V	0.5 V
2	0-30 V	0-30 V	0-30 V
3	-3 V	11 V	11 V
4	11	10	0.6
5	12	11	0.6
6	12	12	12
8	0	0	0
10	0.5	0.5	11
12	0.5	0.5	11
13	0.4	0.4	<del>X</del> 2.5 T 3.5

**5-b "Stop" Weak or no picture - Normal sound**

- . See Fig. VI-3
- . Replace U506
- If no result:
- . Remove aerial from VCR
- . VCR in position "stop"
- . Measure on 3U505 (4.5 V)

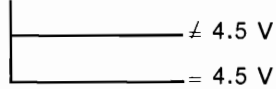

U507, R531  
U505, U553

**5-c "Stop" Normal picture - Weak, poor or no sound**

- . See Fig. VI-5
- . VCR in position "stop"
- . Measure on 17U508 (2.5 V)

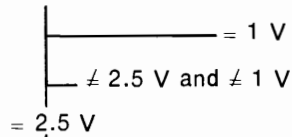

17U508  $\rightarrow$  + 5 (SK504)  
U508

- . Measure on 2U506 (9 V)

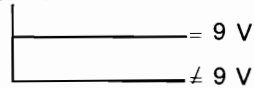

U509, U508, F512 (+4)  
U506

**5-d Phaft does not work properly**

1. No normal sound
2. Normal sound

- . Measure on plug L42 (-9)

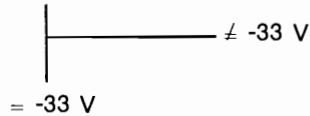

Plug L42  $\rightarrow$  -9 (D107),  
U508

- . Measure on plug L41 (+8)

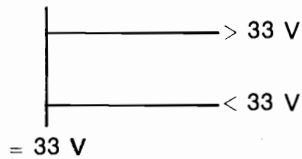

Check TS108 for C-E short-circuit before  
replacing U508  
Plug L41  $\rightarrow$  + 8 (TS108), U508

- . Open drawer U20 (Phaft switched off)

- . Measure on E-TS507 (0.6 V)

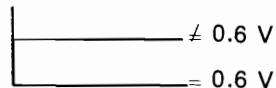

TS507  
U508, D501



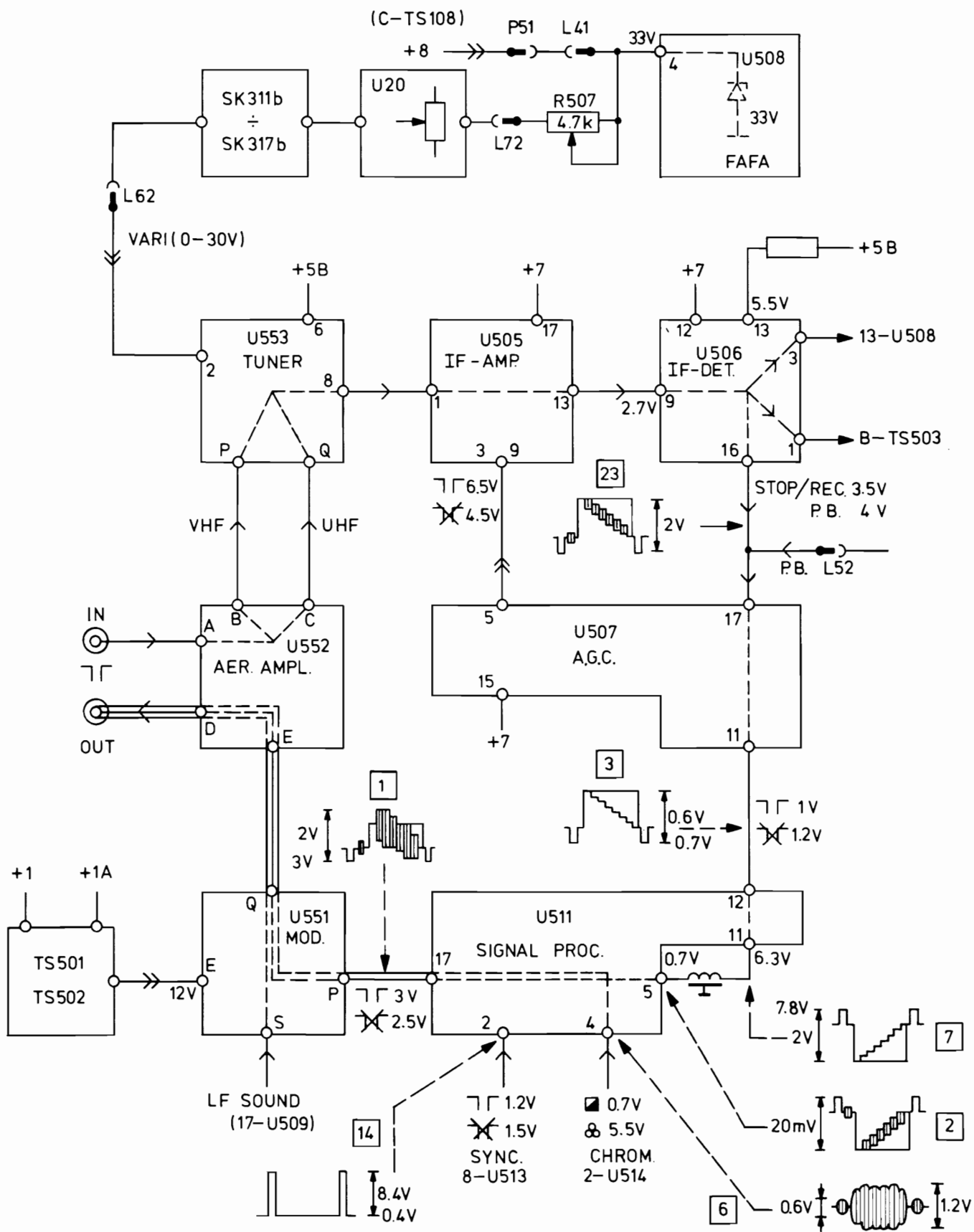
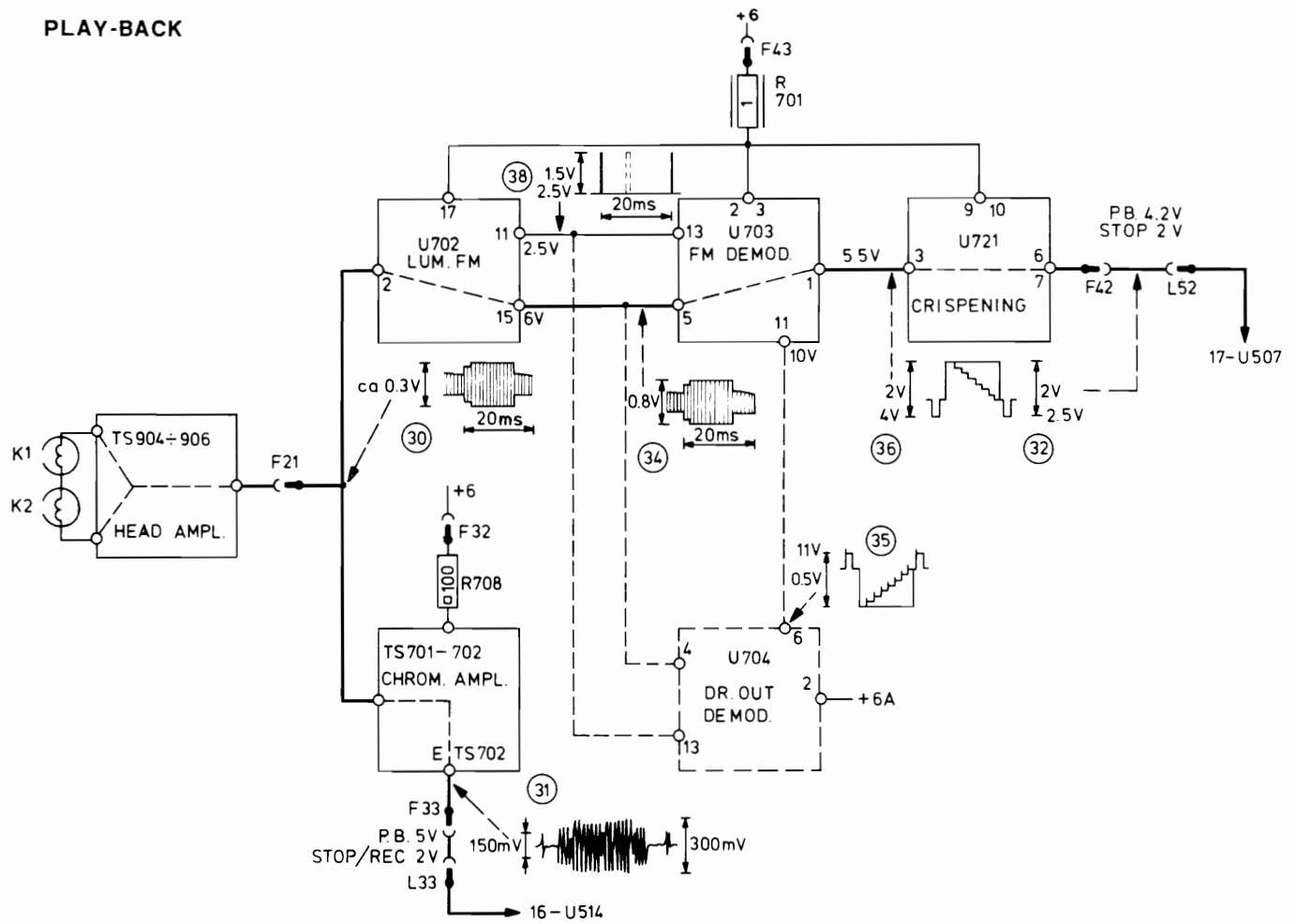

Fig. VI-3

10195 B4

PLAY-BACK



10196 B 4

Fig. VI-4

SOUND PB/STOP

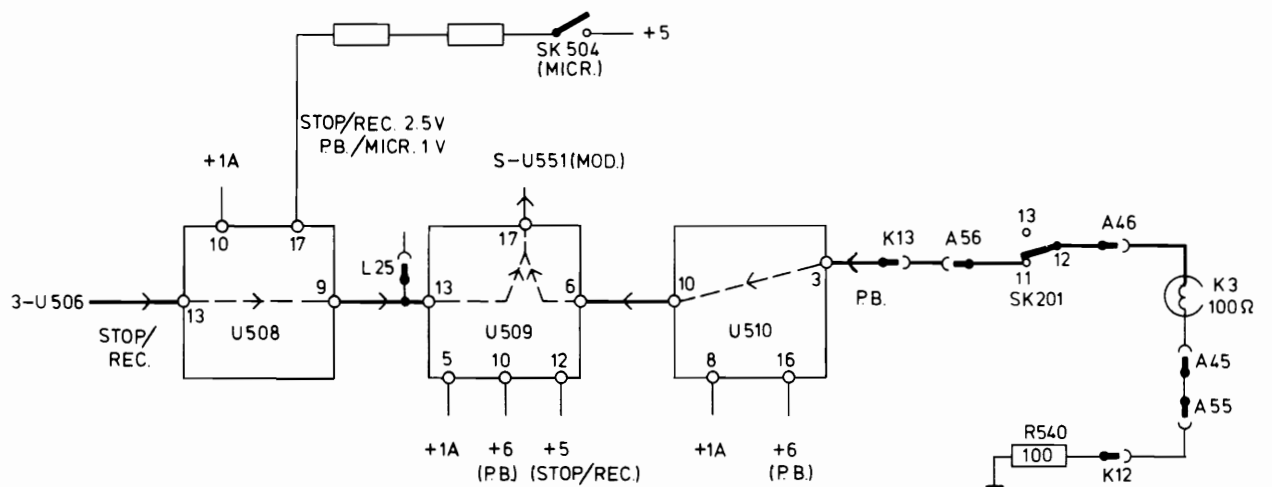

10299 B4

Fig. VI-5





**VII ADDITIONAL SERVICE INFORMATION**

VII A Modifications in diagram A

VII B Modifications in diagram B

VII C Modifications in diagram C

VII D Modifications in diagram D

VII E Modification in the mechanical section



**MODIFICATIONS IN CIRCUIT DIAGRAM A**

	Intr. date	Modification	Reason
1	633	<b>R703</b> changed from 10K to 15K. <b>R706</b> changed from 750E to 330E.	Less chroma noise.
2	639	In /15 and /43 versions, a special <b>U507</b> has been applied from the start of production. Codenummer U507 (for /15 and /43): 4822 210 20259.	Special type, because a higher AGC-voltage was required.
3	WD03/ 641	<b>TS507</b> has been replaced with BC416C or BC556. Added: <b>R523</b> (5.6M) and <b>D516</b> (BZX79/C15). Cancelled: <b>R521</b> <b>N.B.</b> This change has been effected in circuit diagram A already.	a. The PHAFT-pull-in range becomes independent of the selected channel. b. Diminishing PHAFT zero shift during the switch-on delay.
4	642	<b>R507</b> has been cancelled and replaced with a wire bridge.	Adjusting the varicap voltage is superfluous.
	WD05/ 646		
5	647	<b>U511</b> has been changed, so that the VCR identification pulse is widened from 0.4 to 0.5 $\mu$ sec. The new U511 is marked .4.	This change was necessary to ensure switch-over of the time constant of CTV-sets with K12 chassis.
6	648	<b>U507</b> Various components changed. New version is marked .5.	IF-control circuit is now low-ohmic. Adjustment is no longer required. The adjustment range of HF-control was increased, reducing the chance of overdriving the IF-amplifier.
7	649	From the start of production of <b>N1512</b> sets, for TS801 type BC338 has been applied.	This transistor is better resistant to high loads (for instance, if both outputs are connected).
8	WD06/ 650	<b>R170</b> has been changed from 2.2K to 4.7K.	Increased adjustment range of the chroma writing current.
9	702	<b>U506</b> Various components changed. New unit is marked .3. <b>C517</b> has been changed from 68E to 56E.	Reducing the pearlstringstructure of the transients. Cancellation of the extra timedelay of the chroma-signal caused by the new U506.
10	WD07/ 704	<b>R520</b> has been changed from 22K to 56K. Besides, on print 10, <b>R162</b> has been changed from 3.3K to 10K. <b>N.B.</b> These changes have to be effected simultaneously.	Reducing the variation of PHAFT zero adjustment as a result of mains voltage variations. See also sheet VIIC-1 points 5.
11	709	<b>U701</b> changed from .2 to .3.	To reduce frequency drift owing to temperature variations.
12	709	<b>U702</b> changed from .2 to .3.	To prevent oscillation during fill-up of dropouts.
13	709	<b>U513</b> changed from .5 to .6.	Improved operation of the sync separator if signals are not up to standard and/or weak.
14	WD08/ 710	<b>U511</b> changed from .4 to .5.	To reduce the influence of the VCR identification pulse on the stability of the line sync pulses.
15	713	<b>R543</b> (47K) changed to 120K; <b>R544</b> (4.7K) to 3.9K; <b>R545</b> (1.8K) to 1.2K. <b>N.B.</b> Incidentally, this change may also occur in previous sets.	To reduce the influence of the crystal tolerances on the operation of the oscillator.

	Intr. date	Modification	Reason
15	713	<b>R543</b> (47K) changed to 120K; <b>R544</b> (4.7K) to 3.9K; <b>R545</b> (1.8K) to 1.2K. <b>N.B.</b> Incidentally, this change may also occur in previous sets.	To reduce the influence of the crystal tolerances on the operation of the oscillator.
16	711	<b>TS906</b> changed from BF495 to BF494 code 5322 130 44195.	Amplification more efficient.
18	WD10/719 for /15/43	<b>U511</b> has been replaced with 4822 210 20234. <i>Remark:</i> This change is only true for /15/43	The VCR identification pulse causes picture breakdown in some of the G8 CTV-receivers.
19	735	Added: <b>C532</b> - 22 pF <b>D517</b> - BAW62 <b>D518</b> - BAW62 <b>R559</b> - 4,7 kΩ <b>C711</b> - 330 pF <b>R714</b> - 180 Ω <b>R715</b> - 220 Ω <i>Remark:</i> This change is only true for the N1512.	On playback, the luminance signal for the crispening unit is now supplied to the sync separator in U513E, so that the crispening cannot interfere with the line sync pulses. These interferences cause jitter in the sync signal at the output of the sync separator.
20	WD11/750 for /00	<b>U511</b> has been changed from 3103 128 2078.5 to .6. The VCR-identification pulse has been deleted. Under the existing service codenumber 4822 210 20207 only the latest version will be supplied.	The VCR identification pulse occasionally gave rise to synchronisation difficulties.
21	WD11/750 for /00/45  WD12/750 for /15/65 WD12/803 for /43	<b>U508</b> has been changed from 3103 128 2075.4 to .5 The VHF/UHF amplification change-over will be effected in the output amplifier in future. As a result of this change, the following changes had to be carried out to the main signal print and to the supply print:  On print 50: - <b>R509</b> cancelled - <b>R508</b> changed from 12K to 1 Ω (1/8 W - 5%)  On print 10: - <b>R162</b> changed from 10K to 6,2K (1/8 W - 5%)  Service supplies: For the time being, under the existing service code-number 4822 210 20204 the version 3103 128 2075.4 will be supplied. An accompanying letter states what to do if the .5 version is replaced with .4 In future, the .5 version will become available. Also this version will be supplied under code 4822 210 20204. An accompanying letter will state what to do if the .4 version is replaced with .5.  <b>U508</b> has been changed from 3103 128 2094.2 to .3. For a discription of this change, see change U508 for /00/45 above. For the time being, under the existing service code-number 4822 210 20226, the version 3103 128 2094.2 will be supplied. An accompanying letter states what to do if the .3 version is replaced with .2. In future, the .3 version will become available. Also this version will be supplied under code 4822 210 20226. An accompanying letter will state what to do if the .2 version is replaced with .3.	Stabilizing the zero adjustment of the PHAFT control voltage.



	Intr. date	Modification	Reason
22	803	The value of R553 has been changed from 10 kΩ to 18 kΩ.	Improved drive D301.
23	807	TS506 was BC548 has become BC548B.	Improved drive D301.
	WD12 for /00/45 WD13 for /15/43/65	Changed ruler on lower drum.	
24	812	<b>Added on print 80</b> D806 - BAW62 D807 - BAW62 R809 - 22 kΩ - 1/8 W - 5 %  The adapted circuit diagram is shown on page IV-5-3 and the adapted print on page IV-5-4.	To prevent hum and switch-on interferences.
25	WD13 for /00/45 815  WD14 for /15/43/65 815	<b>Added on print 50</b> D517 - BAW62 D518 - BAW62 R559 - 4,7 kΩ - 1/8 W - 5 %  <b>Added on print 70</b> C711 - 330 pF R714 - 360 Ω - 1/4 W - 5 %  <i>Remarks:</i> a. Because of these changes, the tracks of the prints 50 and 70 have been changed. The adapted prints 50 and 70 are shown on page IV-5-4. The adapted circuit diagram A is shown on page IV-5-3. b. This solution cancels the provisional solution, built-in in the N1512 only, see point 19 on page VII A-2a of this chapter. The diagrams of this provisional solution are shown on pages IV-5-1 and 2.	Less jitter in the picture on reproduction of a VCR-signal.  <b>Explanation:</b> By the crispening unit U721 the sync pulses of the luminance signal reproduced were slightly distorted. This distortion caused jitter in the separated synchronisation signal at 8U513E. From now on, the luminance signal which, on reproduction, is supplied to the sync separator in U513E, is not taken any longer via the crispening unit, but directly at the output of U703.
26		The chrominance units U514E and U515E have been replaced with U514 and U515, code numbers 4822 210 20253 and 4822 210 20254 resp.  Because the oscillator in U515 is based on a fundamental frequency of 8,86 MHz, crystal KT502 has been replaced with a 8,86 MHz version, code 4822 242 70252.  Because of the application of the 8,86 MHz crystal, capacitor C530 has been deleted.  - The adapted circuit diagram is shown on page IV-5-3 and the adapted print on page IV-5-4. - The service adjustments of U514 and U515 are mentioned on the pages III-5a and III-7a.	The units U514 and U515 are more reliable.  <i>Remark:</i> Unit U514E is not interchangeable with U514, neither U515E with U515. Pairwise exchange (U514E,U515E) with U514,U515 is possible. However, also crystal KT502 must then be exchanged. And if U514E and U515E are fitted, C530 has to be mounted again.
27		Added a parallel circuit S508, C528 between 16U506 and 17U507. Code number S508: 4822 156 20765.	Standardization with respect to prints of other types of apparatus.
28		The connecting points of S504 and S505 are wrongly shown in the first issues of circuit diagram A. These connecting points are shown correctly on page IV-5-3.	

**MODIFICATION IN CIRCUIT DIAGRAM B**

	Intr. date	Modification	Reason
1	WD01/639	<b>U217</b> changed from .2 to .3. <b>R204</b> has been changed from 8K2 to 330E. Added: <b>R213</b> (1.8K) between A62 and A63.	a. Ensuring that the VCR is not switched-off if double pulses are present on the tape (for instance, at the beginning of the tape). b. Exacter zero-adjustment of the tracking control when playing back own recordings.
2	WD05/646	Added: <b>C205</b> (10 nF) between points 12 and 13 of U217.	Suppressing mains interference in the tape servo.
3	WD06/650	<b>U217</b> changed from .3 to .4.	Increasing the amplification, so that the sync pulse at MP B33 is increased to 7-8 Vpp.
4	652	Added: <b>Wire bridge</b> between point 4 and 19 of SK201 (see Service Manual). <b>N.B.</b> In the service imprint on panel 20 points 15 and 9 of SK201.	During playback, +12 applied to point 17 U217, to ensure that interference pulses from point 17 do not interfere the tape servo.
5	702	<b>U216</b> : version changed. This change is not marked by a change of the issue number. The changed units of the 1976 production are marked with a red line. In 1977 only the changed version has been produced.	Improved interference suppression to ensure that the head disc cannot be synchronized at half-speed.
6	703	<b>R401</b> and <b>R402</b> have been changed into safety resistors, code 4822 111 30343.	Safety
7	WD08/710	Added: <b>D201</b> -/ <b>D208</b> (BAW62); <b>D209</b> (BZX79/C6V8); <b>TS206</b> (BC337); <b>R209</b> (5.6K); <b>R210</b> (100K); <b>R211</b> (8.2K); <b>R212</b> (5.6K)	To limit the speed of the tape transport motor during thread-in and in STOP position, to prevent the tape from being damaged (see also VIIC-1a pt. 9 and VIIE-1a pt. 10).
8	WD08/710	Added: <b>R214</b> (4.7K); <b>R215</b> (2.7K); <b>R216</b> (10K) Changed: <b>R204</b> (820E) to 330E, <b>R213</b> (6.8K) to 2.2K.	More accurate zero setting of the tracking control on playback of own recordings.
9	713	U219 version changed to .3.	Better 25 Hz suppression, so that compensation adjustment is less critical.
10	WD09/716	U217 has been replaced with <b>U227</b> U218 has been replaced with <b>U228</b> U220 has been replaced with <b>U221</b> Deleted: <b>D204</b> , <b>D208</b> , <b>D209</b> , <b>R209</b> and <b>R210</b> . Point 13 of U221 is connected to point 13 of U227, U217 can replace U227 and continues to be available under code 4822 210 20218. Codenummer U221: 4822 210 20274	The speed discriminator in U221 provides that the tape speed variations during recording and playback do not exceed 10% of the nominal speed. <i>Note:</i> If VCRs up to WD09 are rebuilt, it is sufficient to replace U220 with U221, to remove the wire bridge between point 13 of U220 and junction D204, D209 and the wire bridge between point 2 of U218 and point 13 of U220 and to fit a wire bridge between point 13 of U217 and point 13 of U221.
11	718	Added: <b>TS207</b> - BC548B <b>D208</b> - BAW62 <b>D209</b> - BZY88/C3V3 code 5322 130 30392 <b>R217</b> - 4,7 kΩ	Improved fast-winding after the introduction of U221.
12	750	Added: <b>C120</b> (100 pF - 63 V ceramic) between the base and collector of TS207. <b>D210</b> (BAW62) between the base and emitter of TS207. The cathode of D210 is connected to the base of TS207.	Prevents oscillations of the output stage of the tape servo.



	Intr. date	Modification	Reason
13	809	The factory code of U221 has been changed from 3103 128 2134.2 into .3.	Improved quality (new IC)
14	843	The factory code of <b>U227</b> has been changed from 3103 128 2088.3 into .4. <b>TS203</b> has been changed from BC548 into BC548C. Added <b>C207</b> (18 nF) between point 17 of SK201 and mass.	To increase the sync amplitude during recording

**MODIFICATIONS IN CIRCUIT DIAGRAM C**

	<b>Intr. date</b>	<b>Modification</b>	<b>Reason</b>
1	635	<b>D116</b> (BAW62) changed to BY206.	Better resistant to interference pulses of the threading-in motor.
2	635	<b>R134</b> is connected to +1A instead of +1.	Ensures that the unlocking magnets do not attract twice when the set is switched-off.
3	WD02/ 640	Added: <b>R175</b> (1E) in series with D120. <b>R176</b> (1E) in series with D115. Codenummer 1E safety: 4822 111 30215.	Protection against short-circuit of C116 and D112 resp.
4	WD04/ 643	In /15 versions, transformer T1 has been changed to .3. For the primary winding another kind of wire has been used and extra insulation for VL1 has been applied. <b>N.B.</b> Later on, this change will also be effected in other versions.	Safety demands Great-Britain.
5	WD07/ 704	<b>R162</b> has been changed from 3.3K to 10K. Besides, on print 50, <b>R520</b> has been changed from 22K to 56K. <b>N.B.</b> These changes have to be effected simultaneously.	Reducing the variation of the PHAFT-zero adjustment as a result of mains voltage variations. See also sheet VIIA-1a pt. 10.
6	WD08/ 710	<b>C130</b> (4.7n) changed to 10n.	As a result, the switch-off mechanism comes into operation at lower speed of the capstan, so that undesired switch-off (for instance at the beginning of the tape) is prevented.
7	WD08/ 710	<b>R133</b> (22K) changed to 2.2K. <b>R134</b> (4.7K) changed to 390E.	More reliable functioning of the 2 minute delay circuit.
8	WD08/ 710	Added: <b>VL103</b> (1AT - 4822 253 30021) <b>R177</b> (1 ΩS - 4822 111 30215)	To protect the mains transformer from short-circuit.
9	WD08/ 710	Added: <b>SK9</b> and <b>SK10</b> ; <b>TS122</b> (BF245B) <b>R163</b> to <b>R166</b> incl., <b>D126</b> (BZX79/C9V1)	To limit the speed of the tape transport motor during thread-in and in STOP position, to prevent the tape from being damaged (see also VIIB-1a pt. 9 and VIIE-1a pt. 10).
10	710	<b>D104</b> , <b>D105</b> , <b>D107</b> and <b>D108</b> changed from BY126 to BY226 code 4822 130 41119.	Supply failures of BY126.
11	710	Added: <b>R178</b> (1 kΩ 1/8 - 5% ) between point 1 of RE101 and junction R165, R166.	Protection of TS122.
12	710	Added: <b>R179</b> (100 kΩ, 1/8 W- 5% ) between the + pole of C102a and mass.	C102a can now be discharged via R179 on switch-off of the VCR.
13	750	<b>R162</b> (10K) has been changed to 6,2K. Remark: This change has been effected simultaneously with the changed U508.	More current through the zener diode in U508.



**MODIFICATIONS IN CIRCUIT DIAGRAM D**

	Intr. date	Modification	Reason:
1	637	50 Hz reference signal is applied to bTS326 instead of bTS327.	Preventing the LED's from flashing during clock-setting
2	WD02/640	R332 has been changed from 1K to 1,8K	The decimal point will now light up when the battery voltage has decreased to approx. 8,3 V. At this voltage, the circuit performance is reliable under all circumstances.
3	WD08712	R325 changed from 39K to 120K R326 changed from 22K to 150K R330 has been deleted R331 changed from 10K to 100K R332 changed from 1,8K to 1,5K R347 changed from 4,7K to 33K R357 changed from 510 Ω to 560 Ω TS324 changed from BC548 to BC548C All resistors are standard 1/8 W-5%. Codenummer BC548C: 5322 130 44196.	Reducing the leakage current in the battery.
4	WD09/720 for /00 and /45 WD10/720 for /15, /43	R325 changed from 120K to 82K R357 changed from 560 Ω to 510 Ω	Adaptation to the tolerances of the current amplification of TS324.

**MODIFICATIONS IN THE MECHANICAL SECTION**

	Intr. date	Modification	Reason
1	630	Between pins 531 and the bracket on which audio sync. head K3-K4 is mounted, 3 rings item 35 have been added.	Facilitating the height adjustment of the audio sync. head.
2	635	a. The spring pressure of spring 237 has been reduced. Under the existing code number 4822 492 40634 the new spring is supplied. b. Spring 198 has been replaced with a spring with smaller pulling force. Codenumber new version spring 198: 4822 492 31369.	a. Reducing the force for depressing the fast winding keys, so, less pressure on brackets 295 and 538.  a+b Reducing the starting jerk.
3	635 638	a. Bracket 295 has been provided with riveted reinforcement on the tag (provisional solution). b. Bracket 295 has been provided with a riveted pin (definite solution). Under existing codenumber 4822 403 50901 the new bracket 295 with riveted pin is supplied, together with spring 273. c. Bracket 538 has been provided with a riveted pin instead of the tag. This new bracket 538 is now supplied as bracket 305, under code number 4822 403 50988.	a+b Working of the rewind-function is more reliable.  c. Ditto, for the wind-function. <b>Remark:</b> Owing to non-availability of material, the provisional solution has been applied to sets with serial numbers 1002521 -/- 1003470 and 1004823 -/- 1005244. The definite solution has been effected in sets with the serial numbers 1004301 -/- 1004822 and from 1005245.
4	WD02/ 640	Added: PVC-ring 43 between brackets 244/525 and 245/525 resp. The nose of bracket 525 is slightly bent downward.	Better functioning of bracket 525, does not get stuck.
	WD05/ 646		
5	647	Clamp 238 has been slightly changed: spring 237 is now fixed by 2 clamps 238. Under the existing codenumber 4822 532 20657 the changed clamp 238 is supplied.	Less friction of spring 237.
6	649	Ring 37 above upper reel disc 218 has been replaced with a knurled ring code 4822 530 80183.	Securing screw 9 in reel disc 218.
7	WD07/ 704	a. Cassette lift cover 100 has been changed; the new version fits on old sets, the old version does not fit on new sets. Under the existing codenumber 4822 443 10053 the new cover will be supplied, but without lens. This lens, item 100A, is available under code 4822 450 60142. b. Cover plate 101 now has an oblong centring hole on the left hand side; the changed version fits on old sets, the old version does not fit on new sets. Under the existing codenumber 4822 443 20085 the new cover plate is supplied. c. Frame 102 now has a centring pin 4x7 mm on the left hand side. The centre of the frame is fixed from above with selftapper item 21, which is accessible through a hole that becomes visible if the REC-key is depressed. <b>Screw 134</b> has consequently been cancelled. The changed frame 102 does not fit on old sets and is available under code 4822 443 50264. The old version remains available under existing code-number 4822 443 50248.	a to f incl. Moulds of the cabinet parts have been changed. c + d. To facilitate the mounting of the cover by means of the fixing screw at the top.



VIIE-2a, N1502, N1512

Intr. date	Modification	Reason	
7	cont'-d.	<p>d. <b>Bottom 113</b> has been changed. The hole, through which screw 134 was mounted has been cancelled; instead, there is a hole for screw 21 (fixing frame 102, see 7c). The changed bottom 113 does not fit without more on old sets; the new version is available under code 4822 443 50265.</p> <p>The old version is supplied under existing code-number 4822 443 50251. Once the old stock is exhausted, the new bottom can be used together with the new bracket 131 (see also 7e), and the new batterydrawer 133 (see also 7f).</p> <p>e. <b>Bracket 131</b> has been changed. This new version is available under code 4822 404 60116. The old bracket fits on old sets only and is available under existing codenumber 4822 403 50896.</p> <p>f. <b>Battery drawer 133</b> has been changed to hold now 1 battery only. The convex centring boss has temporarily been changed to an ob-long boss. This new battery drawer also fits in the old bottom 113, provided that the recess in the bottom of the above centring boss is slightly filed off.</p> <p>Under the existing codenumber 4822 443 60518 the changed battery drawer is supplied.</p>	
8	705	<p>On the two pins on the chassis, underneath strip 251, <b>circlip item 46</b> - 4822 530 70166 - has been added.</p>	Better positioning of strip 251.
9	708	<p>Panel 20 is fixed with <b>clamp 304</b> instead of with screw 13. Codenumber clamp 304: 4822 401 10634.</p> <p><b>Bracket 547</b> has been cancelled; spindles 535 and 536 are now fixed with two circlips item 30 each.</p>	Fixing of panel 20 made simpler.
10	WD08/ 710	<p>Added: <b>brackets 272A, 273A and 274A</b>. Codenumber 272A - 4822 403 51001 Codenumber 273A - 4822 492 51182 Codenumber 274A - 4822 492 62058</p>	Introduction of SK9 and SK10 (see also VIIB-1 pt. 7 and VIIC-1 pt. 9)
11	710	<p>Added: <b>ball 194A</b> between adjusting screw 14 and pulley 195. Codenumber ball 194A: 4822 520 40037.</p>	Fixing pulley 195 improved.
12	712	<p><b>Lampholder 226</b> has been changed and <b>bracket 511</b> replaced with a plastic bracket 226A, deleting bush 510. Codenumber new lampholder: 4822 380 20081. Codenumber bracket 226A: 4822 403 51008.</p>	Unreliable mounting of bush 510.

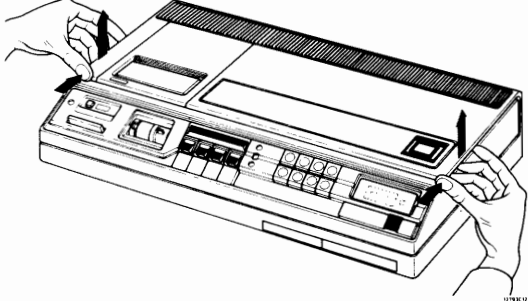
Intr. date	Modification	Reason
13 714	<p>In the <b>lower reel disc 221</b> the aluminium bearing bushes have been replaced with sintered bronze bushes. As a consequence, the diameter of the bush has been changed from 12 to 10 mm, and therefore also the <b>rings item 26, 219....225</b>.</p> <p>The <b>bending pipe</b> for adjusting the reel disc spindle bearing, which is usable for both 10 and 12 mm, is available under codenumber 4822 395 90097.</p> <p>Codenumber new reel disc 221 - 4822 528 10318.</p> <p>Codenumber new ring 224 - 4822 532 10715.</p> <p>Codenumber new circlip 26 - 4822 530 70028.</p> <p>Codenumber set of 5 new rings 219, 220, 222, 223, 225 - 4822 310 30414.</p>	Improved quality.
14 715	<p>The <b>hinge bracket of panel 10</b> has been changed. <b>Strip 553</b> (mains flex relief) is now fitted with one screw 2 in the said bracket and one self-tapper 47 in the bottom.</p> <p>Codenumber self-tapper 47: 4822 502 84012.</p>	The chassis is fixed to the bottom at 3 points, reducing the chance of chassis distortion.
15 725	<p><b>Cover plate 101</b> has been provided with snap locks on either corner at the front.</p> 	<p>Improved cover fixing.</p> <p><i>Note:</i> For demounting the cover plate, turn loose the screws 113 and 130, push this plate backwards by pushing the two corners simultaneously upwards and backwards.</p>
WD09/716		
WD10/719	Only for /15, /43	
16 WD10/729 for /00 and /45 WD11/729 for /15/43	<p>The <b>mounting of the erase head K5</b> has been changed, the bush on the chassis has been deleted.</p> <p>Added: <b>Bracket 548</b> <b>Spring 251A</b> - 4822 492 62106 <b>Tension spring 251B</b> - 4822 492 31016 <b>Screw</b> - 4822 505 10569</p>	Improved mounting of erase head K5.
17	<p>Added: <b>Reinforcement plate 549</b></p> <p>This plate is fitted with 6 screws 48 and the two cassette roller spindles. The thread of the cassette roller spindles has been lengthened to 10 mm. These spindles continue to be available under the existing code. .</p> <p>Codenumber screw 48: 4822 502 10693.</p>	Reinforcement of the chassis. Tape-threading more stable.

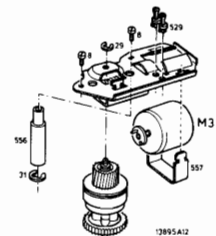

	Intr. date	Modification	Reason
18	WD11/ 750 for /00 and /45 WD12/ 750 for /15 and /43	<p>The <b>threading-mechanism</b> has been changed completely.                      New codenumber:  <b>Plate + worm:</b> 4822 691 20088  <b>Gear:</b> 4822 522 10142  <b>Threading motor M3:</b> 4822 361 20143</p>	<p>Improvement - less noise during threading.</p> 
19	749	<p>The lower drum, at the spot of tape inlet and outlet (near cams O and R); has been fitted with extra plastic tape guides.</p>	<p>Improved tape-guiding.  <i>Remark:</i>                      During the dynamic tape lace-up adjustment, the auxiliary tape-guide near cam R must be removed.</p>
20	WD12 for /00/45 809 WD13 for /15/43/65 809	<p>The <b>ruler on the lower drum</b> has been changed. Codenumber of lower drum with changed ruler: 4822 528 80682.                      The <b>stop of bracket 242</b> has been changed. The changed bracket can also be used for old apparatus.                      Added: plastic drum stop slid over the stop tag on the chassis.</p>	<p>The angle at which the tape is wound round the lower drum had been decreased by 1,5°, diminishing the chance of overlapping.</p>
21	815	<p>Control and fitting of SK9 and SK10 have been changed:                      Codenumber:  <b>Slide 273C:</b> 4822 278 90339  <b>Tension spring 273B:</b> 4822 492 30611</p>	<p>To improve the reliable operation of SK9 and SK10.</p>
22	837	<p>The soldered joint of the mains flex has been changed into a plug connection. For this, the bracket in which panel 10 hinges, has been fitted with an adapter and a mains input socket (BU1). This socket is accessible via a hole in housing 113.                      Under the existing code the changed housing is supplied. The hole for the mains plug is covered by a removable plate, so that this housing can be used for either old or new apparatus.                      Codenumbers:  <b>Adapter:</b> 4822 263 50065  <b>BU1:</b> 4822 265 20169  <b>Mains flex for /00:</b> 4822 321 10183  <b>Mains flex for /15:</b> 4822 321 10184  <b>Mains flex for /43:</b> 4822 321 10185</p>	
23	837	<p>The complete <b>pressure roller bracket 282</b> has been changed.                      As a consequence the following parts have been modified or added:                      269A, 269B, 275B, 279A, 280A, 282B, 285A, 286A, 287A and the audio/sync head, see the adapted exploded view and parts list.</p>	<p>Simplified azimuth, height and east/west adjustment of the audio/sync head.                      For the modified adjustments see page III- 17.</p>





# Service Information

1976-11-16

VIDEO CASSETTE RECORDER N1502

VR76-06

Correction Service Manual page III-13a, III-14a, III-15a and III-16a

# Service Information

1977-02-07

VIDEO CASSETTE RECORDER N1502

VR77-01

Already published: VR76-06

## CONTENTS:

Replacement sheet	VII-1a
Supplementary sheets	VIIA-1
	VII B-1
	VII C-1
	VII D-1
	VII E-1

## Remark:

In future, information about video cassette recorder N1502 will consist of supplementary and/or replacement sheets for the documentation. Replacement sheets will have a subsequent small letter behind the sheet number, supplementary sheets will have a subsequent figure behind the sheet number.

Changes in the N1502 recorders will be mentioned in chapter VII, classed per diagram A-B-C or D, or the mechanical section E.

To this purpose, chapter VII is subdivided in VII A, VII B, VII C, VII D, and VII E.

The changes are listed in the sequence of the introduction dates.



# Service Information



**PHILIPS**

1977-05-16

VIDEO CASSETTE RECORDER N1502

VR77-05

Already published: VR76-06  
VR77-01

**Contents of VR77-05:**

Supplementary sheets: IV-7-1  
IV-7-2  
IV-9-1  
IV-9-2  
IV-15  
IV-16  
V-4-1  
VIIIE-2

Replacement sheets: II-21a  
II-22a  
IV-7a  
IV-8a  
IV-9a  
IV-10a  
IV-11a  
IV-12a  
V-3a  
V-5a  
V-6a  
V-7a  
V-8a  
V-9a  
VIIIA-1a  
VIIB-1a  
VIIC-1a  
VIIIE-1a

# Service Information

1977-09-19

VIDEO CASSETTE RECORDER N1502

VR77-10



## PHILIPS

Already published: VR76-06, VR77-01, VR77-05

### Contents of VR77-10

Supplement sheets:      IV-5 I  
                                 IV-5 II  
                                 IV-7 III  
                                 IV-7 IV  
                                 VIIE-3  
                                 VIIE-4

Replacement sheets:    II-17a  
                                 II-18a  
                                 II-21b  
                                 II-22b  
                                 IV-5a  
                                 IV-6a  
                                 IV-7 IIa  
                                 IV-8b  
                                 V-4 Ia  
                                 V-4 IIa  
                                 V-5b  
                                 V-6b  
                                 V-7b  
                                 V-8b  
                                 VIIA-1b  
                                 VIIA-2  
                                 VIIB-1b  
                                 VIIC-1b  
                                 VIID-1a  
                                 VIIE-1b  
                                 VIIE-2a  
                                 VIIE-3



# Service Information

1977-10-17

VIDEO CASSETTE RECORDER N1502

VR77-14

Already published: VR76-06, VR77-01, VR77-05 and VR77-10

Reeds verschenen: VR77-02, VR77-06 en VR77-11

## Contents of VR77-14:

Supplementary pages : IV-17

## Inhoud van VR77-14

Toevoegingsbladen: IV-17

### Explanation:

The Service Information Bulletins about Video recorders consist of the yellow front page and of one or more replacement pages and/or supplementary pages.

The yellow front page surveys the supplementary pages and/or replacement pages.

Supplementary pages are denoted by a Roman figure behind the page number. If these supplementary pages are added to a chapter, these pages are numbered consecutively.

Replacement pages are denoted by a small letter behind the page number.

Example: Page V - 4 I b

This is the replacement page of V-4 I a

Page V - 4 I a was the replacement page of V-4 I

Page V - 4 I was an additional page behind

page V - 4.

### Toelichting

Service mededelingen betrekking hebbende op video-recorders bestaan, behalve uit het gele frontblad, uit een of meerdere vervangings- en/of toevoegingsbladen.

Het gele frontblad vermeldt een opsomming van de toevoegings- en/of vervangingsbladen.

Toevoegingsbladen krijgen een romeins cijfer achter het bladzijde nummer. Indien deze achter een hoofdstuk worden toegevoegd worden deze bladen doorgenummerd.

Vervangingsbladen krijgen een kleine letter achter het bladzijde nummer.

Voorbeeld: Blad V-4 I b

Dit is het vervangingsblad van V - 4 I a.

Blad V - 4 I a was het vervangingsblad van V - 4 I

Blad V - 4 I was een toevoegingsblad achter blad V - 4.

Déjà publié: VR77-04- VR77-08 et VR77-13

Bereits veröffentlicht: VR77-03, VR77-07 und VR77-12

## Index de la VR77-14

Feuillets supplément: IV-17

## Inhalt von VR77-14

Ergänzungsblätter: IV-17

### Explication

Les Info Service traitant des magnétoscopes se composent non seulement d'une feuille de couverture jaune, mais aussi d'une ou de plusieurs feuillets-supplément et/ou de remplacement.

La feuille de couverture jaune présente une énumération des feuillets supplément et/ou de remplacement.

Les feuillets-supplément sont reconnaissables au chiffre romain figurant derrière le numéro de la page. Si ces feuillets sont ajoutés à un chapitre, la numérotation sera pour suivie.

Les feuilles de remplacement sont identifiables à la lettre minuscule figurant à la suite du numéro de la page.

Exemple: P. V - 4 I b

Il s'agit de la feuille de remplacement de

V - 4 I a

P. V - 4 I a est la feuille de remplacement de

V - 4 I.

P. V - 4 I est un feuillet-supplément à la suite de la p. V-4.

### Erläuterung

Service-Mitteilungen über Videorecordern bestehen - ausser der gelben Frontpagina - aus einem oder mehreren Ersatz- und/oder Ergänzungsblätter.

Die gelbe Frontpagina gibt eine übersicht über die Ergänzungs- und/oder Zusatzblätter.

Ergänzungsblätter werden mit einer römischen Ziffer hinter der Blattnummer bezeichnet.

Wenn diese Blätter hinter einem Kapitel hinzugefügt werden, werden sie durchnummeriert.

Ersatzblätter werden mit einem kleinen Buchstaben hinter der Blattnummer bezeichnet.

Beispiel: Blatt V - 4 I b

Dies ist das Ersatzblatt von V - 4 I a

Blatt V - 4 I a war das Ersatzblatt von V - 4 I

Blatt V - 4 I war ein Zusatzblatt hinter Blatt V-4.

# Service Information

1978-02-20

VIDEO CASSETTE RECORDER N1502

VR78-07



## PHILIPS

Already published: VR76-06, VR77-01, VR77-05, VR77-10, VR77-14

### Contents of VR78-07:

Supplement sheet : VII E-4

Replacement sheets: VII A-2a  
VII B-1c  
VII C-1c

# Service Information

1978-02-24

VIDEO CASSETTE RECORDER N1502

VR78-15

Already published: VR76-06, VR77-01, VR77-05,  
VR77-10, VR77-14, VR78-07

## Contents of VR78-15

Supplement sheets: VI - 7 I  
VI - 9 I



# Service Information

1978-06-01

VIDEO CASSETTE RECORDER N1502, N1512

VR78-24



## PHILIPS

Already published: VR76-06, VR77-01, VR77-05, VR77-10,  
VR77-14, VR78-07, VR78-15

### Contents of VR78-24

Supplement sheets: IV-5-3  
IV-5-4  
VII A-3  
VII B-2

Replacement sheets: III-3a  
III-5a  
III-6a  
III-7a  
VII E-4a

# Service Information

1979-02-28

VIDEO CASSETTE RECORDER N1502, N1512

VR79-01

Already published: VR76-06, VR77-01, VR77-05, VR77-10  
VR77-14, VR78-07, VR78-15, VR78-24

## Contents of VR79-01

Supplement sheets: III - 17  
V - 4 III  
VII E - 5

Replacement sheets: V - 5c  
V - 6c  
V - 7c  
V - 9b  
VII B - 2a  
VII E - 4b

**Would you please replace page IV-5 II/IV-6a by this page**



(ADAPTED TO FACTORYCODE WD11,N1512) WIRING DIAGRAM A

R	505	513	508	509	501	510	511	530	506	531	502	507	503	533	518	517	522	519	544	514	549	515	542	545	550	553	556	551	558	555	554	
C					510	501	510	502		508	518	507	517	505	509	504	526	521	525	516	546	541	540	552	559	530	530	531				
TS					507																											
MISC	BU2	D503	D506	D502	D516	U552	U508	D501	D513	U511	5504	D508	S502	T0501	S501	D517	BU3	KT501	U513	U509	KT502	D514	U515	BU504	VL501	U512	D510	D512	D519	U514	SK504	D511

IV-5-II, N1502, N1512

