

Service
Service
Service

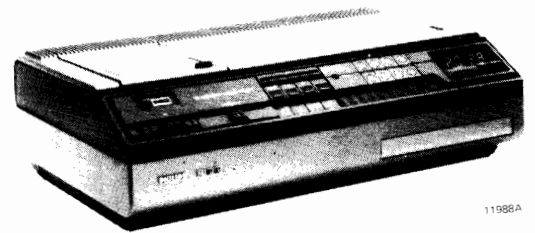

Service Manual

N1700/00 Is a video cassette recorder with TV-receiver section and electronic timer, suitable for recording and playback of TV-signals according to the CCIR-PAL standard. The signals are registered on tape according to the VCR Long Play standard.

N1700/15 Is the same as the /00 version.
N1702/15 However, the HF reception and modulator section is adapted to PAL-A.I. (sound carrier with respect to picture carrier + 6 MHz).
The mains voltage required is 240 V.

N1700/43 Is the same as the /00 version.
N1702/43 However, the HF reception and modulator section is adapted to PAL-A.I. (sound carrier with respect to picture carrier +6 MHz).
The built-in channel selector is adapted to extended band III.

N1700/45 Is the same as the /00 version.
N1702/45 The built in channel selector is adapted to low and high VHF band.

N1700/65 Is the same as the /15 version however for 220 V.
N1702/65

CONTENTS

- I Controls, connections and technical data
- II Description
- III Service adjustments and lubricating instructions
- IV Circuit and wiring diagrams
- V Exploded views and service spare parts
- VI Additional Service Information
- VII Repair Method

Safety regulations require that the set be restored to its original condition and that parts which are identical with those specified, be used.

Documentation Technique Service Dokumentation Documentazione di Servizio Huolto-Ohje Manual de Servicio Manual de Servicio



CS 63 735



Subject to modification
4822 726 12028
Printed in The Netherlands

PHILIPS

I. CONTROLS, CONNECTIONS AND TECHNICAL DATA

CONTENTS

	Page
Controls	I-2
Connections	I-2
Technical data	I-3

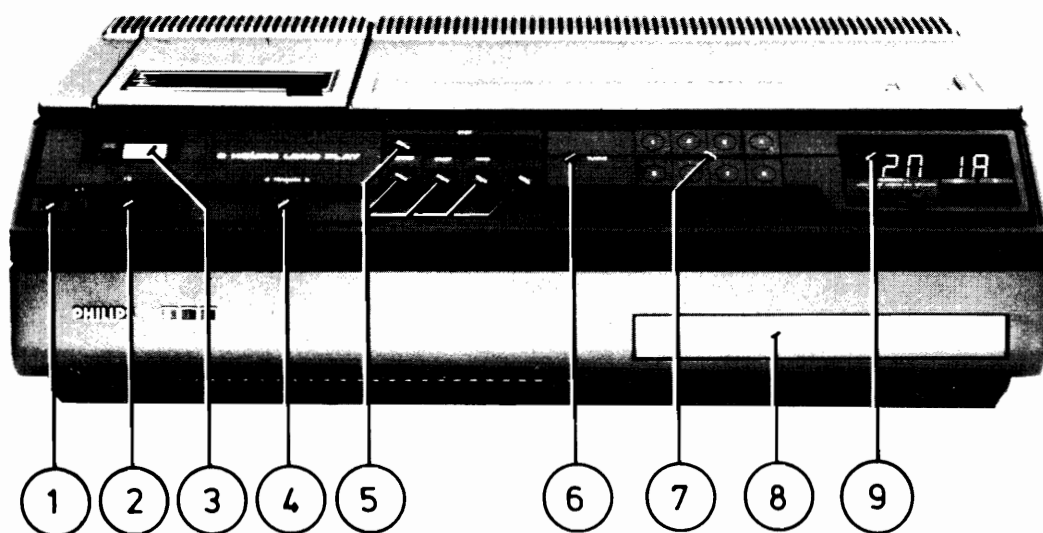

Fig. 1

11998A12

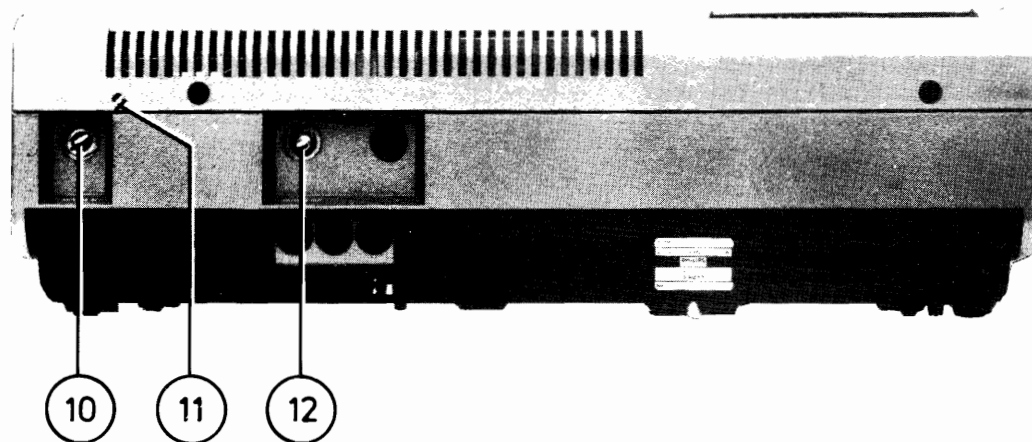

Fig. 2

11999A12

- | | | | |
|---|--|----|--|
| 1 | Indication lamp on/off | 8 | Pre-selection tuning knobs for the eight channels |
| 2 | On/off switch, also for threading-in/threading-out the tape | 9 | Electronic clock, which may also be programmed for automatic start and stop of recording or playback |
| 3 | Programme indicator | 10 | Aerial input |
| 4 | Tracking control | 11 | Opening for detuning the transmitter, using an isolated screwdriver of 2 mm |
| 5 | Control keys of the mechanism, such as fast wind/rewind, recording, play-back and stop. | 12 | Aerial output |
| 6 | Tuning indication (LED) | | |
| 7 | Channel selector push buttons (8 off). When using button nr. 8, phase automatic fine tuning (Phaft) is switched-off. | | |

SPECIFICATION

System

Twin head helical scan. Tape width 1/2 inch. Tape is spooled on two concentric reels and contained in a cassette.
 Tape speed: 6.56 cm/sec.
 Tape-to-head speed: 8.1 m/sec.

Head drum

Diameter 105 mm.
 Rotation synchronised to field frequency.

Cassette loading

Cassette is inserted into an angled opened holder which is tilted down to engage in the recorder. Tape threading is automatic when the VCR is switched to ON.

- Playing time** Up to 2 hours 10 mins. available
- Recorder cabinet** Moulded top cover (grey) and base (black)
- Dimensions** 56x37x16 cm
- Weight** Approx. 16 kg
- Power requirements** 220 or 240 V \pm 10 %
 50 Hz \pm 1 % (only slow drift tolerable)
 50 Watts (8 W when switched off)
- Position for use** Horizontal (max. 15° tilt)
- Ambient temperature** + 15/+35° C

Tuner

- Ranges:
- N1700/00 Band I,III,IV and V (PAL, system B.G.)
- N1700/15 Band I,III,IV and V (PAL, system A.I.)
- N1700/43 Band III,IV and V (extended band III) (PAL system A.I.)
- N1700/45 Low and high VHF,UHF (PAL,system B.G.)
- Aerial input Coaxial socket (DIN 45325) input impedance: 75 Ω
- Automatic fine tuning Switched off when selector button is completely depressed.

Modulator

- Aerial output Socket coaxial plug acc. to DIN45325, impedance: 75 Ω
- Feed through gain (aerial signal) Band I and III: 2 \pm 2 dB
 Band IV and V: 0 \pm 2 dB
- Transmitter frequency (adjustable) Channel 32-42
- Sound modulation FM

Video

- Signal-to-noise ratio Luminance > 40 dB
- Visible resolution at playback colour Luminance 3.0 MHz
 Chrominance 650 kHz

Audio

- Frequency response 120 Hz...10 kHz within 8 dB
- Wow and flutter < 0.3 % (DIN45507) (for own recording)
- Signal-to-noise ratio > 40 dB (weighted, DIN45405)
- Erase oscillator Approx. 60 kHz
- Erase damping > 60 dB

CIRCUIT DESCRIPTIONS

	Page
1. Signal	(circuit diagram A) II-2
2. Servo	(circuit diagram B) II-19
3. Supply - Control and Protection	(circuit diagram C) II-22
4. Electronic Timer	(circuit diagram D) II-27

1. SIGNAL

1.1. INTRODUCTION

The N1700 conforms to the VCR long-play standard. The VCR long-play standard is based on the 2 heads helical scan principle. The tape is wound round a drum to produce a 180° Helical wrap.

The drum consists of two parts, one fixed and one rotating. On the rotating part (head disc) 2 video heads are located, mounted at about 180° with respect to each other. In sequence, these heads scan the tape diagonally (Fig. II-1).

The speed of the head disc is 25 rps. The time of one revolution is 40 m/s, half a revolution takes 20 m/s. Because a TV-frame also takes 20 m/s, it follows that on every revolution each video head modulates just one frame on the tape.

1.2. BASIC DATA VCR LONG-PLAY SYSTEM

1.2.1. Mechanical basic data

Drum diameter	: 105 mm
Speed head disc	: 1.500 rpm
Scanning speed (relative speed video head/tape)	: 8.1 m/sec
Tape speed	: 6.56 cm/sec
Gap length of the video head	: 0.6 μm
Video track width	: 85 μm
Distance between 2 video tracks	: 0 μm
Audio track width	: 0.7 mm
Sync. track width	: 0.7 mm

In Fig. II-1 is schematically shown where the video tracks, the audio track and the sync track are modulated on the tape. Also visible in this figure is the relation between the spot where the frame pulse is modulated on the tape and the position of the picture gap on playback.

The sync track determines the place of the video tracks on the tape.

These 25 Hz pulses are modulated on the tape in the form of needle pulses.

In the VCR long-play system, the video tracks are modulated on the tape against each other. On playback it is inevitable that the video heads also scan parts of the adjacent tracks from time to time.

To ensure adequate track separation, the air gaps of the two video heads do not have a vertical position with respect to the written track. For video head 1 the deviation is 15° (clockwise), for head 2 it is likewise 15° but counter clockwise (Fig. II-1 top right).

Consequently, the air gaps are at an angle of $2 \times 15 = 30^\circ$.

If, on playback, video head 1 scans the track that has been written by video head 2, it has the same effect as if this track should be read by a video head having a much greater gap length. As a result, the playback of especially the high frequencies is attenuated. The angle of 30° is so chosen that adequate track separation is effected.

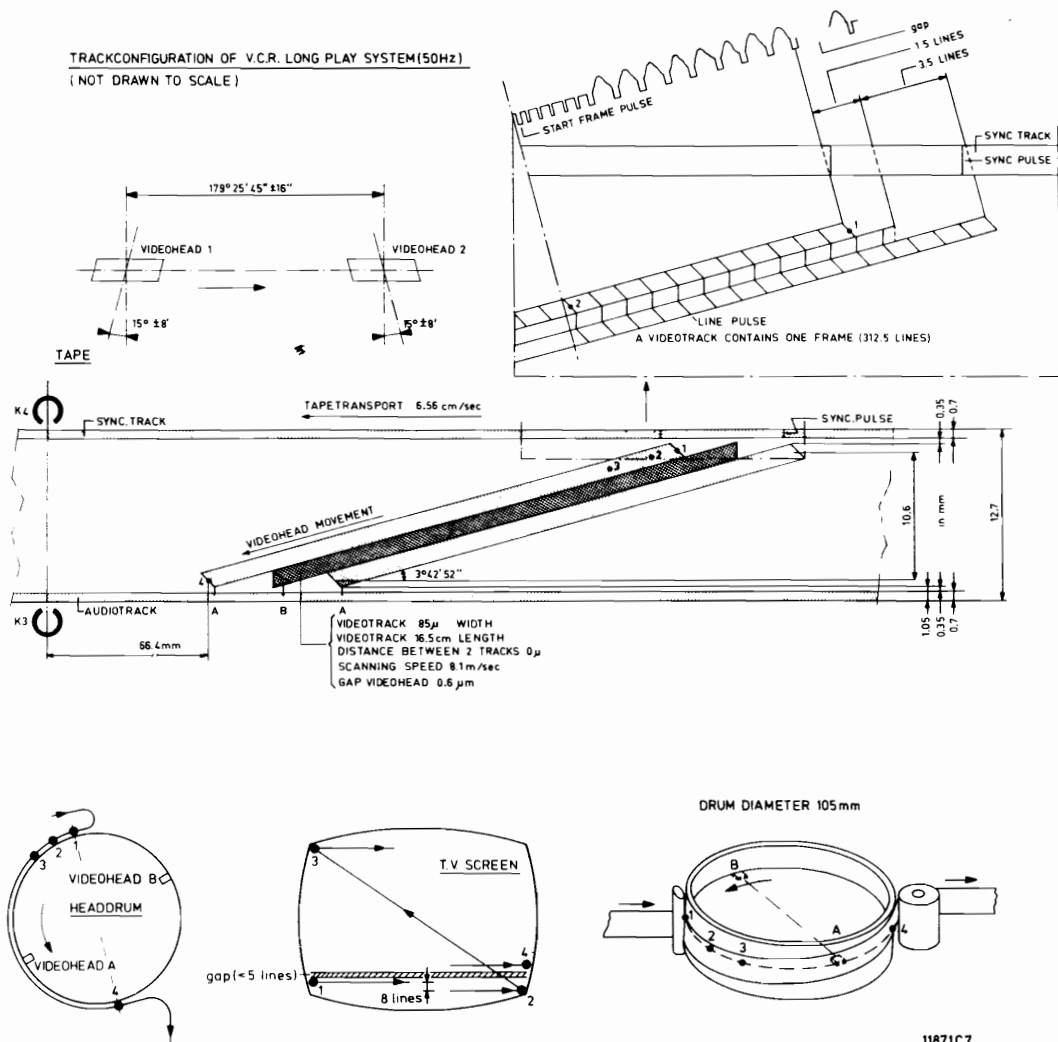

Fig. II-1

1.2.2. Modulation system

The VCR modulation diagram is shown in Fig. II-2. Explained in the following text is how this modulation diagram was made:

- The highest frequency the video heads can playback at the given scanning speed of 8.1 m/sec is approx. 5 MHz.
- With a view to the picture quality, the luminance signal is converted into an FM signal.
- To obtain sufficient signal/noise ratio on demodulation of the FM-signal, the FM sweep must be abt. 1.5 MHz.
- When recording, to avoid interferences, no video signals with a frequency higher than the lowest frequency of the FM-carrier (3.3 MHz) may be fed to the FM-modulator.

From the above, it follows that the chrominance signal must be modulated on the tape via another way.

- The FM sidebands in the frequency range between 0 and 1 MHz are not so important for the luminance signal. This offers the possibility of placing the chrominance signal in this frequency range. By means of mixing, the chrominance signal is transposed to this frequency range.
- The amplitude of the luminance signal modulated in FM is much greater than the amplitude of the transposed chrominance signal. As a result, the FM signal functions as premagnetization signal for the chrominance signal.

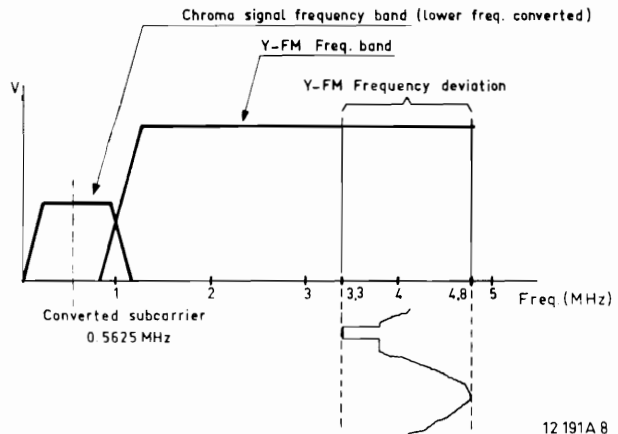

Fig. II-2

1.3. DESCRIPTION OF THE BLOCK DIAGRAM

1.3.1. Introduction

Prior to describing the circuit diagram of the signal section (diagram A), a simplified block diagram of the recording and playback section will be discussed. Above the blocks, unit numbers are mentioned.

These numbers refer to units in circuit diagram A, in which the relevant block (function) is applied.

The blocks that are hatched, function in recording and playback position.

1.3.2. Recording (Fig. II-3)

The aerial signal, applied to input BU2, is fed to aerial amplifier U552.

After the first stage of amplification in this unit, this aerial signal is split and fed to the combined VHF/UHF tuner and after a second stage of amplification it is fed to the output socket BU3 via a combining network. With drawer (panel 34) the channel selector is pre-selected. The 8 selector push buttons are located on panel 31.

Via the IF amplifier U505 the signal of the transmitter selected is fed to the detector unit U506.

This unit produces the detected luminance and chrominance signal and the 5.5 MHz IF sound signal.

○ *Luminance*

The luminance signal is applied to the FM modulator in U731 via a low-pass filter in U507 and an amplifier in U531. By means of this low-pass filter, the signal is limited to a bandwidth of 3 MHz. In the FM modulator the luminance signal is converted into a FM signal. The sweep is 1.5 MHz and lies in the frequency spectrum between 3.3-4.8 MHz (Fig. II-2).

In an adder circuit in U731, the FM luminance signal and the 562.5 kHz AM chrominance signal - to be described later on - are added together and then applied to the video heads K1, K2 via the writing current amplifier on p.c. board 91 and the rotating transformer S1, S2.

○ *Chrominance*

The 4.43 chrominance signal, on recording, must be transposed to a lower frequency range (0-1 MHz). This is done by a mixer in U515. The 4.43 MHz chrominance signal from the detector unit U506 and a 4.99 MHz oscillator signal artificially obtained, are applied to this mixer.

On the output of the mixer the desired 4.996119 MHz - 4.433619 MHz = 0.5625 MHz chrominance signal is filtered out, using a low-pass in U514.

As discussed already, the 562.5 kHz chrominance signal is added to the luminance signal modulated in FM, in U731.

○ *4.99 MHz oscillator signal*

As described earlier, the 4.99 MHz oscillator signal is required for transposing the 4.43 MHz chrominance signal to a lower frequency range.

The 4.99 MHz signal is obtained by mixing an oscillator signal of 562.5 kHz with an oscillator signal of 4.43 MHz in a second mixer in U515.

The sum of these 2 signals is the 4.99 MHz signal required.

The 562.5 kHz signal is supplied by a 562.5 kHz oscillator in U512E. The frequency of this oscillator is controlled by a phase discriminator, to which the line sync pulses of the luminance signal are applied.

The 4.43 MHz signal is produced by a 1:2 dividing of the signal of an 8.86 MHz local oscillator. The frequency of this oscillator is controlled by a phase discriminator to which the burst frequency of the chrominance signal is supplied as reference.

It follows from the above that the 4.99 MHz signal is coupled with the line frequency and with the burst frequency of the transmitter signal, ensuring great stability of the 4.99 MHz signal.

○ *Sound*

The 5.5 MHz IF sound signal (6 MHz for /15/43) is filtered by S504 and then amplified and demodulated by U508.

The audio signal is supplied to the audio recording head via the recording amplifier with automatic recording level control in U539 and transformer S507. With this transformer, the bias signal is added to the audio signal. As usual, the bias signal is supplied by the erase oscillator.

○ *UHF modulator*

In order to check, whilst recording, to which channel the channel selector is tuned, the detected luminance and chrominance signals are applied to the UHF modulator U551 via an adder circuit in U531. Also the modulated sound signal is applied to the UHF modulator. These three signals are modulated on an RF carrier (approx. channel 37) and, just like the aerial signal, supplied to the aerial output BU3 via the combining unit in the aerial amplifier U552.

1.3.3. Playback (Fig. II-4)

In playback position, the signal, induced in the video heads K1, K2 is applied to the preamplifier (on p.c. board 91) via the rotating transformer S1, S2. After the preamplifier, the signal is applied to a high-pass and a low-pass filter.

○ *Luminance*

After the high-pass filter in U732, only the FM luminance signal remains. Next, the FM signal is demodulated in U734.

○ *Drop-out compensator*

The drop-out compensator ensures that drop-outs, i.e. short signal interruptions, are filled up. This is effected by an electronic switch in U734, a 64 μ s delay line and the drop-out detector in U732.

When a drop-out occurs in the signal produced, it will be recognized by the drop-out detector in U732.

This drop-out detector supplies a pulse, so that the electronic switch in U734 changes over. The signal at the output of the limiter in U734 is then supplied back again to the input of U734, via the 64 μ s delay line. Thus, the drop-out is filled up by the information of the preceding line. As in most cases the information of 2 subsequent lines will practically be the same, the drop-out will be invisible.

Because the electronic switch in U734 remains changed over as long as the drop-out occurs, also drop-outs longer than 64 μ s are filled up, because the last line produced correctly is repeated again and again.

In the low-pass filter in U507 all frequencies higher than the luminance playback range (3 MHz) are suppressed.

Next, the luminance signal is applied to the adder circuit in U531.

○ *Chrominance*

After the low-pass filter S703, S704, C702-C707 only the 562.5 kHz chroma signal remains. By means of the mixer in U515 this signal is transposed again to the original 4.43 MHz with the help of the 4.99 MHz oscillator signal which is also present on playback. Via the 4.43 MHz band-pass filter in U515, in which the other mix products are suppressed, the 4.43 MHz chrominance signal is likewise supplied to the adder circuit in U531.

○ *4.99 MHz oscillator signal*

In playback position, the 4.99 MHz oscillator signal is obtained in the same way as in the recording position. Now, the line pulses of the playback/luminance signal are supplied as reference to the phase discriminator controlling the 562.5 oscillator. In playback position, the 4.43 oscillator is free running. Using the mixing method described above ensures that, independent of speed variations of the video disc, a stable 4.43 MHz carrier for the chroma is obtained.

This is explained as follows:

As it is known, the relative scanning speed is not constant, but will always vary slightly.

The frequency of the playback signal proportionally co-varies to the same degree.

Assuming that the scanning speed is 1 % too high, then the frequency of the colour sub carrier induced in the video heads will also be 1 % higher and will be $562.5 \text{ kHz} + 1 \% = 562.500 \text{ Hz} + 5.625 \text{ Hz}$.

Because the 562.5 kHz oscillator in U512E is driven by the line pulses of the playback luminance signal, this oscillator also starts oscillating at a frequency 1 % higher. The oscillator frequency is then $562.500 \text{ Hz} + 5.625 \text{ Hz}$. After mixing with the 4.43 oscillator signal, the 4.99 MHz oscillator signal is also increased by 5.625 Hz. The mix product difference between chrominance and oscillator signal after the mixer in U514E then is $(4.99 \text{ MHz} + 5.625 \text{ Hz}) - (562.5 \text{ kHz} + 5.625 \text{ Hz}) = 4.43 \text{ MHz}$.

It follows that, independent of the variations in scanning speed, there is always a chrominance signal with a stable 4.43 MHz carrier available on the output of the mixer in U515. The deviation of the free-running frequency of the 4.43 MHz oscillator TS504 with respect to the exact burst frequency is not compensated for, and this deviation must be accepted by the subcarrier oscillator in the TV-set connected.

○ *Sound*

The audio signal induced in the audio head K3, on playback, is amplified in unit U539., and then applied to the 5.5 MHz audio modulator in U551.

○ *Modulator*

In the modulator U551 the composite luminance and chrominance signals together with the sound signal (which has been FM modulated onto a 5.5 MHz carrier) are modulated onto a RF carrier (channel 37) and, next, applied to the aerial output BU3 via the combining circuit in U552.

In the N1700/00/43, also the aerial signal on BU2 is applied to the aerial output BU3 via the aerial amplifier.

1.4. DESCRIPTION OF THE CIRCUIT DIAGRAM OF THE SIGNAL SECTION IN RECORDING POSITION

1.4.1. Introduction

In circuit diagram A the main signal paths in recording position are marked with a solid, violet line. The dotted, violet/green line marks the main signal paths common to recording and playback.

1.4.2. Aerial amplifier U552

The aerial signal is applied to the aerial amplifier U552 via BU2. Before the signal is applied to the first amplification stage, all frequencies under band I are suppressed by a high-pass filter. The second filter suppresses the FM band. The aerial signal is applied to the aerial output BU3 via a splitter, a second amplifier and an aerial signal combining circuit.

The loop gain for band I and III is 2 ± 2 dB and for band IV and V 0 ± 2 dB.

After the first splitter the signal is applied to the VHF input via a low-pass filter and to the UHF input of the channel selector U553 via a high-pass filter.

1.4.3. Channel selector U553

U553 is a combined VHF/UHF channel selector with varicap tuning and electronic band switching.

Bands:

- /00/15 version (ELC2000)

Band I	47-88 MHz
Band III	174-230 MHz
Bands IV, V	470-862 MHz

- /43 version (ELC2070)

Band III	174-254 MHz
Bands IV, V	470-862 MHz

The VHF section of the channel selector contains an RF gain controlled amplifier, a separate oscillator and a mixing stage. The UHF section contains an RF gain controlled amplifier and a self-oscillating mixing stage. Moreover, in UHF position, the VHF mixing stage functions as an amplifier.

The collector of this amplification stage contains a tuned IF circuit, across which the IF signal is disconnected in a capacitive manner.

The switching over of the channel selector to VHF position (band I or III) and to UHF position (band IV and V) is effected by feeding supply voltage to the relevant tuner connections. From the plug connection L63 (+5A), this supply voltage is applied to the channel selector via the contacts of SK311a to SK317a incl. and the TV band switches SK341 to SK348 incl. on panel 34.

The diodes D503-D506, in combination with the band switch, take care that, in the band switch position selected, the supply voltage required is applied to the relevant channel selector connections:

In VHF position (band I) points 1, 4 and 5

In VHF position (band III) points 1, 3, 4 and 5

In UHF position (bands IV, V) points 3, 10, 12, 13

In both VHF and UHF position, the tuning voltage is applied to point 2 of the channel selector.

The main tuning voltage is applied to point 2 from the +8, via plug connection L72-G32, one of the 8 potentiometers in drawer panel 34, the channel selector switches SK311b-SK317b, plug connection L62 and R504.

The Phaft voltage for automatic tuning is likewise applied to U553 point 2, via R505. For the description of the automatic tuning, see chapter 1.4.7.

1.4.4. IF amplifier U505

The IF signal is applied to U505 point 1.

This unit contains a combination of filters and a 2-stage gain controlled amplifier. The combination of filters mainly serve for the selectivity of the IF section.

The filter combination gives the following suppressions:

31.9 MHz in /00 version	adjacent sound carrier
30.9 MHz in /15/43 version	carrier
33.4 MHz in /00 version	sound carrier wave proper
32.8 MHz in /15/43 version	wave proper
40.4 MHz in /00 version	adjacent sound carrier VHF
40.9 MHz in /15/43 version	carrier VHF
41.4 MHz in /00 version	adjacent sound carrier UHF
41.5 MHz in /15/43 version	carrier UHF

Suppression is effected before the gain controlled amplifier, to prevent cross-modulation. The two-stage amplifier is forward gain controlled.

The control voltage is applied to points 3 and 9 of the unit. The control range is 40 dB. Capacitor C507 is a smoothing capacitor for the supply voltage.

1.4.5. IF detector U506

The IF detector supplies the following signals:

- On point 16 the detected luminance signal
- On point 1 the detected chrominance signal
- On point 3 the 5.5 MHz (intercarrier) IF sound signal

The IF signal applied to U506 point 9 is amplified once again. Next, it is applied to the luminance and chrominance detector.

○ Luminance detector

Before the signal is applied to the luminance detector, the 33.4 MHz is once again specially limited, to ensure that the sound carrier will not cause any interference in the detected luminance signal. Moreover, this circuit is necessary for obtaining the Phaft automatic tuning voltage in U508. The detected luminance signal is applied to U506 point 11 via an emitter follower. The amplitude of the luminance signal on 16U506 is determined by the external DC-voltage on 13U506. This DC-voltage is produced by voltage divider R530/R531.

○ Chrominance detector

Chrominance detection is carried out by the base emitter junction of a transistor. From the collector of this transistor, the detected chrominance signal is applied to U506 point 1.

○ IF sound

Because of the non-linear characteristic of the base-emitter transition of the chrominance detector, between the 38.9 MHz picture and the 33.4 MHz sound carrier, various mix products occur. The difference between these 38.9 and 33.4 MHz (5.5 MHz) is used as IF sound signal. This signal is available on 3U506.

1.4.6. AGC U507

○ *IF + RF AGC*

To prevent the RF amplifiers in the channel selector and the IF amplifier in U505 from being overdriven, a control voltage must be applied to these amplifiers, dependent on the amplitude of the aerial signal.

This control must also ensure that the amplitude of the detected luminance signal on 16U506 remains constant.

○ *IF - AGC*

The luminance signal on the detector output 16U506 is applied to 17U507. The amplitude of the sync pulses in the luminance signal is a reference for the amplitude of the transmitter signal. These sync pulses are rectified by a top detector in U507. The DC-voltage thus obtained (control voltage) is applied to U505 points 3 and 9, via 5U507.

○ *RF - AGC*

The RF AGC comes into operation only, when the IF AGC is not sufficient any more. Via U507 point 1 and diode D507 a control voltage is then applied to the RF amplifier in the VHF section of the channel selector and, via diode D502, to the RF amplifier in the UHF section of the channel selector.

1.4.7. IF sound + Automatic tuning unit U508

○ *IF sound*

The 5.5 MHz IF sound signal, as discussed already, is available on 3U506. In the 5.5 MHz filter S504 the signal is filtered once again and then applied to U508 points 13 and 12. In this unit, the signal is amplified, limited and next, via an electronic switch, applied to an FM detector. The detected sound is available on 9U508. The electronic switch is opened when 17U508 is not supplied with voltage. This is the case in playback position: the +5 supply voltage is not present then, so that no noise signals can be supplied to the audio playback amplifier in U539 via U508.

○ *Phaft (Phase automatic fine tuning)*

U508 also contains the Phaft detector.

Introduction: The Phaft detector supplies a control voltage to the channel selector, so that the tuning, within certain limits, remains optimal. As reference for the correct tuning the frequency of the sound carrier is used. Two 5.5 MHz IF-sound signals are applied to the Phaft detector in U508. The first one originates from the IF sound section in U508, just discussed.

The second one originates from 16U506. For in the luminance detector, on account of the non-linear diode characteristic, a mix product of 5.5 MHz has been formed by the picture sound carrier mixing. This 5.5 MHz signal, just like the 5.5 MHz IF sound signal already discussed is filtered (S505), amplified and limited in U508 and, next, applied to the phase detector, via an electronic switch. The sound carrier, from which this second 5.5 MHz signal originates, has received supplementary suppression in the 33.4 MHz rejection filter, just before the luminance detector in U506.

This circuit has a high quality factor and is carefully adjusted at 33.4 MHz. If the tuning of the channel selector is correct (without automatic tuning voltage) this circuit will behave as a resistive reactance on the sound carrier producing no phase shift, because, in this case, the frequency of the sound carrier is also 33.4 MHz.

If the channel selector is wrongly tuned, the sound carrier will have a frequency higher or lower than 33.4 MHz. The 33.4 MHz circuit, in this case, functions in an inductive or capacitive manner resp. so that the sound carrier gets extra phase shift. This phase shift, after mixing in the luminance detector with the picture carrier, is retained in the mix products, so that also the 5.5 MHz signal has this extra phase shift. Consequently, if the channel selector is wrongly tuned, the two 5.5 MHz signals which are applied to the automatic tuning detector in U508, will differ in phase. The difference is converted into a proportional DC-voltage by the phase detector. Because the automatic tuning control voltage is added to the tuning voltage, it must be possible for the control voltage to be positive or negative. The output voltage of the automatic tuning detector is therefore applied to a DC-voltage amplifier receiving positive and negative supply voltages. Via the automatic tuning output 2U508 the control voltage, via R501, emitter follower TS507 and R505, is added to the tuning voltage on 2U553. As a result, the channel selector is properly tuned to the transmitter again.

Any possible sound modulation present in the automatic tuning control voltage on the output of 2U508, is suppressed by C501.

○ *VHF/UHF switching*

In the UHF range, the channel selector has a far greater tuning slope than in the VHF range.

This would mean that, with the same automatic tuning control voltage, the pull-in range of the automatic tuning in the UHF range would become too great. Therefore, the amplitude of the automatic tuning control voltage in UHF position is reduced. This is effected by supplying the voltage to U508 point 15, in UHF-position, via a larger resistor (R509) than in VHF-position (R508). As a result, the amplification of the 5.5 MHz amplifier is reduced, so that also the maximum automatic tuning voltage is reduced. In VHF-position, the maximum automatic tuning voltage is 7 V. In UHF-position, the maximum output voltage is reduced to approx. 2.3 V.

○ *Delay in switching-on the automatic Phaft tuning circuit*

In order to avoid capturing the wrong transmitter when switching on the VCR. The Phaft circuit is delayed by C502, R502, D501 and the electronic switch in U508.

Working:

When the receiver is switched on, C502 is still uncharged. This elco is charged via R502 and a resistor located in U508. This resistor is connected to earth. As long as current flows through R502, the electronic switch will be open, and the automatic tuning channel is cut-off. When elco C502 is charged, there will be no more current through R502 and the electronic switch is closed. The RC time of C502, R502 and the resistor in U508 is 5 sec. Diode D501 providing quick discharge of C502 when the +5A supply voltage drops off.

○ *In three cases, the automatic tuning voltage must be short-circuited:*

- When switching over to another channel.

In this case, the automatic tuning voltage built-up in the previous position, must be quickly discharged to ensure correct reception on the new channel.

BLOCK DIAGRAM SIGNAL "RECORDING" N1700

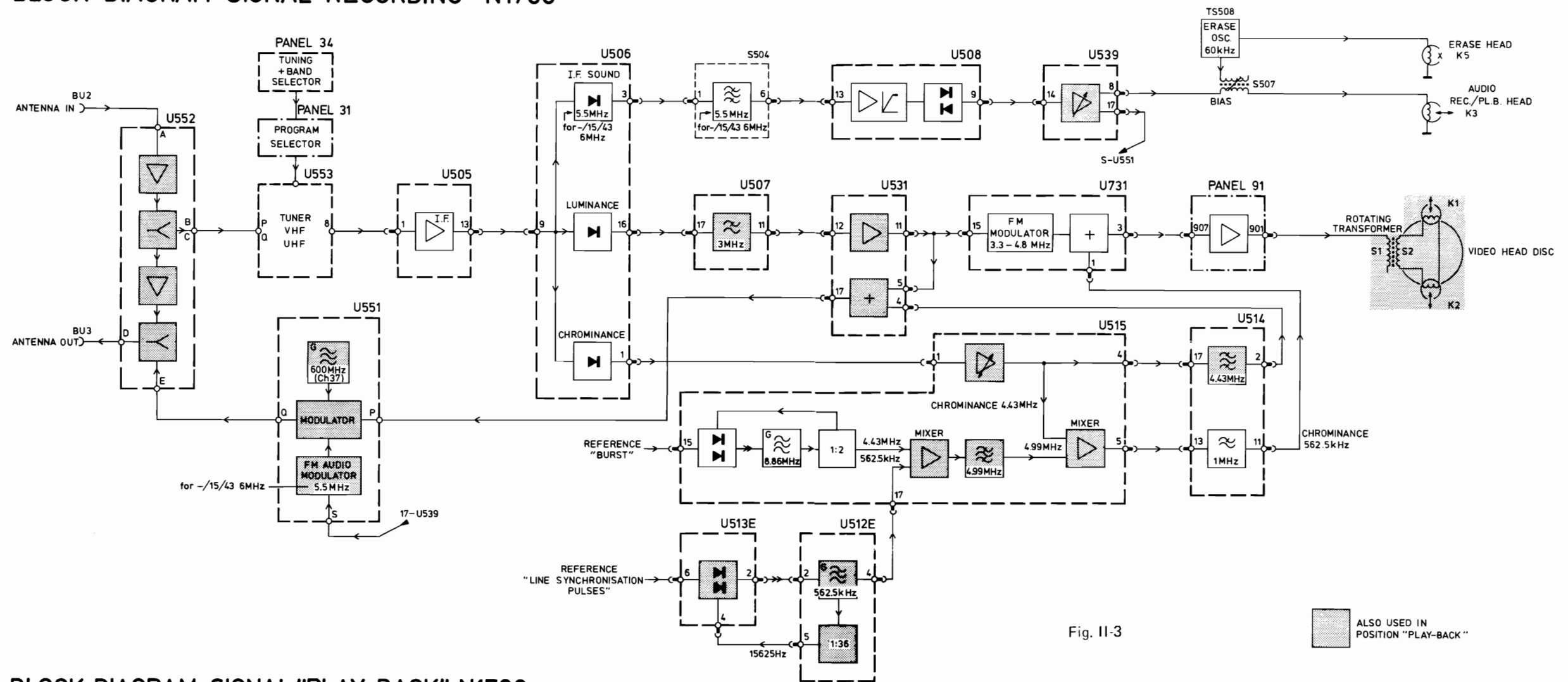

BLOCK DIAGRAM SIGNAL "PLAY-BACK" N1700

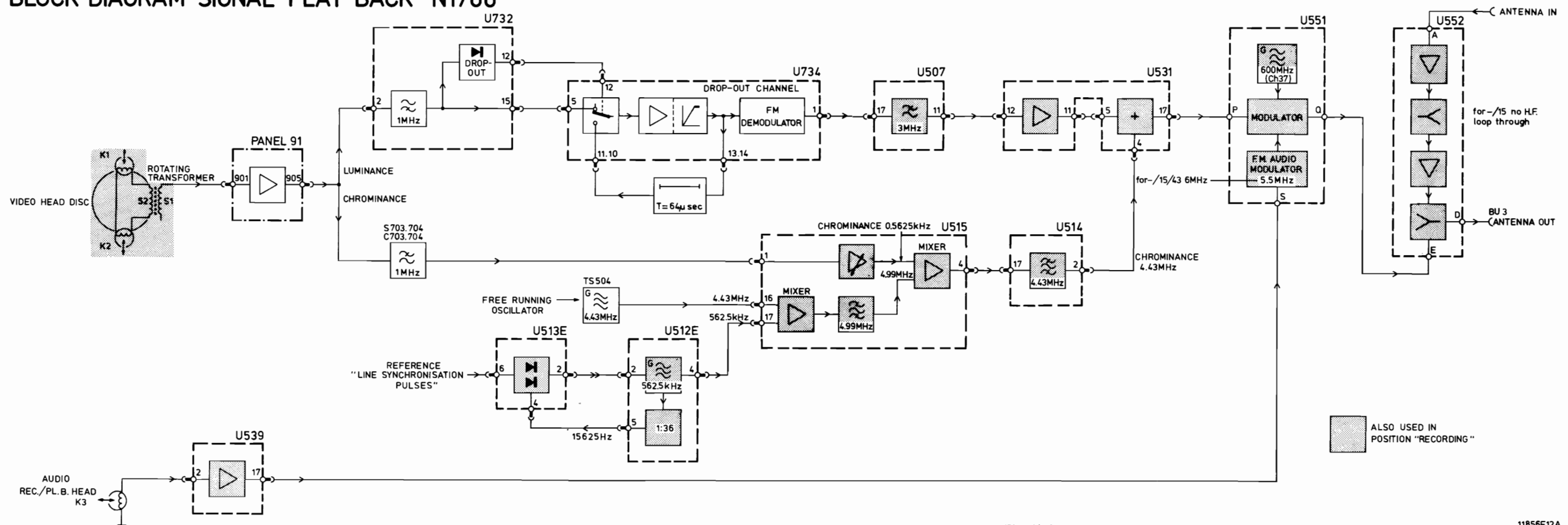

This is provided by SK319 on panel 31. SK319 is mechanically coupled with the channel selector push buttons and is closed when one of these buttons is fully pressed (pressed through).

When SK319 closes, the base of TS507 is connected to mass via SK319, so that Phaft control is put out of operation.

- Adjusting the tuning controls on panel 34 (drawer)
When the tuning controls are being adjusted, SK319 must be kept closed. In practice, during the tuning, one hand operates the tuning control, the other hand keeps the corresponding channel selector button fully depressed.

- Using a video camera not provided with an HF sound modulator.

Because the Phaft circuit needs the IF sound signal as reference, the Phaft circuit does not come into operation if only a picture carrier is supplied.

In these cases, channel selector push button no. 8 has to be used. This push button operates SK318a, which is in parallel with SK319. When push button no. 8 is pressed, SK318a changes over so that also the base of TS507 is connected to mass.

1.4.8. Signal preparation U531

In order to check to which channel the channel selector is tuned, the detected luminance and chrominance signals, on recording, are added together again and applied to the UHF modulator U551. The modulator signal, via the aerial amplifier U552, is also applied to aerial output BU3.

U531 has the following functions:

- Supplying a signal of proper amplitude polarity and DC-voltage level to the luminance recording section U731 and to the modulator U551.
- Combining the luminance and chrominance signals again in the right proportion.
- Providing the signal with new sync pulses
- Adding a VCR identification pulse to the line sync pulse (only for -/00)

The detected luminance signal on 16U506 is applied to 12U531 via a 4.43 MHz rejection filter and a low-pass filter, both contained in U507.

The necessity of these two filters will be discussed in the luminance recording section U731.

Between points 12 and 11 of U531 the luminance signal is amplified and inverted. From 11U531, the signal is applied to the FM modulator unit U731 and, via R517, TD501 and R518 to U531 again.

TD501 produces a delay of 635 ns. Resistors R517 and R518 are terminating resistors for the input and output of the delay line. The luminance signal is next supplied to a frequency correction filter in U531, with which the not ideal frequency characteristic of the delay line TD501 is compensated for. Moreover, this filter provides a certain group delay time pre-correction for the luminance signal. This group delay time pre-correction, together with the 635 ns delay of the delay line TD501 provides that the group delay time of the CVBS-signal at 17U531 is in correspondence with the transmitter standard.

Next, the luminance signal is clamped on black level in U531, the synchronisation signal is removed by a clipper and a new synchronisation signal that already has a VCR identification pulse is supplied to the video information again.

The clamping pulse, the VCR identification pulse and the new synchronisation signal have been derived from the synchronisation signal supplied to 2U531. This synchronisation signal has been separated from the luminance signal in U513E.

The chrominance signal, amplified on constant burst amplitude in U515, is supplied to 4U531 via U514. In U531, this signal is added to the luminance signal. Via 17U531 the CVBS signal is supplied to the modulator U551.

○ VCR-identification (only for -/00)

It is known that the time constant of the line synchronization circuit of the TV set must be adapted to playback a VCR signal in order to obtain a stable picture reproduction. In the present CTV chassis, like K9 and K11, this was achieved by a built-in cable. If the highest numbered channel selector push-button is pressed, the line sync circuit is adapted. Quite a number of versions already have this cable as a standard device. On the TV-set, it is indicated by VCR or VCR/VLP. Recently a development has taken place to the effect that the signal, originating from a VCR, is provided with a VCR-identification signal. This signal is detected by a VCR-identification detector in the CTV-receiver. The output signal of the detector automatically adapts the line sync circuit, independent of the channel selector push-button chosen. The VCR identification signal consists of a pulse, which is added to the line sync pulse.

In Fig. II-5 the place of this pulse in the signal is shown.

1.4.9. UHF-modulator U551

The CVBS signal and the audio signal are modulated on a RF carrier by the UHF modulator U551, and, then applied to the output socket BU3 via a signal combining circuit in U552. The carrier frequency has been adjusted by the factory at 600 MHz, which corresponds with channel 37. If so required, the carrier can be detuned ± 5 channels. The CVBS signal is applied to point P, the audio signal to point S of the unit. Before the audio signal is applied to the main modulator, it is FM modulated on a 5.5 MHz carrier within U551.

In U539, the audio signal has already undergone the pre-emphasis operation (see also 1.4.16).

○ Switching-off delay TS501, TS502

To prevent the annoying loud noise that occurs when the signal to a CTV is interrupted, for example when earlier version VCR's were switched off, it has been arranged for the modulator to remain on for 20 seconds after the VCR has been switched off.

○ Working of the switching-off delay

After switching off the set, the +1A supply voltage drops off, the +1 supply voltage remains. Now, elco C506 will only be discharged via TS502, because diode D510 is cut-off.

After approx. 20 seconds, C506 is discharged. TS502 ceases to draw base current and is cut-off. Also TS501 will then block. As a result, the supply voltage on the modulator unit points C, E and F is interrupted.

1.4.10. Luminance FM-modulator U731

Before the luminance signal is applied to the FM-modulator in U731, it must be limited to 3 MHz in bandwidth. The reason why has been explained already in the discussion about the VCR modulation diagram.

This limitation in bandwidth is effected by the low-pass filter in U507. The 4.43 MHz rejection filter removes any chrominance signal remaining on the detected luminance signal. The all-pass filter, added to the low-pass filter, compensates for the differences in delay time originating from the low-pass filter. The combined effect of the total delay time of 440 nsec is that the luminance signal modulated in FM and the transposed chrominance signal with the same delay times are added in U731. Via U531, the plug connection L55 and F45, the signal, limited in bandwidth is applied to the FM modulator in U731.

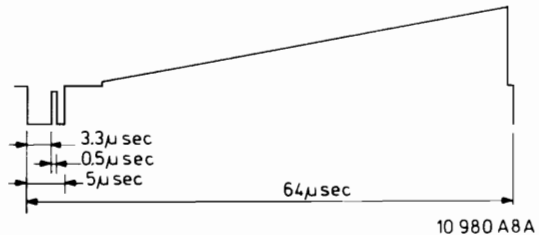

Fig. II-5

○ FM modulator

The luminance signal is converted to FM in the FM modulator, a sweep width of 1.5 MHz corresponds to peak white, and the frequency spectrum of the modulator is 3.3 to 4.8 MHz (Fig. II-6).

Before the luminance signal is FM modulated, it undergoes the usual preparations, such as:

- The signal is clamped on sync top level
- The signal is submitted to the video pre-emphasis
- The signal is submitted to a white clipper (Fig. II-6)

After the FM modulator, the signal is limited, to remove AM modulation on the FM signal.

Via a preset control used to adjust the luminance writing current, the signal is applied to the input of an amplifier. Also the downwards transposed chrominance signal is applied to this same input. Next, the added signals are applied to the writing current amplifier on p.c. board 90, via the amplifier mentioned before.

Before discussing the writing current amplifier, the chrominance recording section will be described.

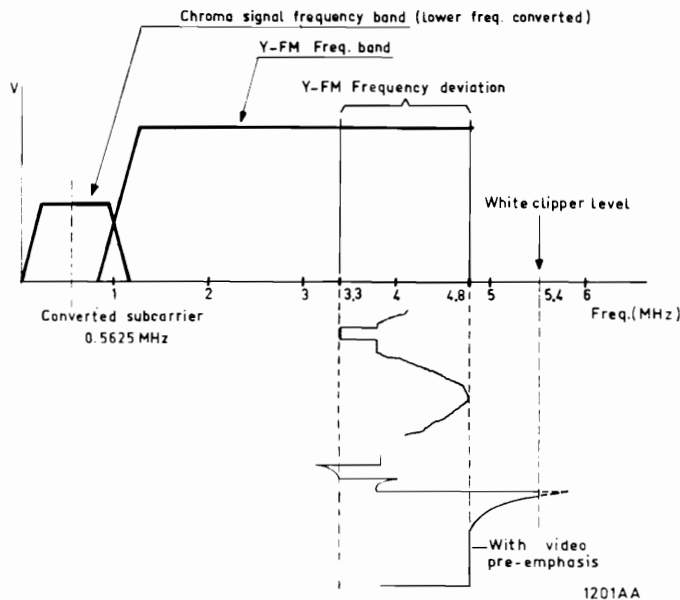

Fig. II-6

1.4.11. Chrominance, U514 and U515

○ *Transposing the chrominance signal*

The detected chrominance signal with a carrier frequency of 4.43 MHz, on recording, is transposed to a lower frequency band with a new carrier of 562,5 kHz.

The detected chrominance signal at 1U506 must first be slightly limited in bandwidth, which is effected by circuit S503, C517 adjusted at 4.43 MHz.

Via emitter follower TS503 the signal is fed to the gain controlled amplifier in U515. Here, the chrominance signal is amplified on constant burst amplitude. The controlled signal is next supplied to the recording mixer.

Also a 4.99 MHz oscillator signal generated in U515 is fed to this mixer. The output signal of this mixer, in recording position, is supplied to 13U514 via an electronic switch and a second electronic switch. In unit U514, using a low-pass filter, the desired mix product $4.99 \text{ MHz} - 4.43 \text{ MHz} = 0.5625 \text{ MHz}$ chrominance is filtered out. In U731 this signal is added to the FM modulated luminance signal, via an emitter follower, plug connection L36, F36 and potentiometer R170. The chrominance writing current is adjusted with R170.

Just like the luminance signal, the chrominance signal, on recording, is supplied to the modulator U551, via U531. For this, the 4.43 MHz chrominance signal, after the gain controlled amplifier in U515, bypasses the recording mixer and is supplied to 17U514 via an electronic switch. Next, the signal is fed to 2U514 via a 4.43 MHz band-pass filter, an amplifier and an electronic switch. 2U514 and 4U531 are connected together.

○ *4.99 MHz oscillator signal*

The 4.99 MHz oscillator signal is formed by supplying a 4.43 MHz signal and a 562.5 kHz oscillator signal to a second mixer in U515. The sum of these two signals is the 4.99 MHz signal. Using a filter, this signal is separated from the other mix products. The 4.43 MHz signal results from dividing a 8.86 MHz oscillator signal. The 8.86 MHz oscillator is

controlled by a phase discriminator to which the burst of the chrominance signal to be recorded is supplied as reference. Crystal KT502 for the 8.86 MHz oscillator in U515 is outside the unit. The reason why this unit has an 8.86 MHz oscillator is that the IC with which this oscillator is formed has been derived from an existing IC that is used in CTV-sets for producing in a simple way two 4.43 MHz signals shifted 90° in phase, from an 8.86 MHz oscillator signal. These two signals are required for the R-Y and B-Y demodulators.

○ *Chrominance AGC voltage shaper*

Because, in the PAL-system, the phase of the burst signal is shifted $+45^\circ$ and -45° , line by line, a ripple voltage is present on the control voltage applied to the 8.86 MHz oscillator from the phase discriminator in U515.

The value of this ripple voltage is directly proportional to the burst amplitude of the chrominance signal applied to 1U515. This ripple voltage is converted into a proportional DC-voltage by the colour AGC circuit and applied to the gain controlled amplifier in U515.

○ *Colour killer*

The colour killer, which is a Schmitt-trigger, is also supplied with AGC-voltage. If the AGC-voltage becomes too low, the Schmitt-trigger will change over, the electronic switch in U515 then opens and no chrominance signal is supplied to U514 any more. Also the electronic switch in U514 opens, so that no 4.43 MHz chrominance signal is supplied to 4U531 any more.

1.4.12. 562.5 kHz processor U512E

U512E supplies the following signals:

- On 4U512E, a 562.5 kHz oscillator signal
- On 5U512E, a F_H square-wave voltage (15.625 Hz)
- On 13U512E, a $2F_H$ square wave voltage ($2 \times 15.625 \text{ Hz}$)
- On 7U512E, a key pulse for the burst gate in U515
- On 16U512E, a drive voltage for the luminance indicator circuit TS506, see also chapter 1.4.17.

○ *The 562.5 kHz oscillator signal*

As mentioned already, the 562.5 kHz oscillator signal is required for producing a 4.99 MHz oscillator signal in U515. The 562.5 kHz oscillator functions as an astable multivibrator. A low-pass filter lets through only the first harmonics of the square wave because the mix in U515 can process only sine-wave signals. The 562.5 kHz oscillator is controlled by a phase discriminator in U513E, in which the line pulses of the luminance signal are compared with a signal, which is a result of the divide by 36 of the oscillator frequency.

This signal is applied to the phase discriminator via 5U512E and 4U513E.

It follows that the oscillator will oscillate at exactly thirty six times the line frequency (i.e. 562.5 kHz).

○ *Key-pulse for the burst gate in U515*

The burst gate in U515 will pass the burst signal only.

The control pulse is produced in U512E, by adding the square-wave voltages on 5U512E (with a frequency F_H)

to the square-wave voltage on 13U512E (with a frequency $2F_H$), in a certain manner. On the output 7U512E, a pulse with the required width and phase relation with respect to the burst signal, is available. This pulse is applied to the burst gate and to the colour AGC circuit, via 10U515.

Owing to variations in temperature, the phase relation between key pulse and burst signal may be changed. The burst gate in U515 will then be opened at the wrong moment. To avoid this, a drift compensator has been applied, contained in U513E.

The drift compensator is supplied with the synchronisation signal on one hand and with the $2F_H$ pulse, via 11U513E, on the other. From these two signals a correction signal is derived which is applied to the phase discriminator.

1.4.13. Reference processor U513E

U513E supplies the following signals:

- On 8U513E, the synchronization signal, separated from the luminance signal.
- On 2U513E, the control voltage for the 562.5 kHz oscillator in U512E, as mentioned previously
- On 9U513E, a 50 Hz reference pulse for the servo systems.

○ *The sync separator*

The detected luminance signal is applied to the sync separator, via 6U513E. On 8U513E, only the sync signal (inverted) is present. The sync signal is applied to the following circuits:

Outside U513E

- To the luminance indication circuit in U512E

- To 2U531

Inside U513E

- As mentioned already, to the phase discriminator for the 562.5 kHz oscillator and to the corresponding drift compensator
- To the frame sync pulse separator

○ *50 Hz reference pulse generator for the servo systems*

The servo systems in recording and playback position require a stable 50 Hz reference pulse.

Also, on recording, the frame pulse in the video signal must be modulated on the tape on a predetermined spot. To this purpose a pulse, derived from the frame pulse, is used as reference for the servo systems.

The 50 Hz reference pulse generator consists of an astable multivibrator which, on recording, is triggered by the frame pulse. The frame pulse, via an electronic switch, is applied to the generator.

The electronic switch, in recording position, is kept in lowest position by the frame pulse identification circuit. However, if in recording position for whatever reasons the frame pulses might drop off, the electronic switch automatically switches over.

The reference generator is then triggered by a signal with the mains frequency.

1.4.14. Writing current amplifier on p.c. board 91

As mentioned already, the luminance and chrominance signals to be modulated onto the tape are applied to 3U731. The amplitude of the FM signal on this point is $1 V_{pp}$. The amplitude of the chrominance signal is $110 mV_{pp}$ (for 75 % saturated colour bars).

This signal is applied to point 907 of the writing current amplifier via the plug connection F24.

The writing current amplifier TS901-TS903 supplies the writing current required for magnetizing the tape.

The luminance writing current magnetizes the tape very strongly and, so, works linearizing for the chrominance signal.

The writing current amplifier functions as a current source. The advantage being that the writing current is always constant and, so, independent of inductivity tolerances and changes of the video heads (the inductivity of the video heads decrease as they wear).

The signal is amplified by TS901. The amplification of this stage is determined by the resistors R903 and R906. By means of the transformer in the collector circuit the output transistors TS902 and TS903 are driven in anti-phase. These two output transistors are operating in class A and, by means of R909, R907, C902, R910, R908 C903 in large negative feedback.

By driving the output transistors in this manner, the severe quality demands are satisfied.

The signal is applied to the video heads K1 and K2, via the rotating transformer S1, S2 which, in the recording position, is connected to the collectors of the output transistors.

1.4.15. Audio, U539

In recording position, U539 has the following functions:

- Automatic modulation depth control
- Protection against damages to the audio track when using pre-modulated cassettes

○ *Recording amplifier with frequency pre-correction*

The audio signal supplied by the sound detector in U508 is supplied to the recording amplifier via 14U539 and a series resistor. The output of this amplifier is connected to the input via a frequency dependent network. This network provides the desired frequency pre-correction of the recording current, but also the pre-emphasis for the signal supplied to the 5.5 MHz audio FM-modulator in U551, via 17U539.

This combination is possible, because under existing relations the frequency characteristic required for recording pre-correction and of the audio pre-emphasis are practically the same.

○ *Automatic modulation depth control*

The signal at the output of the recording amplifier is also fed to a rectifier circuit. The resulting DC-voltage is applied to the base of an NPN transistor. If the signal on the output should become too great, then the rectified voltage would also increase. The transistor will become more conductive, so that the collector-emitter resistance decreases. The signal at the input of the recording amplifier and so the output voltage will decrease.

1.4.16. Erase oscillator

The erase oscillator consists of a resonance circuit formed by the inductance of the erase head K5 and the capacitors C512 and C520. The power required is supplied by TS508. TS508 is connected to this circuit via the capacitive voltage divider C513 and C514.

○ *Premagnetization current*

The premagnetization signal is taken off the erase oscillator signal and, via transformer S507, added to the audio signal. The premagnetization current is adjusted with the core of S507. Next, the signal is supplied to panel 21, via plug connection K16 and A53. On this PC-board (servo print) the switches SK201 and SK202 are fitted which are operated by the recording and start key resp.

In recording position, contacts 13 and 12 of SK201 are interconnected, so that the signal is supplied to audio head K3 via the plug connection A46. The other side of the audio head is connected to mass via a resistor in U539. The premagnetization current is measured at point 6 of check plug L1 (L16).

1.4.17. Signal indication, panel 30

LED D301 is fitted on panel 30 and lights up for 50 % if only a luminance signal is received. If both a luminance and a chrominance signal are received, this LED lights up for 100 % .

○ *Luminance indication*

As reference for the luminance indication, the synchronization signal is used.

The synchronization signal is available on 8U513E. This signal is applied to the luminance indication circuit, via 8U512E. This circuit will deliver a positive voltage only, if the synchronization signal supplied is sufficiently free from interferences.

The positive voltage is applied to the base of TS506,

via 16U512E and resistor R523. TS506 becomes conductive, so that the cathode of LED D301 is connected to earth, via R522 and this transistor. From the +4 supply voltage a current starts flowing through the diode, so that it lights up. The current through D301 is so chosen that D301 will light up for 50 % .

○ *Chrominance indication*

As reference for the chrominance indication, the chrominance AGC voltage, produced in U515 is used. As described, the AGC voltage is also applied to a Schmitt-trigger. When the chrominance signal is strong enough, output 9U515 is positive.

This positive voltage is applied to the base of TS505, via R525.

TS505 starts conducting, so that from +4, D301, R524 and TS504 now also a current can flow to mass. If both a luminance and a chrominance signal are received, the current through D301 will be maximum, so that D301 lights up for 100 % .

1.5. DESCRIPTION OF THE CIRCUIT DIAGRAM OF THE SIGNAL SECTION IN PLAYBACK POSITION

1.5.1. Introduction

In circuit diagram A, the main signal paths in the position playback are marked with a solid green line. As already mentioned in "Recording", the main signal paths on both recording and playback, are marked with a dotted violet/green line.

1.5.2. Head amplifier, p.c. board 91

In playback position, the signal induced in the video heads K1, K2 is applied to the input transformer, via the rotating transformer S1, S2. The input transformer adapts the impedance of the video head circuit to the input impedance of the first amplification stage, the field effect transistor TS904. The signal is further amplified by TS905 and TS906 and on the output point 905 has an amplitude of 70 mVeff. From this output, the signal is applied back to the gate of TS904 via feedback network C910, R922, R923, R918.

As a result, a frequency characteristic flat up to 5 MHz is obtained. The amplification of the head amplifier is abt. 700.

After the head amplifier, the signal is applied to the luminance and chrominance playback section, via plug connection F21.

1.5.3. Luminance playback section

1.5.3.1. Introduction

The specific luminance playback section is made up of the units U732 and U734. Its function is to separate the chrominance signal from the luminance signal modulated in FM and, next, to demodulate it. Moreover, it must fill up drop-outs free from interference.

1.5.3.2. FM playback processor U732

U732 has the following main functions:

- Suppressing the chrominance signal
- FM gain controlled amplifier
- Drop-out detector

○ Suppressing the chrominance signal

Before the head signal is supplied to U732, it is affected by the suction filters C710, S705 and C711, S706, which are adjusted at 562 kHz and 590 kHz resp.

Consequently, the chrominance signals in the neighbourhood of the 562.5 kHz chrominance carrier are crushed, so that they cannot cause interference in the luminance channel. Next, in U732, the signal is fed to a high-pass filter via an emitter follower.

With R711 the high-pass filter is adjusted. The frequency characteristic in minimum and maximum position of R711 is shown in Fig. II-7. Adjusting R711 involves compromising.

On one hand, it is important that the FM sidebands in the range between 1 and 2 MHz are not suppressed too much, because the FM sidebands in this range are important for the resolution of the detected luminance signal. On the other hand, the amplitude of these FM sidebands may not become greater than that of the FM carrier proper.

This is evident, when the playback frequency characteristic of the video heads is considered, Fig. II-8.

The conclusion is that, proportionally, the FM carrier is reproduced with a much smaller amplitude than the

FM side-bands in the range between 1 and 2 MHz.

If the amplitude of the side-bands exceeds that of the carrier, the limiter in U734 gets stuck, so that information is lost. This symptom is recognizable in the picture in the shape of short, black horizontal stripes after a black-and-white changeover. Moreover, the high-pass filter suppresses the chrominance signal.

○ FM gain controlled amplifier

In the subsequent gain controlled amplifier the FM signal is amplified in a manner that there is always an FM signal of constant amplitude available on the output of 15U732. The control voltage for the gain controlled amplifier is produced by rectification of the FM signal. After the gain controlled amplifier, all signals with frequencies exceeding the playback frequency range of the video heads (approx. 5 MHz) are suppressed by the low-pass filter.

○ Drop-out detector

The function of the drop-out detector is to recognize a drop-out in the FM signal and derive a switching pulse. In its turn, this switching pulse actuates the drop-out compensator, so that the drop-out in the output signal is filled up. The drop-out detector is an envelope detector. The output signal of the detector triggers a Schmitt-trigger controlling an electronic switch in U734. The sensitivity of the detector is factory adjusted.

1.5.3.3. FM-demodulator, U734

The FM-signal at 15U732, controlled in amplitude, is next supplied to U734. In U734, the FM-signal is amplified, limited and demodulated. Via a low-pass filter (3 MHz) by which the FM-carrier remainders, still present, are suppressed and an amplifier, in which also

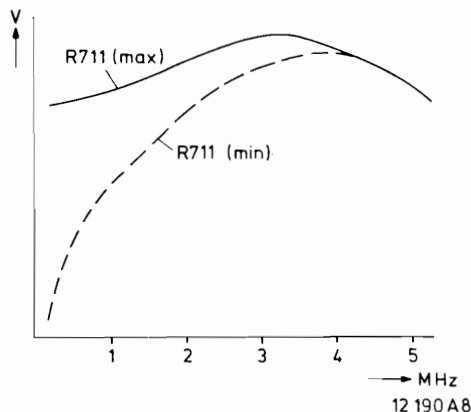

Fig. II-7

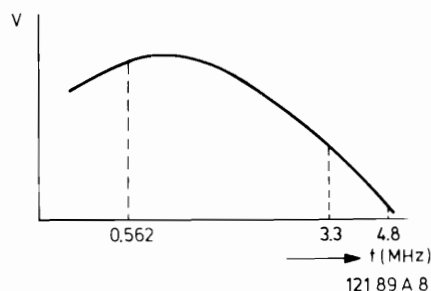

Fig. II-8

video de-emphasis is effected, the video signal is fed to 1U734.

1U734 is connected to 17U507 via plug connection F42, L52. From this point on, the luminance signal follows the same signal path to the aerial output as in recording position.

○ *Drop-out compensation*

If a drop-out occurs in the FM-signal reproduced, it will be detected by the drop-out detector in U732.

The Schmitt-trigger delivers a signal, so that the electronic switch in U734 switches over. The output of the limiter is now interconnected with the input via the 64 μ s delay line.

At the moment of switch-over, a 64 μ s delayed FM-signal will be present at 11U734. A line duration is also equal to 64 μ s, from which it follows that the drop-out is filled up by the information of the preceding line.

Because in practice the information of 2 subsequent lines is practically the same, the drop-out is filled up invisibly.

In case of a long drop-out (longer than 1 line duration), the line last reproduced correctly will be repeated again and again. As a result of reflections in the 64 μ s delay-line, the signal quality slightly decreases on every repetition.

1.5.4. Chrominance playback section

1.5.4.1. Introduction

The specific chrominance playback section is made up of low-pass filter S703, S704, C703-C707 and the transistors TS702 and TS703. The rest of the chrominance playback circuits are contained in the units U512E, U513E, U514 and U515 and, in playback position, most of them work in the same way as in recording position. The deviations only are discussed in this chapter.

1.5.4.2. Low-pass filter S703, S704, C703-C707

The video head signal is applied to the chrominance playback section, via the plug connection F21 and C702. With low-pass filter S704, C704-C707, the 562.5 chrominance signal is adequately separated from the remaining head signal.

Next, the signal is applied to the gain controlled amplifier in U515, via amplifier TS702, emitter-follower TS703, plug connections F33 and L33.

1.5.4.3. Chrominance AGC + playback mixer U514, U515

The gain controlled amplifier in U515 amplifies the 562,5 kHz chrominance signal of constant burst amplitude, which is then applied to the mixer.

After mixing with the 4.99 MHz oscillator signal, also present on playback, the difference in mix product 4.99 MHz - 562.5 kHz is our original 4.43 MHz chrominance signal again.

This mix product is separated from the other mix products by the 4.43 MHz band-pass filter in U514. The 4.43 MHz is next amplified and supplied to 2U514 via the electronic switch. The electronic switch is activated by the colour killer and is opened when the chrominance signal present is too weak.

From 2U514 on, the chrominance signal follows the same signal path as in recording position. It means that in U531 the chrominance signal is added to the luminance signal again and supplied to the UHF-modulator U551.

1.5.4.4. 4.99 MHz processor + chroma AGC voltage former U515, U514

As mentioned above, a 4.99 MHz oscillator signal must be available on playback. This signal is obtained by applying a 4.43 MHz and a 562.5 kHz oscillator signal to a second mixer in U515. The sum mix product is the 4.99 MHz signal. Because the 4.43 MHz oscillator signal, which is applied to this mixer, may be seen as the new chrominance carrier, this oscillator signal must have great stability. In playback position, the 4.43 MHz oscillator signal, used on recording, does not have this stability and therefore cannot be used.

This is explained as follows:

The 8.86 MHz oscillator signal, used on recording, is also required in playback position for obtaining the AGC voltage for the gain controlled amplifier in U515. This is because the phase-discriminator, the colour AGC and the 8.86 MHz oscillator are contained in one IC. Suppose that the frequency of the 4.43 MHz signal that appears after division, in playback position tends to increase.

After mixing with the 562.5 kHz oscillator signal, the 4.99 MHz signal will become higher, likewise the carrier of the 4.43 MHz chrominance signal on 1U514 obtained after mixing. The burst of this signal is applied as reference to the phase discriminator in U515. The phase discriminator will deliver a control voltage to the 8.86 MHz oscillator, so that the frequency deviation becomes greater still. It follows that on playback an extra 4.43 MHz oscillator is required. This oscillator is made up of TS504 and crystal KT501. This oscillator signal is applied to the mixer in U515 via 16U515.

1.5.4.5. Additional AGC for the chrominance gain controlled amplifier in U515

Note: In the VCR-long play system, the video tracks are written on the tape against each other. To have adequate track separation, the air gaps of the two video heads are at an angle of 30° with respect to each other. As a result, the relevant video head becomes insensitive to the adjacent track on playback. However, this is only true for high frequencies, far less so for low frequencies, as the 562.5 kHz chrominance signal.

In playback position, it is inevitable that in the video head a signal of the adjacent track is induced. This causes amplitude and phase interferences in the burst signal. Amplitude faults are corrected by the colour AGC-circuit in U515. Also phase disturbances occurring in an AF-rhythm (0-16 Hz) can be processed by the phase discriminator and colour agc-circuit. Phase disturbances occurring at higher frequencies (16...300 Hz), however, cannot be processed by the phase discriminator any more. The colour AGC-circuit then applies a wrong control voltage to the chrominance gain controlled amplifier. Therefore, the interference signals with high frequencies must be compensated for by another AGC-control, contained in U514.

Operation: The 4.43 MHz chrominance signal at 1U514 is supplied to an envelope rectifier. Via the electronic switch, which is controlled by the burst-key pulse, only the rectified burst information is passed on to the AGC adder circuit in U515.

1.5.4.6. 562.5 kHz processor U512E

In playback position, U512E works in the same way as on recording. The luminance indicator drive circuit, however, is switched off.

1.5.4.7. Reference processor U513E 50 Hz reference generator

Because on playback, there is no supply voltage on 13U513E, the frame pulse identification circuit will not work. Consequently, the electronic switch is set to top position. As a result, the 50 Hz reference generator in playback position, is continuously triggered by a signal having the mains frequency.

1.5.5. Sound

On playback, the signal induced in the audio head is applied to the preamplifier in U539, via contacts 11 and 12 of SK201, the plug connections A56 and K11. In this amplifier stage, also playback frequency correction is effected. Via an electronic switch, the signal is supplied to the amplifier, which is also used on recording. After the playback key is depressed, this electronic switch is closed at some delay. As a result, the audio signal is passed on only if the tape servo system is pulled-in.

In position playback, the audio detector in U508 may not supply any interference signals (noise) to U539. This is effected by opening the electronic switch located between the limiter and audio detector in U508. The switch is opened by applying no voltage to 17U508.

2. THE SERVO SECTION (circuit diagram B)

General

The circuitry of the servo section is mainly located on p.c. board 21.

In the following description the units are shown as block diagrams.

2.1. THE HEAD SERVO

The head servo ensures that the head disc rotates at the correct speed and that the video heads are in a specific position relative to the tape during the frame pulses. For this purpose a reference signal of constant frequency is required.

The signal which is applied to point A51 has a frequency of 50 Hz and, during recording, it is derived from the frame pulses of the signal to be recorded and during playback from a signal of the mains frequency.

As the head servo requires reference pulses with a frequency of 25 Hz, the 50 Hz reference signal is applied to a 1:2 divider which is a bistable multivibrator (flip-flop) inside U236.

The slope generator also inside U236 (which operates in accordance with the bootstrap principle) converts the square-wave 25 Hz signal available at B43 into a slope signal.

The permanent magnet which is mounted underneath the head disc induces a pulse in servo head K6 upon every revolution of the head disc.

If the speed of the head disc is correct this pulse will be applied to point 17 of U236 with a repetition frequency of 25 Hz. This pulse triggers a monostable multivibrator (the inverter between points 7 and 11 of U228 is part of this multivibrator). The output pulse of this multivibrator is applied to the sample gate, which ensures that the instantaneous value of the saw-tooth voltage is applied to the storage circuit in U219 during the defined time of the one-shot pulse only.

The output pulses of this multivibrator at point 15 of U236 are applied to the protection circuit against blocking of the head disc on panel 11, via A61.

The reference pulse whose amplitude corresponds to the instantaneous value of the slope voltage at B41 is applied to the input of the storage circuit in U219. In this circuit a capacitor is charged to a voltage which corresponds to the peak value of the reference pulse.

The d.c. voltage across this capacitor, which is a measure of the point where the slope voltage is sampled by the servo pulse, is applied to the - input of the operational amplifier. The + input of the operational amplifier receives a d.c. voltage which is adjustable with a potentiometer.

If the two input voltages of the operational amplifier are equal, the phase of the head drum will be correct.

In order to stabilize this operational amplifier and to ensure that it has a specific frequency response, feedback is provided in the form of both a positive and a negative feedback circuit. Both circuits are frequency dependent. This ensures that small deviations from the nominal phase of the head disc result in a substantial variation of the output voltage of the operational amplifier.

By means of the potentiometer at the + input of the operational amplifier the balance is adjusted, i.e. the voltage

across the capacitor in the storage circuit for which the operational amplifier is balanced.

Since this voltage is defined by the point where the slope voltage is sampled by the servo pulse and since the magnet underneath the head disc has a fixed position relative to the video heads, this potentiometer in fact adjusts the location of the picture gap.

The output voltage of the operational amplifier is applied to the output stage. This output stage comprises TS201 and the transistor in U219.

TS201 supplies the current for the head disc motor M1. As this motor is included in the emitter circuit of TS201 the voltage across the motor is proportional to the output voltage of the operational amplifier.

When the recorder is switched off, the back emf produced by the motor (M1) running on, is used to turn on the transistor in U219, so that a short circuit is applied across the motor braking it rapidly, thereby ensuring that the negative $V_{be\ max.}$ of TS201 is not exceeded.

The interference suppression circuit on p.c. board 40 serves for suppressing interference voltages induced by the motors.

2.2. THE DIGITAL LOCK-IN CIRCUIT (U228)

The digital lock-in circuit ensures that after the VCR has been switched on the head servo will lock-in as soon as possible.

For this purpose the 25 Hz reference signal from U236 is compared with the frequency of the pulses from the head servo.

In the locked-in condition the reference pulse which is produced by the monostable in U228 is always followed by the sampling pulse which is applied to point 17 of U228. Flip-flop 1 (see Fig. II-9) is then always set by the reference pulse and reset by the sampling pulse, whilst flip-flop 2 is set by the sampling pulse and reset by the inverted reference pulse, so that a squarewave signal with a frequency of 25 Hz will appear at the outputs of these flip-flops. As the inverted reference pulses and the signal at the Q-output of flip-flop 1 are applied to the nor-gate, the output signal of this gate will always be "0".

The sampling pulses and the signal at the \bar{Q} -output of flip-flop 2 are applied to the and-gate, so that the output signal of this gate will always be "1".

As a result, the output of the lock-in circuit (point 3 of U228) will not change.

If the speed of the head disc is for example too low, the reference pulses will not always be followed by a sampling pulse, but at certain instants 2 reference pulses will appear between 2 sampling pulses (see Fig. II-10). Flip-flop 1 then cannot be reset by the sampling pulse because it is already in the "0" state, so that the voltage waveform appears at the Q-output (see Fig. II-10).

This voltage and the inverted reference pulse are applied to the nor-gate, so that a pulse appears at the output of this gate (point A) each time that 2 reference pulses appear between 2 sampling pulses (viewed in time). The negative-going edge of this pulse which is applied to the base of TS1 via a capacitor turns on transistor TS1, so that capacitor C in U219 is charged to a higher voltage. This voltage is applied to the operational amplifier, so that the speed of the head disc motor increases.

When the speed of the head disc is too high, 2 sampling pulses will appear between 2 reference pulses at certain instants.

Flip-flop 2 then cannot be reset by the reference pulse, because this flip-flop is then already in the "0" state, so that a voltage waveform as outlined in Fig. II-11 appears at the \bar{Q} -output.

This voltage waveform and the sampling pulse are applied to a nand-gate, so that a pulse appears at the output of this gate (point B) whenever 2 sampling pulses appear between reference pulses. The positive-going edge of this output pulse, which is applied to the base of TS2 via a capacitor will turn on this transistor TS2, so that capacitor C is discharged. The discharge voltage is applied to the operational amplifier so that the speed of the head drum motor is reduced.

2.3. THE TAPE SERVO

The tape servo ensures that tape transport is as constant as possible both on recording and playback and that, on playback, the magnetic tracks registered on recording, have a fixed position with respect to the video heads, thus allowing for maximum scanning of the tracks.

The servo pulses, induced by the 5 permanent magnets underneath the flywheel in servo head K7, are applied to Schmitt-trigger TS109 and TS110 (on panel 11). The squarewave signal present at point A32, on recording, is supplied to the input of the monostable multivibrator in U236, via contacts 8 and 9 of SK201 and 8 and 9 of SK202. The output pulse of this multivibrator passes on the instantaneous value of the sawtooth voltage to the tape servo unit U230.

The sawtooth voltage is derived from the squarewave 25 Hz signal present at point 10 of U236.

This 25 Hz reference signal is supplied to point 16 of U237. After the amplifier stage in this unit, this signal is supplied to an electronic switch which is operated by the +3 supply voltage.

Because this +3 supply voltage is available only during recording, the reference signal is now fed to the sawtooth generator, via a monostable multivibrator, point 9 of U237 and point 9 of U236. On recording, also the sync signal is modulated on to the tape. To this purpose, after differentiation, the reference signal is fed to sync head K4, via point 17 of U237, contacts 18 and 19 of SK201 and A42. R201 operates here as measuring resistor.

To ensure that on playback maximum scanning of the video tracks by the video heads is obtained, the position of the video heads with respect to the video tracks is adjusted by means of tracking control. To this purpose, the 25 Hz reference signal is fed to the sawtooth generator via tracking control. This tracking control is made up of two monostable multivibrators, connected in series, of which the pulse width is adjustable from 10 to 30 ms, using R95 (tracking control). So, the total control range of R95 is from 20 to 60 ms.

This delayed reference signal is now supplied to point 9 of U237 via the electronic switch and a monostable multivibrator, the latter has a pulse width of 20 ms and ensures that the reference signal is symmetrical.

On playback, the sync pulses read from the tape by K4, are applied to amplifier stage TS203, via contacts 17 and 18 of SK201. With the output signal of this amplifier, after it has been amplified in U237 once again,

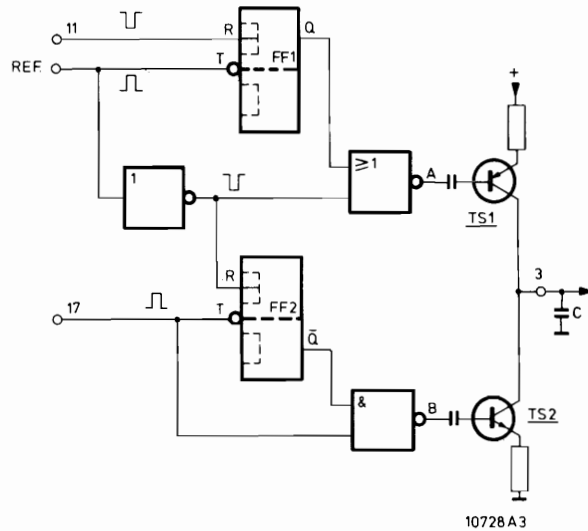

Fig. II-9

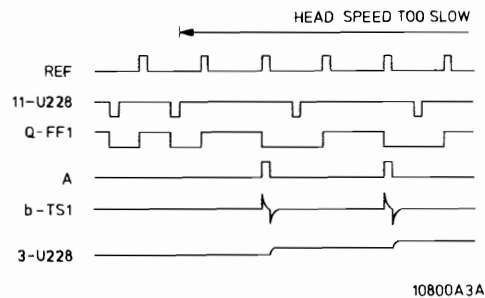

Fig. II-10

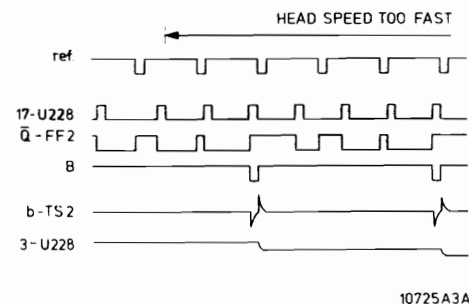

Fig. II-11

the monostable multivibrator is triggered. The output pulses of this multivibrator, which are 4 ms wide, are applied to U236 via contacts 7 and 8 of SK201 and 8 and 9 of SK202.

The servo pulses, present at A32 both on recording and playback, are applied to the speed discriminator in U230, via point 13 of U230 (see Fig. II-12). It is made up of two monostable multivibrators connected in series. The first one supplies the scanning pulse, the second one the reset pulse of a sawtooth generator operating according to the bootstrap principle. The capacitor after the switch is charged up to the instantaneous value of the sawtooth voltage (see Fig. II-13). At nominal tape speed, this voltage will be approx. 6 V.

If, for instance, the tape speed becomes too high, then the servo pulses will arrive at the input at a higher frequency, so that the capacitor is charged up to a higher voltage (see Fig. II-13). Because this voltage is applied to the minus input of an operational amplifier, the result will be that the tape transport motor is braked.

If the tape speed becomes too low, the capacitor will be discharged, so that the speed of the tape transport motor increases. The buffer stage after the capacitor ensures that the capacitor is not loaded.

During fastwinding, a positive voltage is applied to B1. As a result, TS204 is turned on and also TS205 will be driven into saturation. Consequently, a positive voltage of approx. 26 V is applied to the input of the output stage, so that the speed of the tape transport motor increases.

The friction motor M4 ensures that the tape remains taut. D201 is turned off then, so that servo control is switched off.

The other circuits of the tape servo are identical to those of the head servo. For the circuit descriptions is referred to the description of the head servo.

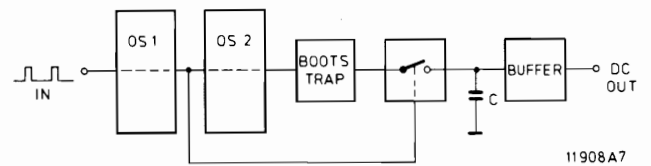

Fig. II-12

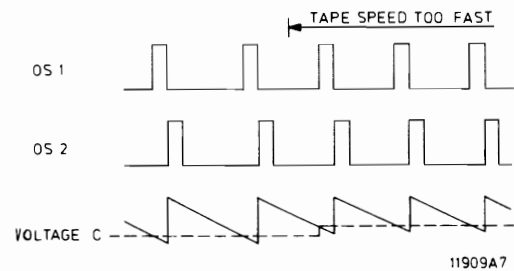

Fig. II-13

3. SUPPLY AND PROTECTION SECTIONS (circuit diagram C)

3.1. SUPPLY SECTION

The VCR is adaptable to the usual mains voltages by resoldering the connections between the primary windings of the mains transformer, see chapter III point 1.4.1. The mains transformer is protected by the thermal fuse VL1.

From the AC-voltages across the 4 isolated secondary windings of the transformer, the supply voltages for the set are derived on panel 11.

3.1.1. +1 (12 V) supply voltage

The AC-voltage between measuring points 103 and 104 are rectified by D102 and smoothed by C104. This DC-voltage is applied to the collector of TS1 via measuring point 111. The base of this transistor is connected to the emitter of driver transistor TS113 via measuring point 110. To give this transistor a large control range, the collector is connected to a high DC-voltage (+10) via R160. The drive of this transistor is provided by stabilizer IC101. Amongst others, this IC contains a voltage source with very constant output voltage and a differential amplifier. The + input of the differential amplifier is connected to the output of the voltage source via points 5 and 6, that has an output voltage of 7 Volts.

A voltage of 7 V is also applied to the minus input of the differential amplifier, derived from voltage divider R105, R106 and R107, R108.

Assuming that the +1 supply voltage increases, the voltage at the minus input of the differential amplifier also increases, so that the output voltage of this amplifier decreases. As a result, also the output voltage of the stabilizer on point 10 will decrease, so that the base voltage of TS113 increases and the conduction of this transistor will decrease.

The resulting voltage decrease on the base of TS1 will decrease the conduction of this transistor, so that the assumed voltage increase is compensated for.

IC101 also contains a current limiter transistor.

The base of this transistor is connected to the junction of the voltage divider R113, R109 via point 2 of IC101, whilst the emitter is connected to the +1 supply voltage via point 3 of IC101. If the current of the +1 supply voltage decreases, the voltage across R101 will increase. As a result, the base-emitter voltage of the current limiter transistor will also increase.

R101 is so dimensioned that, at a current of approx. 2.5A, the base-emitter voltage of the current limiter transistor is 0.7 V, so that this transistor is turned on. As a result, the base current of TS113 will decrease, so that the emitter voltage and so the base voltage of TS1 will decrease.

The +1 supply voltage will consequently decrease and also the current. Also at higher loads the current through R101 will never exceed 2.5A.

The +1 supply voltage is adjusted by determining the right value from a series for the resistors R107 and R108, see chapter III pt. 1.4.2.

Because the aerial amplifier and the electronic clock should also operate when the set is switched-off, the +1 supply voltage is available as soon as the VCR is connected to the mains.

○ The +1A supply voltage

The +1A supply voltage is the +1 supply voltage switched via the contacts 5 and 9 of RE102. RE102 is activated when the set is switched-on.

○ The +1B supply voltage

The +1B supply voltage is the +1 supply voltage which after switch-on of the set is switched-off, via contacts 1 and 9 of RE102.

3.1.2. The +10 (33 V) supply voltage

The AC-voltage between measuring points 101 and 102 is rectified by D101 and smoothed by C103. The +10 supply voltage thus obtained is switched-on via contacts 8 and 12 of RE102.

3.1.3. The +11 (40 V) supply voltage

The AC-voltage between measuring points 105 and 106 is rectified by D103 and smoothed by C107. The +11 supply voltage thus obtained is used to energize the unlocking magnet S6.

3.1.4. The +7 (27 V) supply voltage

After switch-on of the set, the +11 supply voltage is applied to the collector of TS101 via contacts 7 and 11 of RE102. Via voltage divider R111, R102 a voltage proportional to the +7 supply voltage is applied to the base of TS103. The emitter of this transistor is connected to the stable +1A supply voltage, via D105.

If, for instance, by a change of load, the +7 supply voltage tends to decrease, the voltage on the base of TS103 will also decrease and therefore also the collector current. As a result, the base voltage of TS101 will increase, so that the assumed voltage decrease of the +7 supply voltage is compensated for.

If, by an increase of load, the current through R114 has increased to approx. 130 mA, the base-emitter voltage of TS102 will have increased to 0.7 V, so that this transistor is turned on. Consequently, the base current of TS101 will decrease, so that also the emitter voltage will decrease. As a result, the maximum load of the +7 supply voltage is limited to 130 mA.

3.1.5. The +8 (32 V) supply voltage

After switch-on of the set, the AC-voltage between measuring points 107 and 108 is applied to the anode of D108, via contacts 6 and 10 of RE102. Here, this AC-voltage is monophasic rectified and smoothed by C112. The current source formed by TS104 is used to protect TAA550, that produces the tuning voltage, from overload.

Load variations of the +8 supply voltage cause current changes through R117, so that the voltage across this resistor also changes. If, for instance, the collector current of TS104 tends to increase, the voltage across R117 will also increase. Because the voltage across D107 is constant, the voltage on the base of TS104 will also increase. As a result, the conduction of TS104 will decrease, so that the assumed increase of the collector current of TS104 is compensated for.

3.1.6. The -9 (-33 V) supply voltage

After switch-on of the set, the negative phases of the AC-voltage present between measuring points 107 and 108, are rectified by D109 and smoothed by C111. The -9

supply voltage thus obtained is used for Phaft on panel 51. Here, R120 operates as limiter resistor for the zener diode on panel 51.

The AC-voltage applied to connecting point R1 via R119 and C113, is used as reference signal for the reference oscillator U513 on panel 51.

The AC-voltage which is also present at P74 if the set is switched-on, is used as 50 Hz reference signal for the electronic clock.

3.2. CONTROL AND PROTECTION SECTION

General

The ON/OFF flip-flop IC102 consists of 2 multivibrators, the first of which is switched as set/reset flip-flop and used as a debounce circuit for SK8. The second flip-flop is switched as trigger flip-flop and switches over on every positive slope on the T-input. When the set is connected to the mains, the +1 supply voltage is built-up. C126 then is still uncharged, so a part of this voltage is applied to the reset input of the T flip-flop, via the voltage divider R141, R142.

As a result, the Q-output of this flip-flop (point 15 of IC102) is kept at "0".

3.2.1. Switch-on

The VCR can be switched-on only, if the cassette holder is closed. SK11 is then closed. The set is switched-on by depressing the on/off push button (SK8) or by the electronic clock, if all switch-on demands have been satisfied (see the description of the electronic clock). When the on/off push button is depressed, a positive voltage is applied to the set-input of the set/reset flip-flop, via P64. The Q-output (point 1 of IC102-2A) then becomes "1", so that the trigger flip-flop changes over. As a result, the Q-output of this flip-flop (point 15 of IC102-2B) also becomes "1". This positive voltage is applied to the base of TS105, via R140, so that this transistor is turned on and RE101 is energized.

Point 1 of the threading motor M3 is now connected to the +1 supply voltage via P54, contacts 8 and 9 of RE101, P53, contacts 1 and 2 of SK13, 1 and 2 of SK11 and P51, whilst point 2 of the threading motor is connected to mass, via P56 and contacts 5 and 6 of RE101.

As a result, threading-in starts.

At the same time, via D113, relay RE102 is connected to the +1 supply voltage, so that this relay is energized and all other supply voltages are switched-on.

After bracket 271 (see exploded view) has turned a few degrees, SK12 changes over and, when the lower drum is fully threaded-in, SK13 changes over. Now, point 1 of the threading motor is connected to mass, via P54, contacts 8 and 9 of RE101, P53 and contacts 1 and 4 of SK13, so that the threading motor is short-circuited and is rapidly braked.

Now, RE102 is connected to the +1 supply voltage, via D112, so that the VCR remains switched-on.

If the VCR is switched-on by the electronic clock, this clock provides a positive voltage to P75, which is applied to the base of TS105, via R140. As a result, the set is switched-on.

Diodes D110 and D111, connected in parallel with relays RE101 and RE102, are used for short-circuiting the high induction voltages in the coils of these relays when they are released.

3.2.2. Switch-off

The VCR is switched-off by depressing the on/off push-button or by the electronic clock.

By depressing SK8, the Q-output of the set/reset flip-flop becomes high, so that the trigger flip-flop changes over. Because the set is switched-on already (the Q-output of IC102-2B is "1"), the Q-output of the trigger flip-flop will become "0". The base voltage of TS105 then also becomes 0 V, so that this transistor starts blocking and RE101 is released.

Now, point 2 of the threading motor is connected to the +1 supply voltage, via P56, contacts 5 and 4 of RE101, P55, contacts 2 and 1 of SK14, 1 and 4 of SK12, 1 and 2 of SK11 and P51, whilst point 1 of the threading motor is connected to mass, via P54 and contacts 8 and 7 of RE101.

As a result, threading-out starts.

After bracket 271 has turned a few degrees, SK13 changes over and, when the lower drum is fully threaded-out, SK12 changes over. Because the diodes D112 and D113 are not connected to the +1 supply voltage any more, RE102 is released so that all other supply voltages are switched-off. Point 2 of the threading motor is now connected to mass, via P56, contacts 5 and 4 of RE101, P55, contacts 2 and 1 of SK14 and 1 and 2 of SK12, so that the threading motor is short-circuited and is rapidly braked.

When RE101 is released, threading-out starts, whilst RE102 remains energized until the lower drum is fully threaded-out. Only then SK12 changes over and the anode of D112 becomes voltageless so that RE102 is released. During threading-out, the +1A supply voltage is applied to the monostable multivibrator for releasing the push-buttons, via contacts 1 and 2 of RE101, R122 and R137. So at the moment RE101 is released, this multivibrator is triggered, so that all recording and tape transport buttons depressed, are unlocked.

SK14 is fitted, to prevent the tape from being damaged if, during threading-in or threading-out, one of the fast-winding keys is depressed.

This switch is mechanically coupled with the fastwinding keys and interrupts the threading-in or threading-out procedure, if one of the push buttons is depressed.

SK15 is coupled with the eject-key and connects point R2 to mass if the eject key is depressed. The base of TS105 is now connected to mass via R140, so that this transistor starts blocking and the set is switched-off.

If the set has been switched-on by the electronic clock, the voltage at P75 will become 0 V after the turn-on time has expired. As a result, TS105 also blocks and the set is switched-off.

If the set has been switched-on by the electronic clock and the stop push button is depressed, the contact between point 12 and 13 of SK202 is broken, so that P73 becomes voltageless. The electronic clock now changes over to the time-of-day, so that P75 also becomes 0 V and the set is switched-off.

If the set has been switched on by the electronic clock and the ON/OFF push button is depressed, then the Q-output of the trigger flip-flop becomes "0". Via R147, P34, A11, contacts 13 and 12 of SK202, A13, P31 and P73, this "0" is applied to the clock, so that the clock changes over to the time-of-day. However, the set remains switched-on, because the Q-output of the trigger flip-flop has become "1". By depressing the ON/OFF push-button once again, the VCR is switched-off.

3.2.3. Blocking tape-transport at stop

To ensure that no tape transport whatsoever takes place if none of the tape transport push buttons is depressed, the lower reel disc is blocked, using S1.

During threading-in, the gate of TS112 is connected to the +1 supply voltage, via D115, so that this FET is turned on. Via D129, the +1 supply voltage is applied to the emitter of TS106 and, via R159, to the cathode of D130, so that across this diode a voltage of 9.1 V appears. This voltage is applied to the base of TS106, via the conducting TS112 and R126, so that this transistor is turned on, S1 is energized and the lower reel disc is blocked.

If the set is threaded-in, the +4 supply voltage is available, which is applied to the emitter of TS106 via contacts 1 and 2 of SK9, P23 and D118. Via D104, junction R156, R157 is now connected to the +1 supply voltage, so that C134 cannot be discharged.

As a result, TS112 remains conductive and S1 remains energized. When the start key is depressed, the +4 supply voltage is switched-off, so that the emitter of TS106 becomes voltageless and the blocking of the lower reel disc is released.

In fastwind position, SK9 is changed over. The emitter of TS106 is now voltageless, whilst the gate of TS112 is connected to the +4 supply voltage, via D117, P32 and contacts 1 and 4 of SK9. As a result, TS112 remains conductive and C134 retains its load. If now the stop key is depressed, the +4 supply voltage is applied to the emitter of TS106, via contacts 1 and 2 of SK9, P23 and D118, so that this transistor is turned on and the lower reel disc is blocked immediately.

In rewind position, the connection between points 1 and 2 of SK14 is interrupted, so that junction R156, R157, via D104 is not connected to the +1 supply voltage any more. Via R158, D124 and R156, C134 is now discharged rather quickly, so that TS112 starts blocking and the lower reel disc blocking is released.

If the stop key is now depressed, SK14 changes over. Junction R156, R157 via D104 is connected to the +1 supply voltage again and, because D124 is blocked, C134 is charged only slowly via the high-ohmic R157.

After approx. 3 seconds the voltage at the gate of TS112 has increased to an extent that this FET is turned on. Now, also TS106 is turned on, so that the lower reel disc is blocked at a delay. This delay is necessary, because, if after rewind the lower reel disc would be blocked immediately, tape loops might easily occur.

During threading-out, D104 ensures that negative interference pulses induced by the threading motor do not discharge C134 or destroy TS112.

D120 is used to protect TS106 from the high induction voltages in S1 when S1 is released.

3.2.4. Automatic release of recording and tape transport keys

Using S6, the recording and tape transport keys may be electronically released. This magnet is energized by a pulse supplied by a monostable multivibrator, made up of Darlington circuit TS107, TS108 and NOR IC103-4D. This monostable multivibrator ensures that, if only a pulse shaped drive signal is available, sufficient current is driven through S6 for approx. 1.5 sec. These 1.5 sec are mainly determined by C118, R125 and R135. Because the collectors of TS107 and TS108 are connected to the +40 V, C117 and R135 ensure that

high peak voltages at the inputs of IC103-4D are prevented.

The monostable multivibrator is triggered when the set is switched-off. The protection circuits described afterwards may also supply a drive signal for this multivibrator. D127, connected in parallel with S6, provides protection of TS107 and TS108 against high induction voltages in S6 if the current through this coil is interrupted.

3.2.5. Automatic tape transport stop

To stop tape transport at the end of tape and, on rewind, at the beginning of the tape automatically, metal switch-leaders are fitted at the beginning and at the end of the tape, on the non-sensitive side of the tape.

When the contacts of SK16 are closed by these leaders, the input of IC103-4D is connected to mass, via C119 and R134, so that the monostable multivibrator is activated and tape transport and, possibly, recording keys are released. After approx. 1 minute, the VCR is switched-off (see pt. 3.2.7).

3.2.6. Suppressing the tape transport stop

If the tape has been completely rewound, the metal switch-leaders will have passed the tape contact of SK16 more often than not. If in this position the start key is depressed or if switch-on is effected by the electronic clock, the switch-leader will switch-off tape transport again. To prevent this from occurring, the switching pulse is suppressed for approx. 2 minutes after switch-on of the set.

If the set is threaded-in and the start key is depressed, the cathode of D116 is connected to the +1A supply voltage, via P33, A12 and contacts 2 and 3 of SK202. Now, C128 is charged via R121 and R164.

After approx. 2 minutes C128 is charged to an extent that the "1"-level for IC103-4B is reached. Because input 6 of this NOR, via R148, is connected to mass, the output will become "0". The output of IC103-4A, operating as inverter, will therefore become "1". This voltage is applied to tape contact switch SK16, via R124, R123 and R134 achieving that this switch becomes operative only after 2 minutes.

In fastwind position, SK14 is changed over. The +1 supply voltage is then applied to input 6 of IC103-4B, via contacts 1 and 4 of SK14, P52 and R136, so that tape contact suppression is switched-off and the set can be switched-off by the switch-leader.

3.2.7. Protection against tape damages

When the set is threaded-in and no tape transport takes place, the video heads run along the same track on every revolution of the head disc. This may cause damages to the tape in spots. To ensure that this kind of damages does not occur, a protection circuit has been fitted.

This protection circuit provides switch-off of the set if, after approx. 1 minute after switch-on of the set, none of the tape transport keys is depressed.

When the start key is not depressed, point 9 of IC103-4C is connected to mass, via P33, A12 and contacts 1 and 2 of SK202. And, if none of the fastwind keys is depressed, SK14 is not changed over then, input 8 of IC103-4C is also connected to mass, via R148. As a result, the output level of this gate is "1". C120 is now charged up to this level (12 V) via R127. After approx. 1 minute, C120 is charged to an extent that the "1"-level for input 5 of

IC104-4B is reached. Because input 6 of IC104-4B normally lies at "0"-level, the output then also will become "0". The output of IC104-4A, operating as inverter, will therefore become "1".

Via D121 and R137, the monostable multivibrator for releasing the push-buttons is now activated and IC102-2B is reset via D126. As a result, the Q-output of this flip-flop becomes "0". RE101 is released and the set is threaded-out. The +1A supply voltage is switched-off, so that C120 can be discharged via D106.

However, if within 1 minute after switch-on of the set the start key is depressed, input 9 of IC103-4C is connected to the +1A supply voltage and, if one of the fastwind keys is depressed, input 8 is connected to the +1 supply voltage, via SK14. In either case output 10 of IC103-4C will become "0", so that this protection is switched-off.

C120 is now quickly discharged via D119.

3.2.8. Protection against the blocking of the capstan and the head disc

The VCR is protected against damages to the tape and to motors that may be caused if head disc or capstan get stuck.

C123 is discharged by every pulse induced in K7 by the magnets underneath the flywheel, via D125.

As this capacitor can be charged only slowly via the high-ohmic R129, the level at input 13 of IC104-4D is kept at "0" by the servo pulses.

When the capstan is blocked, the pulses on the collector of TS109 disappear.

D125 is then turned off and C123 can be charged via R129. Also when the flywheel turns much too slowly, C123 will be charged more than discharged, so that after some time the "1"-level at input 13 of IC104-4D is reached. The output of this gate now becomes "0" and, as a result, the output of IC104-4C, operating as inverter, becomes "1".

This "1"-level is applied to point 6 of IC104-4B, so that the set is switched-off.

Normally, pulses originating from the servo pulses induced in servo head K6 by the magnet underneath the head disc, are applied to P41. These pulses are applied to the base of TS111 via C133 and R128, so that by every pulse this transistor is momentarily turned on. If TS111 is turned on, C121 can be discharged via D123. As this capacitor can be charged only slowly via the high-ohmic R132, the level at input 12 of IC104-4D is kept at "0" by the servo pulses. When the head disc is blocked, the pulses on P41 disappear. TS111 then remains blocked and C121 can be charged via R132.

Also when the head disc turns much too slowly, C121 will be charged more than discharged, so that, after some time, the "1"-level at input 12 of IC104-4D is reached. The output level of this gate now becomes "0" and now also the set is switched-off.

3.2.9. Switch-off of the set in case of mains failure

This protection is necessary to prevent the set from being started when the mains returns and the tape lies around the head drum. This may cause that the tape is torn and the head disc is damaged.

When the mains drops off, also the various supply voltages disappear. However, at what speed these voltages disappear depends on the value of the load connected and the capacitances of the capacitors present in the circuit.

In case of mains failure, the voltage across C1 slowly leaks away, so that TS77 (on panel 7) is turned on. Consequently, P44 is connected to mass and, via D122, also inputs 8 and 9 of IC104-4C. Because also the load of C122 leaks slowly away via R146, the output of IC104-4C will become "1". As a result, the output of IC104-4B becomes "0" and the output of IC104-4A becomes "1".

The monostable multivibrator for releasing the push-buttons is now activated. Because C107 is not yet fully discharged then, S6 can be energized so that all keys depressed are released. The set, however, remains threaded-in.

On return of the mains voltage, the +1 supply voltage is built-up again, so that IC102-2B is reset and RE101 not energized. Because contacts 1 and 4 of SK12 are still closed, the set will be threaded-out.

Via P57 and D112, the +1 supply voltage is applied to RE102, so that this relay is energized and the +1A supply voltage available again. Via contacts 1 and 2 of RE101 and R122, this +1A supply voltage is applied to the monostable multivibrator for releasing the push-buttons, so that it is activated and all push-buttons, possibly depressed during the mains failure, are released again.

3.3. DRIVING THE FRICTION MOTOR M4 (panel 7)

The friction motor ensures that wow-and-flutter during recording and playback is limited to a minimum and that the tape is properly wound.

When the set is threaded-in, the lower reel disc is blocked by S1.

Because the friction motor M4 is coupled with the upper reel disc, M4, during threading-in, must run free in order to unwind the tape from the upper reel in the cassette. This is provided by TS78.

On switch-on of the set, the +1A supply voltage is available and C73 will be charged via R92, R93 and R94. As long as C73 is not charged yet, the base voltage of TS78 is lower than the emitter voltage and this transistor is turned on, so that C71 is charged via D88 and the +1A supply voltage is applied to the base of TS72. As a result, TS72 is cut-off, so that TS71 is also cut-off and the voltage at E32 will be approx. 12 V.

Via contacts 1 and 2 of SK9, 1 and 2 of SK10, E63, D73, D71 and R86, the +4 supply voltage is applied to E31, so that the voltage across M4 will be very low, so that this motor can run free.

If, after some time, C73 is charged up to an extent that TS78 is cut-off, then the base of TS72 is not connected to the +1A supply voltage any more. The +4 supply voltage is now applied to the voltage divider R76, R75 and R78, via SK9, SK10, E63 and D73. As a result, the base of TS72 gets a certain potential. Because both TS72 and TS71 operate as emitter-followers, the voltage at E32 will be approx. 1.4 V higher than the voltage at the base of TS72. The internal resistance and the back emf of the friction motor now determine the current through this motor and so the winding moment of the upper reel disc. Thus it is achieved that in stop position the tape is kept taut with a certain force.

If the start key is now depressed, the +4 supply voltage is switched-off. The +1A supply voltage is applied to the voltage divider R76, R75 and R78 via contacts 2 and 3 of SK202, A12, P33, P43, E42 and D74 with which is achieved that, on recording and playback, the winding

friction is very constant, so that wow and flutter is limited to a minimum and the tape is properly wound.

During rewind, SK10 is changed over. Points E63 and E42 are now voltageless, so that TS72 and TS71 are turned on and the voltage at point E32 will be 0 V approx. Because the voltage at E31 is now also 0 V, the friction motor can run free.

The +4 supply voltage is applied to the minus pole of C71, via SK9, contacts 1 and 4 of SK10 and E62, so that, via R82 and D79, this capacitor is discharged.

If the stop key is now depressed, SK10 changes over again and the voltage at E62 disappears.

C71 is charged again via R80, R81 and R85. However, as long as C71 is not yet fully charged, the voltage at the base of TS74 will be so low that this transistor is turned on. TS75 is then also turned on, so that R79 is connected in parallel with R78. As a result, the voltage on the base of TS72 decreases and therefore also the voltage at E32.

The voltage across the friction motor is then higher, with which is achieved that after depressing the stop key, on rewind, the upper reel disc momentarily gets a greater winding friction, so that tape loops are prevented.

During fastwinding, SK9 is changed over and the +4 supply voltage is applied to E31, via contacts 1 and 4 of SK9, E64, D72 and R86. This supply voltage is also applied to voltage divider R77, R78, via D77.

As a result, the base voltage of TS72 and therefore also the voltage across the friction motor are determined.

Resistors R77 and R78 are so dimensioned that during fastwinding, the current running through the friction

motor is not too high, with which is achieved that from the beginning to the end of the tape the winding friction is constant. M4 now helps winding the tape.

Because the reel discs do not stop immediately on mains failure, the winding friction has to be maintained for some time. The energy required for this is then supplied by C1.

The AC-voltage normally applied to E43 is monophasic rectified by D81 and will charge C1. Via R89, also C72 is charged. During the negative phase of the AC-voltage at E43, C72, via D84 and R88, will always be so discharged that the base voltage of TS77 cannot become high enough to drive this transistor into saturation.

If, during a mains failure, the voltage at E43 disappears, capacitor C72, via R89, will be charged from the load of C1 to an extent that TS77 is turned on, so that E44 is then connected to mass. As a result, TS76 is turned on.

The collector current of this transistor runs via the friction motor and D82, with which is achieved that the winding friction remains intact until C1 is discharged.

On return of the mains, the set will be threaded-out.

The +1 supply voltage is then applied to the anode of D87, via P45 and E41. As a result, the delay circuit made up of R92, R93, R94 and C73, will be switched-off, so that, on return of the +1A supply voltage, TS78 remains cut-off, so that, during threading-out, the tape can be wound again. On switch-off of the set, C73 is discharged, via R94 and D86.

4. ELECTRONIC CLOCK (circuit diagram D)

Using the electronic clock, the VCR may be switched on and off at a preset time. The period of presetting the switch-on of the set is 3 days maximum.

4.1. CONTROL

The electronic clock may be set using the two push switches SK321 and SK322 and slide switch SK323. In position 1 of SK323 (lock), the time-of-day counter is activated. The +1 supply voltage is then applied to inputs 5 and 6 of IC323-4B so that the output of this gate is "0" and setting the clock is not possible then. In position 2, 3 or 4 of SK323, the start time counter, the period counter or the day counter resp. are activated. Because, via R333, the inputs 5 and 6 of IC323-4B are connected to mass now, the output of this gate will be "1". This "1" is applied to the common point of SK321 and SK322, for slow or fast setting of the counters. In position 5 of SK323 (set clock), the time-of-day counter is also activated, but may be set, using SK321 or SK322. Because there is no debounce circuit available for the fast set input of IC321, C323 and R328 have been added. When the set is connected to the mains or after a mains failure, the LED's in D321 start flashing in a 2 Hz rhythm. This flashing is meant as a warning signal. The two push switches SK321 and SK322 have to be pushed in simultaneously, so that the clock is set to 12.00, after which the time may be set in the normal manner.

4.2. CLOCK LOGIC (IC321)

IC321 contains the total logic required for operating the clock. To show the functional operation as clearly as possible, the block diagram of IC321 shows the main functions and connections only. IC321 may be driven either by a 50 and a 60 Hz reference signal. Because a 50 Hz signal is used, point 30 of IC321 is open, so that the 1:5 or 1:6 divider operates as a 1:5 divider. The 10 Hz signal at the output of this divider is supplied to a 1:5 divider. The 2 Hz output pulses of this divider are applied to the display select and set logic, where these pulses are used for slow setting of the clock and for letting the display flash in a 2 Hz rhythm if there has been a mains failure. These 2 Hz pulses are also used for driving a 1:120 divider, so that 1-minute pulses are present at the output of this divider. These 1-minute pulses are also applied to the display select and set logic, where they are used to drive the time-of-day and/or the period counter. The latch input, all display inputs and the set inputs are connected to mass via built-in resistors, so that these inputs are activated when they are connected to the +1 supply voltage. With the exception of the fast set input, these inputs are connected to a key debounce circuit. This to suppress contact clicks. The latch is a trigger flip-flop that changes over at every positive slope on the input. The output signal of the latch is applied to point 25 and to the electronic switch. If none of the display inputs is activated, the 1-minute pulses are applied to the time-of-day counter, so that after every minute it will take one step. When position 23.59 is reached, the counter will be reset to 00.00 at the next pulse.

The start time counter is activated by connecting point 33 of IC321 to the +1 supply voltage. This counter then operates as the time-of-day counter. The period counter is activated by connecting point 28 of IC321 to the +1 supply voltage. Because point 23 of IC321 is connected to the +1 supply voltage, this counter will be set in position 2.00 and count down one step at every 1-minute pulse. When position 00 is reached, this counter will be reset to 2.00 at the next 1-minute pulse. The day counter is activated by connecting point 34 of IC321 to the +1 supply voltage. By connecting the slow set input to the +1 supply voltage, this counter will count down from 3 to 0 in a 2 Hz rhythm. When the time-of-day counter is reset from 23.59 to 00.00, the day counter will be set back one step until position 0 is reached. The other 3 counters may be set both slow, with 2 Hz, and fast, with 50 Hz, by connecting the slow set or the fast set input resp. to the +1 supply voltage. The outputs of the four counters are connected to the segment decoder, where the information from these counters is so translated that the right LED's in D321 light up. The output drivers ensure that sufficient power is supplied to make the LED's light up. The reading of the time-of-day counter is continuously compared with the reading of the starting time counter by the comparator. When the readings of these 2 counters are the same, one of the switch-on conditions of the electronic switch is satisfied. If the reading of the day counter is 0 and the output of the latch is high, then all switch-on conditions are satisfied and the switch-output will become high. Now, the period counter is also activated. This counter shows the preset time and will be set back 1 step at every 1-minute pulse. When position 00 is reached, the time-of-day counter will be activated again at the next 1-minute pulse, and because in non-activated position, this counter is yet always driven by the 1-minute pulse, this counter will read the right time-of-day again. The output of the electronic switch will remain high during the preset time of the period counter. When this counter has reached the 00 position, the switch output will become low at the next 1-minute pulse and the latch will change over, so that the latch output also becomes low.

4.3. DISPLAY (D321)

Reading the time-of-day, the start time, the switch-on time and the day is provided by D321. It contains 4 groups of 7 LED's. Every group can form every figure desired, by making the right combination of LED's light up. These LED's are directly driven by IC321. The cathodes of each group are interconnected and connected to mass via R321, R322 and R323. These resistors operate as current limiters for IC321 (the current through these resistors is approx. 5 mA per segment).

4.4. ACTIVATE

The electronic clock is set to activate position by depressing the start key. A positive voltage is then applied to connector point D15, via contacts 15 and 16 of

SK202 (see diagram C), so that points 2 and 6 of IC322 become "1".

The latch output (point 25 of IC321) is still low then and therefore also points 1 and 13 of IC322. Point 3 and also points 5 and 12 of IC322 then become "1", so that the output of IC322-4D will become "1" and the output of IC322-4B becomes "0". These two outputs are connected to the inputs of IC322-4C, so that the output of this gate will become "1".

As a result, the latch in IC321 is activated, so that the latch output will become "1". Inputs 1 and 13 of IC322 are now also "1", so that the output of IC322-4A becomes "0". Because points 5 and 12 of IC322 are also "0" now, the outputs of IC322-4D and IC322-4B both become "1", so that the output of IC322-4C becomes "0".

Because only positive slopes on the input of the latch may trigger it, the clock will remain in activated condition.

If the stop key is depressed now, then D15 is switched off, via SK202. Via R326, input 2 of IC322-4A is connected to mass. The latch output of IC321 is still high now, so that the output of IC322-4D becomes "1". Consequently, the output of IC322-4D becomes "0" and the output of IC322-4B remains "1".

As a result, the output of IC322-4C will become "1", so that the latch is triggered and the latch output will become "0".

As a result, points 1 and 13 of IC322 are also "0" and the output of IC322-4A remains "1". The output of IC322-4D therefore becomes "1", whilst the output of IC322-4B remains "1". Consequently, the output of IC322-4C becomes "0". The latch is therefore not triggered, so that the clock remains in non-activated condition.

4.5. PROLONGATION OF SWITCH-ON PERIOD

When the set is switched on by the electronic clock while SK323 is in the position "lock", the set will be switched off again after expiration of the adjusted switch-on period. If SK323 is in a position other than "lock", the set will not be switched off by the electronic clock. The set will then be switched off by the stop foil at the end of the tape (see para 3.2.5). In the position "lock" of SK323, the output 4 of IC323-4B is "0", so that the output 3 of IC323-4A is "1".

If the clock has not yet been activated (the start button not yet depressed), the input 9 of IC323-4C is connected to mass via R327, so that the output of this gate is "1". Consequently, the input 12 of IC323-4D is also "1" and, because the input 13 is also "1", the output of this gate will be "0", so that TS321 does not become conductive. If the switch output of IC321 becomes "1", a positive voltage is applied, via D323, to the base of TS321, with the result that this transistor becomes conductive and the set is switched on. The switch output of IC321 is also connected to the input 1 of IC323-4A, but because a "0" is applied to the input 2, the output of this gate will remain "1".

The switch output of IC321 becomes "0" when the switch-on period has expired. TS321 will then be cut off and the set is switched off.

If SK323 is in a position other than "lock", the output 4 of IC323-4B will be "1". If the switch output of IC321 also becomes "1", the set will be switched on via TS321 and the output 3 of IC323-4A will become "0". As a result, the output 11 of IC323-4D becomes "1" and, because the input 9 of IC323-4C is then also "1", the output of this gate will become "0".

Once the switch-on period has expired, the switch output of IC321 becomes "0", so that the output 3 of IC323-4A becomes "1". The input 12 of IC323-4D is still "0", so that the output of this gate will remain "1" and a positive voltage is applied, via R331, to the base of TS321. As a result, the set will remain switched on.

4. ELECTRONIC CLOCK (Circuit diagram D)

The following description is valid for apparatus from factory code 817. These apparatus are fitted with the changed panel 32.

4.1. Operation

The electronic clock can be adjusted with the push switches SK321 and SK322 and the slide switch SK323. In position 1 of SK323 (lock), the time-of-the-day counter is activated and the +1 supply voltage is applied to input 12 of IC322 via R331. Because input 13 of IC322 is connected to the +1 supply voltage, IC322-4D will operate as inverter, so that the output level at point 11 is now low. The common point of SK321 and SK322 is therefore also low, so that the clock cannot be set now.

In position 2,3 or 4 of SK323 the starting time counter, the period counter or the day counter resp. are activated. Now, input 12 of IC322 is connected to mass via R331 and R333, so that the output level of IC322-4D is high and the counter selected can be set slowly or fast using SK321 or SK322.

In position 5 of SK323 (set clock) the time-of-the-day counter is activated and can be adjusted using SK321 and SK322.

Because for the fast-set input of IC321 no debounce circuit is built-in in IC321, C323 and R328 have been added.

When the apparatus is connected to the mains or after a power failure, the LEDs in D321 will light up in a 2 Hz rhythm. This lighting up functions as a warning signal. The two push switches SK321 and SK322 must then be pressed simultaneously, so that the clock is set to the 12:00 position and the normal time can be set.

4.2. Clock logic (IC321)

See the description on page II-27.

4.3. Pulse shaper (IC322-4C)

The pulse shaper is formed by IC322-4C. Via connector point D12 an AC-voltage with a frequency of 50 Hz is applied to filter R324, C322. This filter serves to suppress HF-mains interferences.

Because input 9 of IC322-4C is connected to mass this gate operates as buffer.

By feedback of the output signal via R332 is achieved that the voltage at connector point D12 is approx. 20 V lower when the output level of IC322-4C goes from high to low than from low to high. Besides, the edges of the output signal will be very sharp (< 50 μ sec), see Fig. II-14. Thus, a good protection against interference signals on the mains is achieved.

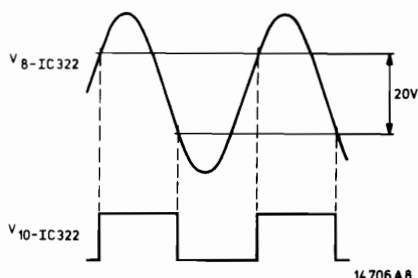

Fig. II-14

4.4. Display (D321)

The indication of the time of the day, the starting time, the switching-on time and the day is performed by D321. In it, 4 groups of 7 LEDs are applied. By lighting up of the right combination of LEDs, any figure desired can be formed in each group. These LEDs are driven directly from IC321. The cathodes of each group are interconnected and connected to mass via R321, R322 and R323. These resistors operate as current limitation for IC321 (the current through these resistors is approx. 5 mA per LED).

The colon in D321 will always light up when a time is shown. In position "day" of SK323 the colon will not light up. Input 13 of IC323 is then connected to the +1 supply voltage via SK323 so that the output level at point 10 is low. TS322 is therefore cut-off and the colon does not light up.

If now the electronic switch in IC321 is switched, the period time will be indicated by D321 and the level at input 2 of IC322 becomes high. As a result, the output voltage of IC322-4A is low, so that the output voltage of IC323-3C is high and TS322 is turned on. So, the colon now lights up.

The current through the colon is limited by R334 (it is approx. 5 mA per point).

4.5. Activate (IC322-4B)

The electronic clock is automatically set to position "activate" when the start button is pressed. Connector point D15 is then connected to a positive voltage via contacts 12 and 13 of SK202 (see diagram C), so that the level at input 5 of IC322 becomes high.

Because now the latch output (point 25 of IC321) is still low, output 4 of IC322 and therefore also the latch input (point 24 of IC321) will become high. The latch in IC321 is formed by a T-flip-flop, so that the output level changes at every positive going slope on the input.

As a result, the latch output is now high, so that also input 6 of IC322 is high. Therefore, the level at output 4 of IC322 will become low again.

Now, a stable situation is achieved and the electronic clock is activated.

If the stop button is pressed now, the connection of connector point D15 with the supply voltage is interrupted. Input 5 of IC322 is connected to mass via R327. The level at output 4 of IC322 becomes high, so that the latch in IC321 is switched over and input 6 of IC322 becomes low. The output level at point 4 of IC322 becomes low again, so that the clock remains in the non-activated position.

4.6. Switch-on logic

If the apparatus is switched-on by the electronic clock with SK323 in "lock" position, the apparatus is switched-off again after the duty cycle has elapsed. With SK323 in another position than "lock", the apparatus is not switched-off by the clock, but will be switched-off by the stop strip at the end of the tape (see point 3.2.5.).

With SK323 in "lock"-position, output 11 of IC322 is low, so that also the input level at point 3 of IC323 is low. As a result, output 6 of IC323 is high.

If the switch output (point 26) of IC321 is still low, point 2 of IC322 will also still be low. Because point 1 of IC322 is connected to the +1 supply voltage via R330, IC322-4A operates as inverter, so that the output level at point 3 will still be high. Inputs 1, 2 and 8 of IC323 now are all high, so that the output level at point 9 is low. The base voltage of TS321 is therefore also low, so that this transistor is cut-off.

If now the switch output of IC321 becomes high, the output level at point 3 of IC322 becomes low. Because the inputs 1 and 2 of IC323 are also low now, output 9 becomes high. TS321 is turned on now, so that the apparatus is switched-on.

After the duty cycle of the clock has elapsed, the voltage at the switch output of IC321 will become low. The level at output 3 of IC322 is now high, so that also inputs 1 and 2 of IC323 are high. Output 9 of IC323 therefore becomes low, so that TS321 is turned off and the apparatus is switched-off.

With SK323 in another position than "lock", point 12 of IC322 is connected to mass via R331 and R333, so that the level at output 11 of IC322 and so also at input 3 of IC323 is high.

When the switch output of IC321 becomes high, the apparatus is switched-on in the manner described above. Because now inputs 3, 4 and 5 of IC323 are all high, output 6 becomes low.

Input 8 of IC323 is therefore also low, so that output 9 remains high, also when inputs 1 and 2 of IC323 become high again.

So, the apparatus remains switched-on also when the duty cycle adjusted has elapsed.

III. SERVICE ADJUSTMENTS AND LUBRICATING INSTRUCTIONS

	Page
1. Electrical adjustments	
1.1. Signal section (circuit units not included)	III-3
1.2. Signal section (circuit units)	III-5
1.3. Servo system	III-7
1.4. Supply voltages	III-8
1.5. Adjusting motor control M4	III-8
2. Mechanical adjustments and checks	
2.1. Uncasing	III-11
2.2. Tape deck	III-11
2.3. Switches	III-14
2.4. Lace-up	III-15
3. Lubricating instructions	III-19

1. ELECTRICAL ADJUSTMENTS

1.1 SIGNAL SECTION (CIRCUIT UNITS NOT INCLUDED)

1.1.1. R711 (high-pass filter)

● *Method 1*

- Make a recording of the test pattern VCR/BL-W of PM5509.
- Playback this recording
- Adjust R711 so that the definition lines in the fifth bar from the top (approx. 3,07 MHz) become just visible. However, if short, black stripes now appear in the overhead definition bars, then adjust back R711 to an extent that these stripes disappear.

● *Method 2*

- Playback the premodulated service test cassette 4822 397 60046.
- Adjust R711 so that the 3 MHz definition lines in the test pattern (Fig. III-4) are just visible.

Remark:

After exchanging the head disc, check the above mentioned adjustment.

1.1.2. R710 (Adjusting the chrominance writing current)

- Tune recorder to colour bar pattern produced by a pattern generator.
- Recorder in position RECORDING with inserted cassette.
- Connect oscillograph to 3U731
- Switch off FM modulator by connecting 17U731 to mass.
- Adjust with R710 the amplitude of the chroma signal for $110 \text{ mV} \pm 5 \text{ mVpp}$.
- Remove short-circuit of 17U731 to mass.

Note:

- For checking the luminance writing current see section 1.2.14 of this chapter.
- If unit U515 is exchanged, the chrominance writing current has to be checked.

1.1.3. C509 (8,86 MHz oscillator, recording)

- Tune the VCR to the red pattern produced by a pattern generator.
- Short circuit junction C516-C517 to chassis.
- Connect the YA-input of the oscillograph to the CVBS output of the pattern generator.
- Trigger the oscillograph on the YA-input (adjust the time base of the oscillograph so that the sine periods of the burst signal are separately visible.
- Connect the YB-input to 16U515 (test point K44).
- Adjust C509 so that the sine signal on the YB-input stands still.

1.1.4. C523 (4.43-MHz oscillator, Play-back)

- Recorder in position playback.
- Connect YA input of oscillograph to CVBS output of pattern generator (red pattern).
- Trigger oscillograph to the Y-A input. (Adjust the time base of the oscillograph so that the sinusoidal periods can be observed separately).
- Connect YB-input to 16U515 (test point K44).
- Adjust C523 in such a way that the sine signal at the YB-inputs stands still.

1.1.5. S504 (5.5 MHz filter, sound)

- Tune VCR to pattern generator.
- Modulate sound carrier on pattern generator.
- Connect a millivoltmeter to 9U508 (test point L23).
- First, adjust for maximum output voltage of the pattern generator. Next, decrease the output voltage to an extent that the output voltage at 9U508 slightly decreases. (The amplitude of the IF-sound signal becomes lower than the limiter level in U508).
- With cores a and b of coil S504 adjust for maximum output voltage at 9U508. If necessary, reduce the output voltage of the pattern generator if the IF-sound signal surpasses the limiter level again.

1.1.6. S505 (5.5 MHz-filter, Phaft)

- Tune the VCR to a checker board pattern of a pattern generator (do not use channel selector push button 8)
- Band selector switch in drawer (panel 34) to band III position. Do not modulate the sound carrier.
- Make a test array as shown in Fig. III-3.

● *Hints*

- Open the solder bridges SP501 and SP502 in the print track (see Fig. III-4).
- Disconnect R505 on one side.
- Disconnect C510 on one side.
- The 22 μF capacitor must be connected to the output of the time-base generator in the oscillograph. This output is at the back of the oscillograph.
- Adjust the time-base of the oscillograph to 10 ms/div.
- Connect the Y-input (DC) of the oscillograph to 2U508.
- Adjust the 1 M Ω trimming potentiometer in such a way that an S-curve appears on the oscillograph screen.
- Adjust the trimming cores a and b so that the S-curve is as symmetrical as possible and symmetrical with respect to the zero-axis crossing.

Remark

The S-curve can be slightly influenced by:

- The output voltage of the pattern generator (most favourable output voltage approx. 1 mV.)
- The patterns on the pattern generator. The most favourable pattern for the PM 5508 is the cross-hatch pattern).
- 1 The most favourable pattern for the PM 5509 is the circle pattern.

1.1.7. S507 (Adjusting the bias)

- Connect a millivoltmeter between measuring plugs L16 and L15 (L15 is chassis)
- Insert cassette (cassette switch SK17 must be closed)
- VCR in recording position
- Connect L12 to chassis
- Witch the core of S507, adjust the bias voltage to 70 mV

1.1.8. S705, S706 (chroma suppression filters)

- Remove plug F2 from panel 71.
- Connect a HF-generator between F21 and F22 (mass).
- Connect a millivoltmeter to 2U732.
- Adjust the frequency of the HF-generator to 562,5 kHz, output voltage 50 mV.
- Adjust S706 to minimum millivoltmeter reading.
- Adjust the frequency of the HF-generator to 590 kHz, output voltage 50 mV.
- Adjust S705 to minimum millivoltmeter reading.

1.2. ADJUSTMENTS IN SIGNAL SECTION (CIRCUIT UNITS)

Note:

All adjustments in the circuit units have been carried out very carefully in the factory. Also pre-adjustments have been performed.

Below we shall mention only those adjustments which must be checked when a unit is replaced. Besides, we shall describe a checking procedure of some important adjustments which in principle need not be checked.

1.2.1 U505 (IF unit)

No service adjustments required.

1.2.2. U506 (IF detector unit)

No service adjustments required.

1.2.3. U507 (AGC unit)

No service adjustments required.

Note:

When a strong local transmitter is received, it may be necessary to change the HF AGC adjustments slightly. Then readjust R11 in U507 so that the picture is displayed without distortion.

1.2.4. U508 (IF sound + Phaft unit)

No service adjustments required.

Remark:

After exchanging U508 or transistor TS507, it may be necessary to carry out the following check:

- Tune the VCR to a TV-transmitter (preferably in the low UHF-range), do not use channel selector push-button 8.
- Check that the tuning of the VCR with and without Phaft is the same.
- Corrections are made with R14 in U508. Phaft has to be switched-off then by connecting junction R502, C502 to the +5 supply voltage.

1.2.5. U512E (562.5 kHz processor)

No service adjustments required.

1.2.6. U513E (reference processor)

- Burst-key adjustments.
 - . Tune the VCR to the colour bar pattern of a pattern generator.
 - . Connect an oscilloscope to 2U514
 - . R7 in U513E to be so adjusted that the amplitude of the chroma signal at 2U514 is minimum.

1.2.7. U514 (Chroma filtering)

No service adjustments required.

1.2.8. U515 (Chroma AGC-mixer)

- Adjusting the chroma amplitude
 - Tune the VCR to a colour signal
 - Connect an oscilloscope to 2U514
 - The burst amplitude at 2U514 should be 600 mVpp.
 - Adjustments with R21 in U515.

1.2.9. U531 (signal preparation for UHF-modulator)

No service adjustments required.

- *Checking the output voltage for FM modulator U731*
 - Tune the VCR to the white pattern of a pattern generator
 - The output voltage at 11U531 should be $2,1 \pm 0,2$ Vpp (sync. positive going)

1.2.9.1. U532 (562.5 kHz processor)

● *Burst-key adjustment*

- Tune the VCR to the colour bar pattern of a pattern generator.
- Connect an oscilloscope to 2U514.
- R6 in U532 to be so adjusted that the amplitude of the chroma signal at 2U514 is minimum.

1.2.9.2. U533 (reference processor)

No Service adjustments required.

1.2.10. U539 (audio processor)

No service adjustments required.

1.2.11. U551 (UHF-modulator)

● *Checking the modulation depth (video)*

- Starting position: Combination TV-VCR
- Tune the VCR to a grey scale pattern of a pattern generator.
- Also tune the TV-receiver to the grey scale pattern of the pattern generator using another channel selector push button.
- The contrast ratio of the looped-trough VCR signal should be the same as the signal received directly by the TV-set (only via the aerial amplifier in the VCR).
- Adjustments with R311 in the UHF-modulator.

● *Detuning of the modulator carrier frequency*

- General
 - The modulator carrier frequency has been factory-adjusted to 600 MHz (channel 37). When there are interferences between the modulator carrier and a local transmitter the modulator must be tuned to a vacant channel.

Adjusting method when modulator carrier frequency has to be tuned to another frequency.

- Starting position: combination of TV-VCR. TV tuned to modulator frequency of VCR.
- Apply colour bar pattern from a pattern generator to aerial input of VCR. Select frequency of applied signal preferably in VHF range - for example, channel 8.
- Tune VCR to applied signal.
- Connect instead of pattern generator an outdoor aerial to VCR.
- If then a transmitter is received by TV, detune TV until transmitter is not received any more. Do not detune more than about 5 channels.
- Reconnect pattern generator to aerial input of VCR.
- Adjust C453 on the modulator unit so that a correctly tuned picture is displayed on TV.

Notes:

The TV set must be tuned to upper side-band of modulator signal.

If the modulator frequency must be increased, turn out the core of C453. To decrease this frequency, turn in the core.

1.2.12. U552 (aerial amplifier)

No service adjustments required.

1.2.13. U553 (channel selector)

No service adjustments required.

III-6b, N1700, N1702

1.2.14 U731 (FM recording processor)

No service adjustment required.

● *Checking the luminance writing voltage*

- Tune the VCR to a white-pattern produced by a pattern generator.
- Cassette in recorder.
- Connect oscillograph to 3U731
- VCR in position recording.
- The luminance writing current should be 0,8 V \pm 0,05 Vpp (adjusted with R27 in U731).

1.2.15. U732 (U702) (FM playback processor)

No service adjustments required.

● *Checking the drop-out compensator switch-on level*

- Playback test pattern of premodulated service test cassette 4822 397 60046.
- In the drop-out test signal the fields 1 and 3 must be black and the fields 2 and 4 white (Fig. III-4).
- The switch-on level is adjusted with R22 in U732 (R8 in U702)

Note:

- When U732 (U702) is exchanged, the residual carrier suppression in U734 must be checked (see 1.2.16).

1.2.16. U734 (FM demodulator)

● *Adjusting the residual carrier wave suppression.*

- Connect an oscillograph to 1U734
- Playback a recording.
- With R4 in U734, adjust residual carrier wave signal to minimum.

Remark:

- The most favourable spot in the video signal for adjusting to minimum residual carrier wave is the back porch of the line pulse.

● *Checking the output voltage*

- Record a white pattern produced by a pattern generator.
- Playback the recording.
- Connect oscillograph to 1U734
- Output voltage on 1U734 must be 2.5 Vpp. (Adjustable with R15 in U734).

1.3. ADJUSTING THE SERVO-SYSTEM (PANEL 21).

General

- Recorder should be in horizontal position.
- VCR in recording position, unless otherwise indicated.
- No cassette inserted, unless otherwise indicated.
- The adjustment components are fitted in the units and accessible from above, as shown in the drawing.
- The 2 taps - bottom left - can be broken off and then serve to block the switches SK201 and SK202 with panel 21 hinged out.
- By inserting a piece of wire of e.g. a resistor, from the track side of the PC-board through the corresponding hole, the test points of the test blocks B3 and B4 are within easy reach.

1.3.1. Adjusting the head servo system (U219)

a. Position of the picture gap.

- Make a recording of a white pattern and play it back.
- Connect an oscillograph to L21 (panel 51).
- Trigger the oscillograph externally with the signal on B43 (time base x5).
- The picture gap must be visible between 2 to 12 line durations before the frame pulse.
- Should the picture gap occur earlier or later, then adjust R9 of U219 as follows:
- Connect an oscillograph to B41 and trigger externally with the signal on B43.
- On the picture screen of the oscillograph the scanning pulse is now visible.
- Is the picture gap e.g. 3 line durations (= 192 μ sec) too early (further away from the frame pulse) then the scanning pulse should be moved 3 line durations to the right. Adjustments with R9 of U219.
- Is the picture gap e.g. 3 line durations too late (closer to the frame pulse) then, with R9 of U219, move the scanning pulse 3 line durations to the left.
- Make a new recording of a white pattern and play it back
- Check the picture gap again and, if necessary, correct the adjustment of R9 of U219 as indicated above.

If a stroboscope is available, the following method can be applied:

- Remove the cassette lift
- By hand, move bracket 522 to the left and block it, e.g. with one of the tags of panel 21.
- Switch on the recorder and, by hand, push down bracket 545 for a moment and press the playback and the recording key.
- Apply the signal of a pattern generator to the VCR.
- Connect the trigger input of the stroboscope to the sync. output (frame) of the pattern generator.
- Light the head disc with the stroboscope
- The video heads are now visible near the last mounting screw of the drum ruler.
- Adjust R9 of U219 in a way that, measured in rotation direction of the head disc, the distance between the mounting screw and the gap of the video heads is 4,2-5,3 mm (see Fig. III-1).
- Refit the cassette lift.

b. Ripple voltage

- Connect an oscillograph to B31
- Set R2 of U219 to minimum ripple in the oscillogram shown.

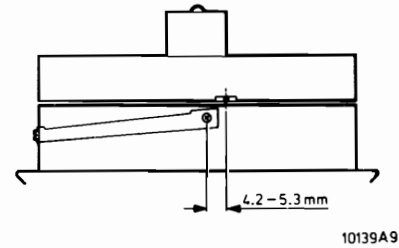

Fig. III-1

1.3.2. Adjusting the tape servo system (U230)

a. Flywheel pulse

- Connect an oscillograph to P13.
- Adjust the distance between servo head K7 and the magnets on the flywheel in such a way that the peak-to-peak value of the oscillogram is 400-600 mV.

Remark:

When replacing K7 please note the polarity of the pulse given (see Fig. III-2).

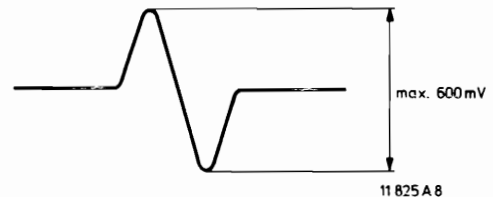

Fig. III-2

b. Position detector

- Connect the Y-A input of a double-beam oscillograph to B42.
- Connect the Y-B input to B43
- Trigger the oscillograph to the positive going edge of the signal on the Y-B input
- Adjust R7 of U230 in such a way that the distance between the negative going edge of the scanning pulse on B42 and the positive going edge of the reference pulse on B43 is $4 \pm 0,5$ msec.

c. Ripple voltage

- Connect an oscillograph to B32
- Set R3 of U230 to minimum ripple in the oscillogram shown.

1.3.3. Zero point adjustment of the tracking (U237)

- Play back an own recording.
- Set the tracking control to its mid-position.
- Connect the Y-A input of a double-beam oscillograph to B43.
- Connect the Y-B input to point 9 of U237.
- Trigger the oscillograph to the signal on the Y-A input.
- Adjust R38 of U237 in such a way that the negative going edges of both signals coincide (tolerance: $\pm 1,5$ msec).

Remark:

This adjustment is required only if U237 or R95 has been exchanged.

1.4. ADJUSTING THE POWER SUPPLY SECTION (Panel 11).

1.4.1. Set to the mains voltage required

- All recorders, except the /15, are set to a mains voltage of 220 V by the factory, the /15 is set to a mains voltage of 240 V.
- When another mains voltage is required, please see the sticker at the chassis bottom.
- The strips with possible mains voltages can be torn off and stuck on the type plate at the back of the recorder.
- Under codenumber 4822 401 10632 a cable binder is supplied to tie together the wires of the primary windings of the transformer.

Remark:

Always observe the national security safety regulations.

1.4.2. Adjusting the + 1 supply voltage

After repairing the +1 supply voltage on panel 11, the supply voltage should be checked.

If the supply voltage exceed the tolerance ($12 \pm 0,1$ V), readjustments of the stabilizer as follows:

- VCR in recording position.
- From the following series of resistors, choose values for R107 and R108 so that the +1 voltage is $12 \pm 0,1$ V.
- Choice series R107-R108: 47 k Ω - 56 k Ω - 82 k Ω - 100 k Ω - 150 k Ω - 270 k Ω - 680 k Ω .

All resistors mentioned are standard 5% - 1/8 W carbon resistors.

1.5. ADJUSTING MOTOR CONTROL M4 (panel 7)

Adjusting the counter frictions

- VCR in stop position
- Cassette inserted
- Connect a DC-voltmeter across R86 (+pole to E31).
- With R75, adjust for a meter reading of $150 \text{ mV} \pm 5 \%$.

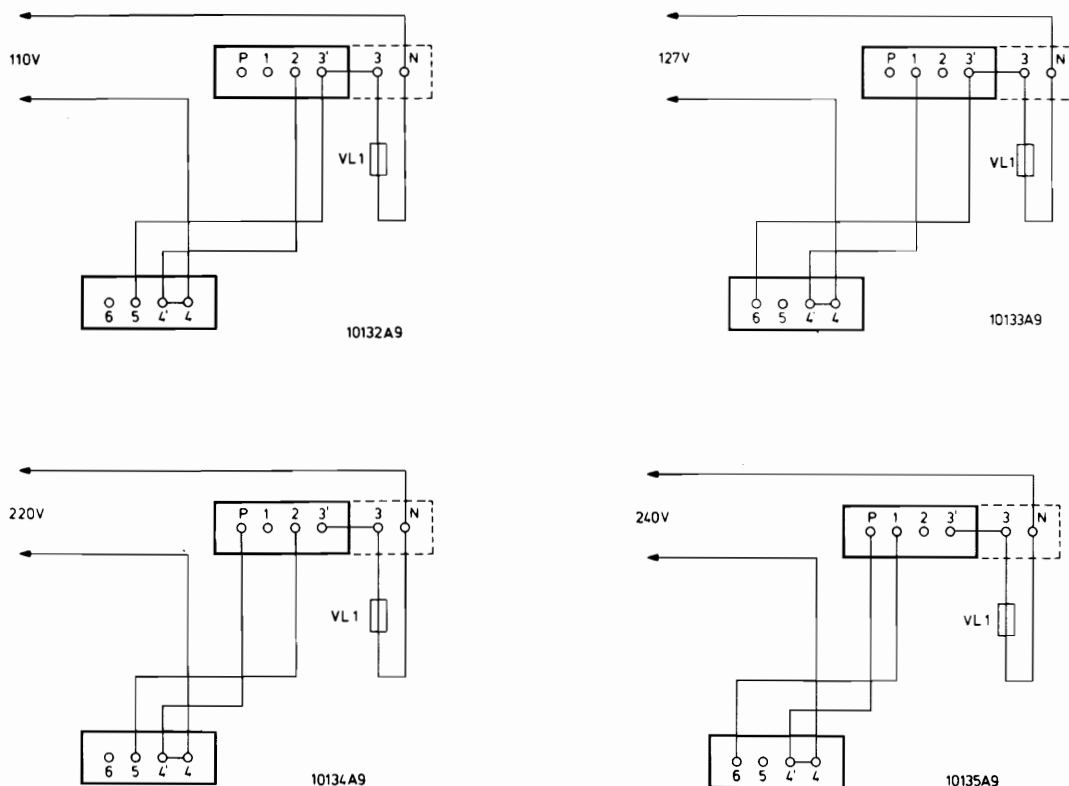
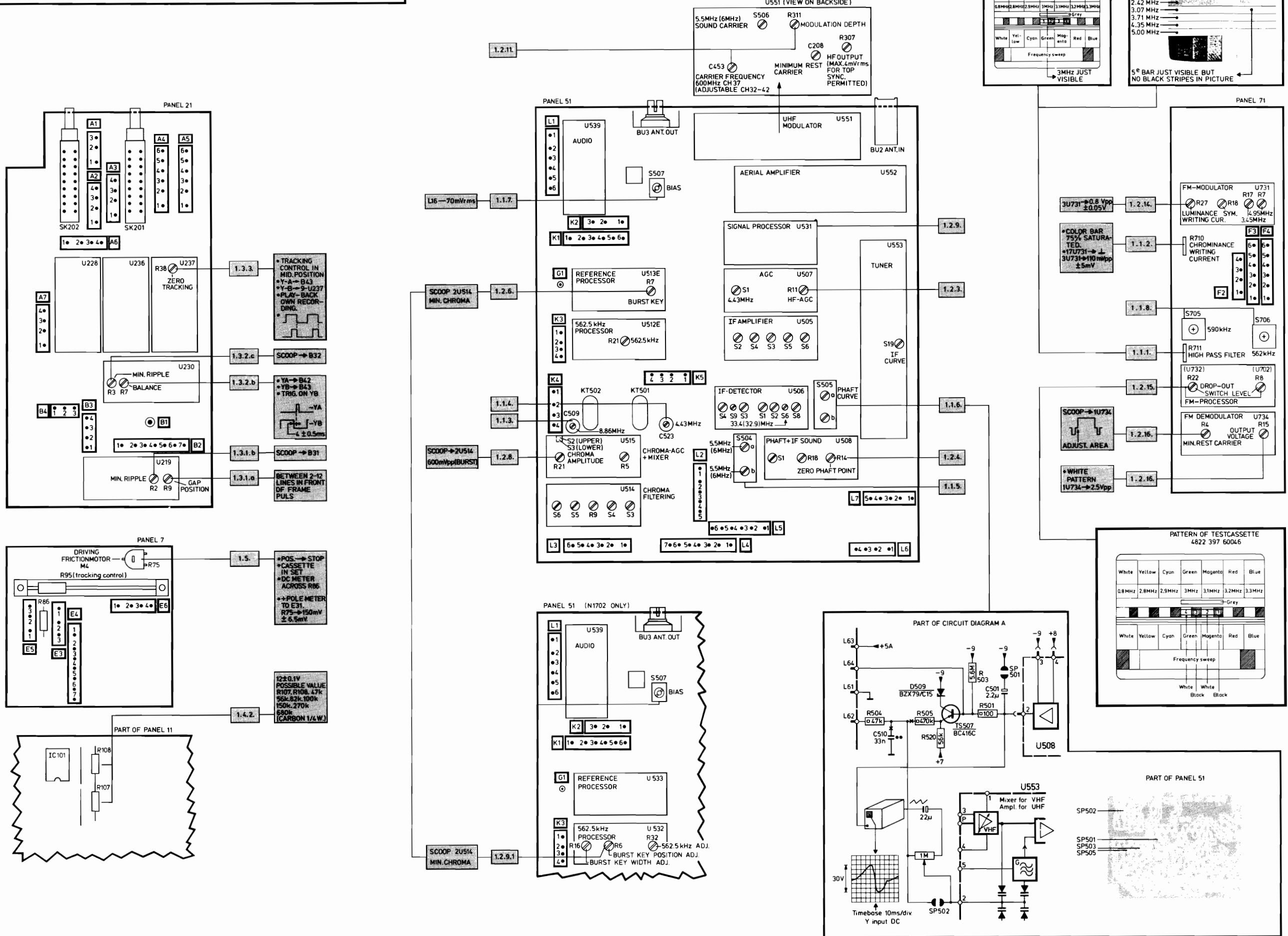

Fig. III-3

ADJUSTING DIAGRAM



2. MECHANICAL ADJUSTMENTS AND CHECKS

2.1. UNCASING

2.1.1. Cover plate 103

- Fully unscrew screws 127 at the back of the apparatus. These screws cannot be separated from the apparatus.
- Slightly lift the cover plate and push it backwards.

Remark:

In sets from production code 735 on, the two corners at the front of the cover plate must be pushed both upwards and to the back (see Fig. III-5).

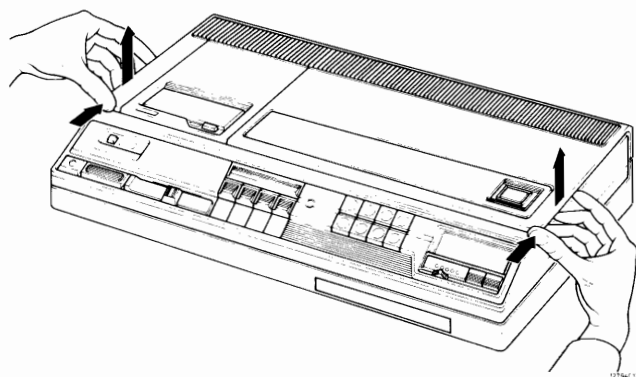

Fig. III-5

2.1.2. Cassette holder cover 101

- Remove screws 8 (2x).
- The cassette holder cover can now be lifted out.

Remark:

When remounting the cassette holder cover, take care that the tags on the right hand side of the holder fit into the corresponding slits of the cover.

2.1.3. Front frame 107

- Remove screws 20 (5x). Four of these screws are located in the sides of front frame 107, the fifth is accessible when the recording key is pressed.
- Front frame 107 can now be taken out.

Remarks:

- The panels 30, 31 and 32 are mounted in this frame so that it can be fully removed only if the wiring to these panels is detached.
- When remounting front frame 107, take care that knob 105 fits in the right manner on the tag of slide potentiometer R95.

2.1.4. Bottom plate 120

- Set the apparatus on its back.
- Remove the two fixing screws on the bottom plate.
- Using a screwdriver, push down the 2 locking tags of the bottom plate.
- The bottom plate can now be removed.

Important:

When remounting the bottom plate, the 2 fixing screws must be fitted again (safety).

2.1.5. Cassette holder 191

- Open the cassette holder by pressing the eject key.
- Push down the cassette holder to an extent that the pin of bracket 193 is opposite the opening in the cassette holder.
- Block bracket 193 by hand.
- The cassette holder can now be lifted out.

Remark:

When remounting the cassette holder it suffices to place it into the brackets 214 and 220 and push it down. It will be locked automatically.

2.2. TAPE-DECK

Remarks:

- On playback without cassette holder, interference may be visible on the screen. This is caused by static discharge. Normally, this load is discharged via carbon brush 212 in the cassette holder.
- Removing the switches. The microswitches used in the apparatus are mounted by means of spring plates. The switches can be demounted by depressing these plates and pushing them away. When remounting, take care that the pin on which the switch sits is behind the barbed hooks on the plate.
- The apparatus can be used without cassette holder if:
 - a. Spring 192 is taken off bracket 193. The pin on bracket 193 must be fully pressed against the chassis.
 - b. SK11 is switched over. This can be done by blocking bracket 522 in its right hand position by placing an object between this bracket and SK11.
 - c. Before pressing one of the tape transport keys, bracket 545 must be pushed down by hand.

Important:

The rotating plane of lower drum 184 is in parallel with the plane on which the cassette sits. This has been effected by mounting rings in varying thicknesses underneath the drum guide rollers (marked ● in Fig. III-6). When demounting the guide rollers or the lower drum, it is advisable to mark the rollers and the appropriate rings, as otherwise, on remounting, the parallel adjustment has to be carried out again.

2.2.1. Checking the threading-mechanism

- Loosen screws A of rack 271 a few turns (see Fig. III-6) and push the rack entirely to the right.
- Loosen screws B of the threading-unit a few turns and turn this unit to the right to an extent that its gear is no longer in touch with the gear ring of the lower drum.
- By rotating the lower drum by hand, check that it runs through the guides smoothly and without play.
- If not, drum and guide wheels must be checked.
- By turning the threading-unit, its gear must be reinserted in the gear ring of the lower drum.
- The threading-unit must be so adjusted that the teeth of gear and gear ring interlock as far as possible although some play must be provided for.
- Check that the lower drum runs smoothly and without play when turned by hand.

- Rack 271 must be so adjusted that its teeth and those of the gear of the threading-unit interlock as far as possible, although a just discernable play must be provided for.
- Fix the rack by turning on screws A.

2.2.2. Checking the drum-lock

- Loosen screws A (Fig. III-6) of rack 271 a few turns and push the rack to the right as far as possible.
- Check that locking bracket 246 (Fig. III-7) comes out symmetrically when the lower drum is turned in and out by hand.
- If necessary, the symmetry can be adjusted by bending bracket 245.
- Readjust the rack as described under 2.2.1.

2.2.3. Checking idler wheel 158

- Press the playback key.
- The distance between idler wheel 158 and flywheel 224 must be $1 \pm 0,5$ mm (Fig. III-8).
- This distance is adjustable with excentrical screw A.

2.2.4. Checking the cassette release

- The distance between the pin of the cassette release and the lay-on point of the cassette must be $11,5+0,5$ mm centre-to-centre (Fig. III-9).
- This distance is adjustable by loosening screw 17 a few turns and turn bracket 263 with respect to bracket 264, after which screw 17 is turned on again.

2.2.5. Checking the eject-knob locking

- Close the cassette holder.
- Now, both the eject button and the playback key can be pressed.
- When the playback key is pressed, the eject button must be blocked.
- If this is not so, the adjusting lug of bracket 545 must be bent.
- Check the distance between bracket 544 and pressure roller lever 239 as shown in Fig. III-10.
- Adjustments can be made by relocating bracket 544 after loosening screws 14 a few turns.

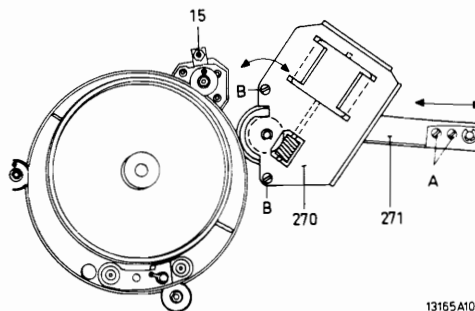

Fig. III-6

13165A10

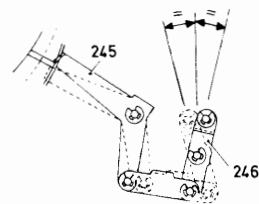

Fig. III-7

11859A7

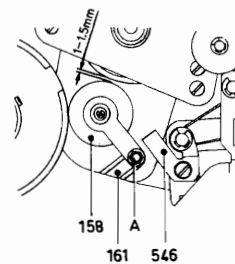

Fig. III-8

11860A7

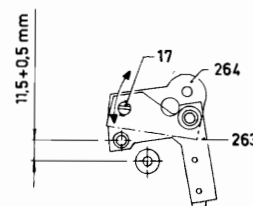

Fig. III-9

11862A7

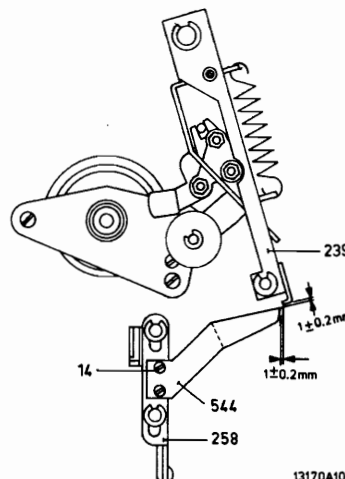

Fig. III-10

13170A10

2.2.6. Checking reel-disc brake S1

- Push in by hand the armature of S1.
- The distance between bracket 549 and the stop of bracket 202 must be $0,5 \pm 0,2$ mm.
- Adjustments can be made by relocating S1 in the direction of the arrow (Fig. III-11), after loosening screws 14 a few turns.

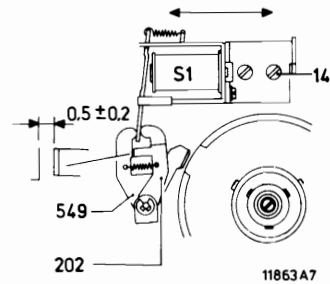

Fig. III-11

2.2.7. Checking electromagnet S6

- Check the armature stroke of electromagnet S6. Distance D must be $3+1$ mm (Fig. III-12).
- Adjustments can be made by bending stop plate A.
- Press the recording and playback keys.
- Check the release reliability by pressing on the armature of S6.
- Adjustments can be made by adjusting screw B as follows:
 - . Press the recording and playback keys.
 - . Push down the armature of S6 by hand.
 - . Adjust screw B so that the recording and playback keys are just released.
 - . Turn screw B clockwise another 180° and secure it with nut C.
 - . Thread-in the apparatus and take out the mains plug from the wall-socket.
 - . Push down the armature of S6 by hand.
 - . Check that none of the push-buttons are locked when they are fully pressed.
 - . If so, turn screw B clockwise another 180° .

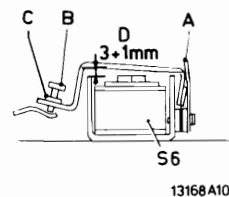

Fig. III-12

2.2.8. Check that there is a play of $0,5 - 0,2$ mm between chassis and adjusting screw 15 (Fig. III-6). If necessary, screw 15 has to be readjusted.

2.2.9. Check the stop force of the lower drum in threaded-in condition. It must be 1 kg and is measured at pin N (Fig. III-17) in threaded-in condition.

2.2.10. Checking the distance capstan-pressure roller

If the apparatus is switched-on by the electronic clock (start push-button and recording push-button are both pressed then) the distance between capstan and pressure-roller must be $< 0,3$ mm during the threading-in procedure (see Fig. III-12a).

When the start push-button is pressed with the set threaded-in, the distance between plate 554 and bracket 228 must be $> 0,5$ mm.

This can be adjusted by shifting plate 554 with respect to bracket 239 after loosening screw 15 a few turns.

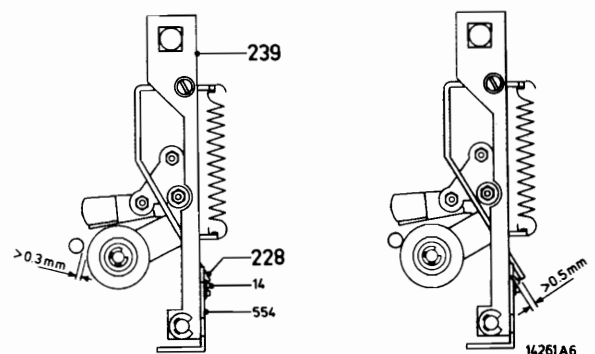

Fig. III-12a

2.3. SWITCHES

2.3.1. SK9

- Switch-on the set and slowly press the fast-wind key.
- SK9 must change over just before idler wheel 158 jumps to fast-wind position.
- Adjustments can be made by relocating mounting bracket 225 of SK9 after loosening screws 14 a few turns (Fig. III-13).

2.3.2. SK10

- Switch on the set and slowly press the rewind key.
- SK-10 must change over just before idler wheel 15R jumps to rewind position.
- Adjustments can be made by relocating mounting bracket 225 of SK10 after loosening screws 14 a few turns (Fig. III-13).

2.3.3. SK12

- Check that SK12 changes over during the threading-out procedure when spring A is tensioned (Fig. III-14).
- If necessary, mounting bracket 272 of SK12 must be relocated after loosening screw 14 a few turns.

2.3.4. SK13

- Check that SK13 during the threading-in procedure changes over when spring A (Fig. III-14) is tensioned.
- If necessary, the tensioning ring on switch-pin B has to be relocated.

2.3.5. SK15

- Switch-on the set.
- Within the 1 mm pre-travel of the eject key (Fig. III-10) SK15 must be closed.
- Adjustments can be made by bending the mounting bracket of SK15.

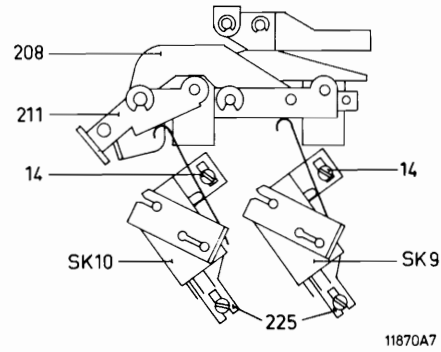

Fig. III-13

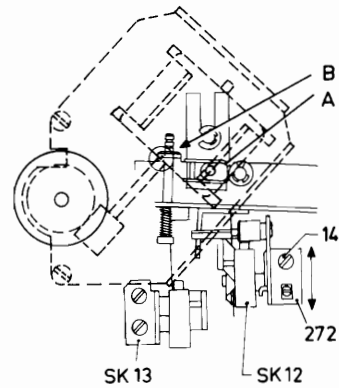

Fig. III-14

2.4. TAPE PATH ADJUSTMENTS

General

For adjusting the tape path the following tools are required:

- Test cassette with recesses 4822 397 60045
- Test cassette with pre-modulated tape 4822 397 60046
- Drum level 4822 395 80131. This level is used when the apparatus is placed to its reference position.
- Level 4822 395 50128. For checking the perpendicular adjustments.
- Level 4822 395 80083. For checking the pressure roller and idler wheel adjustments.
- Lever 4822 395 80084. For adjusting the idler wheel.
- Bending pipe 4822 395 80151. For adjusting the two cassette roller spindles.
- Bending pipe 4822 395 90097. For adjusting the reel disc spindle bearing.
- Gauge 4822 395 80077. For adjusting the height of the reel discs.
- Mirror with lighting lamp 4822 395 30062. Type SCP62 Codenumber lighting lamp 4822 134 40324.
- Square 4822 395 80082. For adjusting the audio/sync. head. The angle of this square is $90^{\circ}45'$.
- Spring pressure gauge 0-35 g 4822 395 80029
- Spring pressure gauge 10-100 g 5322 395 84011
- Spring pressure gauge 300-3000 g 5322 395 84009
- Allen key 2 mm 4822 395 50084
- Cleaning set 4822 389 20014

Important:

- All tape guide components have been carefully adjusted and secured. If faults in the tape path occur the possible cause must be determined first. This to prevent that proper adjustments have to be readjusted unnecessarily.
- The drum ruler with the cams O, P and R (Fig. III-15) has been carefully adjusted in the factory. Outside the factory, this ruler can be neither adjusted nor checked. If it turns out that after repeated tape path adjustments the apparatus does not work properly (compatibility), the lower drum must be exchanged. This is also true when the position of the ruler clearly deviates from the wear pattern on the lower drum or when the locking point of the mounting screws of the ruler is broken.
- Before checking or adjusting the tape path, all metal parts that come into touch with the tape have to be properly cleaned first (see the instructions of use of the apparatus).
- All adjustments must be carried out step by step in the sequence described.

2.4.1. Reference position of the apparatus

- Place the set on a stable, flat background.
- Switch-on the set and take out the mains plug from the wall-socket.
- Remove the cover plate and the cassette holder.
- Remove head disc 183.
- Place drum level 4822 395 80131 on the lower drum. See to it that the central pin of this level fits in the spindle bearing of the head disc and the outer pin in the corresponding hole of the lower drum. It is recommended to clean the tangent planes of level and lower drum first.
- Place the reel disc height adjustment gauge 4822 395 80077 into the apparatus.
- Level out the apparatus, using the level mounted on this gauge.
- With the drum level, check that the lower drum is in the right position. If not, it must be adjusted by adding or taking off rings 38, 40 and 43 underneath the drum guide rollers.
- If the position of the lower drum is correct (air bubble of the drum level exactly in the centre of the circle), then this is the reference position for other adjustments.

2.4.2. Perpendicular adjustments

The following parts must be adjusted perpendicularly. This can be checked with level 4822 395 50128:

a. Cassette roller spindles A and K (see Fig. III-17)

If necessary, these spindles can be adjusted with bending pipe 4822 395 80151. This pipe has a hole on either end. The hole with the smaller diameter is used for the two spindles.

The pipe must be slid over the spindles as far as shown in Fig. III-16.

b. Reel disc spindle bearing

To check the adjustment of this bearing, reel discs 150 and 159 must be demounted first. (The composition of ring package 151 must not be changed as otherwise the height adjustment of the lower reel disc is lost.)

If necessary, this bearing can be bent to the correct position, using bending pipe 4822 395 90097. This pipe has a hole on either end. The hole with the smaller diameter is used for this bearing.

c. Capstan G (Fig. III-17)

Adjustments can be made with screw H. Locking screw I must first be loosened a few turns and, after the adjustment, must be turned on again.

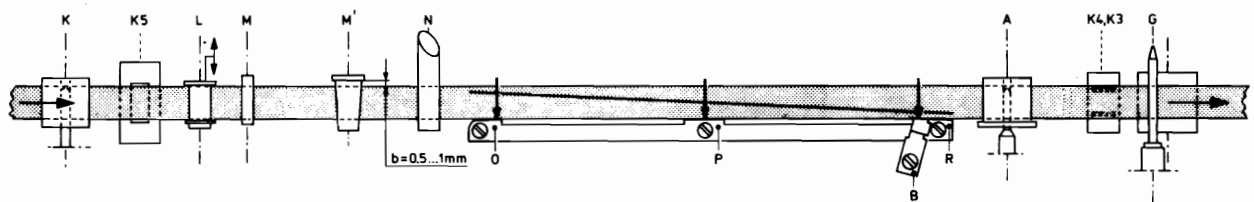

Fig. III-15

11858C7

2.4.3. Idler wheel 158

- Switch-on the set and press the rewind key.
- Place level 4822 395 80083 on the idler wheel.
- Check that the idler wheel has been levelled. The air bubble must be within the outer adjustment ring (this ring corresponds with a deviation of $\pm 7'$ with respect to the reference plane).
- Using lever 4822 395 80084 the idler wheel can be adjusted (see Fig. III-18).

Remarks:

- For this adjustment, the reel disc height gauge has to be removed from the apparatus.
- It is recommendable to slightly turn the level a couple of times during this check. This to make certain that unevennesses on idler wheel or measuring plane of the level do not influence the measuring results.

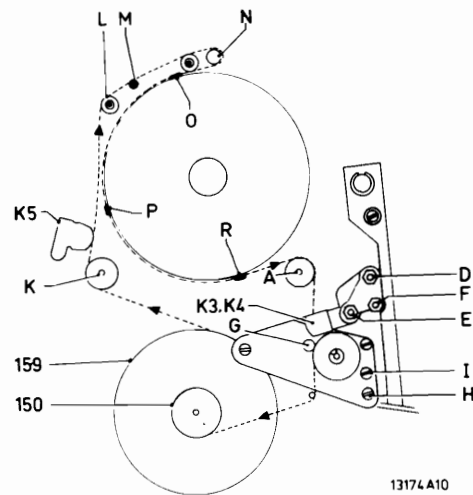

Fig. III-17

2.4.4. Pressure roller 227

- Switch-on the set and press the recording key.
- Open SK11 after 3 to 5 secs.
- Place level 4822 395 80083 on the pressure roller.
- Check the horizontal position of the pressure roller in East/West direction.
- The air bubble of the level in East/West direction must be within the outer adjustment ring, see Fig. III-19.
- Adjustments can be made with the adjusting screw 11.
- Let the apparatus run for 3 to 5 seconds by closing SK11.
- Check the position of the pressure roller again and, if necessary, repeat the adjustment described above.

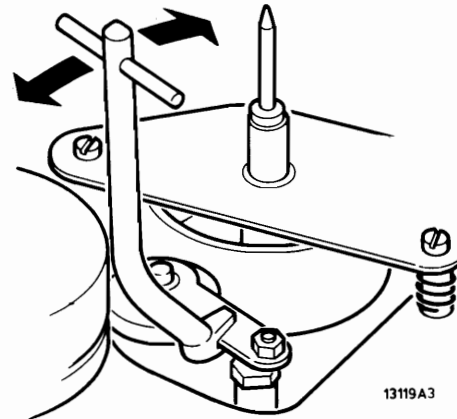

Fig. III-18

2.4.5. Audio/sync. head

- Switch-on the set and press the playback key.
- Place square 4822 395 80082 on the ground plane of the reel disc height gauge.
- Check that the face of the audio/sync. head is parallel to the measuring side of the square.
- Adjustments can be made by turning nut E in or out (see Fig. III-17).
- Check that the audio head is on the same height as the marking on the square.
- Adjustments can be made by turning nut F in or out (see Fig. III-17).

Remark:

- The exact height adjustment of the audio/sync. head is effected during the dynamic tape path adjustment.

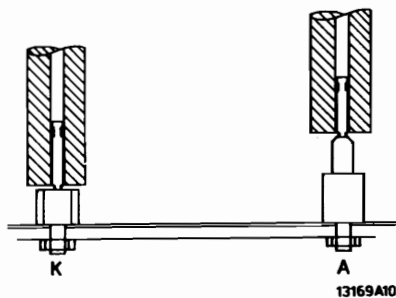

Fig. III-16

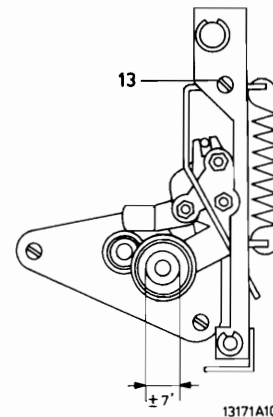

Fig. III-19

2.4.6. Insert-depth audio/sync. head

To carry out this adjustment, a jig must be made out of a machine-cut, strong piece of paper, according to Fig. III-20, for instance from a postcard.

- Press the playback key.
- Press the jig according to Fig. III-21 against the cassette roller spindles.
- Check that the audio/sync. head touches exactly the short side of the jig.
- Adjustments can be made by bending bracket 231 (Fig. III-21).

These adjustments completed, the drum level can be removed and the head disc mounted again.

2.4.7. Reel disc height (Fig. III-22)

a. Lower reel disc

- Check distance B, using reel disc height gauge 4822 395 80077 and the tail of a caliper gauge.
- Check distance B on the point diametrically opposite the first measuring point.
- These two distances must be equal, $7 \pm 0,1$ mm each.
- Adjustments can be made by adding or removing rings 151.
- Check the vertical play of the reel disc.
- This must be $0,15 \pm 0,1$ mm.
- Adjustments can be made by adding or removing rings 151.

Remark:

Under codenumber 4822 310 30414 a number of spacer rings 151 with varying diameters and thicknesses is supplied.

b. Upper reel disc

- Check distance A, using the reel disc height gauge and the tail of a caliper gauge.
- This must be $6 \pm 0,1$ mm.
- Adjustments can be made by adjusting pivot bearing 157. This adjustment completed, lock nut 25 must be turned on again.

2.4.8. Pressure roller 227

- Switch-on the set and press the playback key.
- Check the press-on force of the pressure roller, using a spring pressure gauge.
- This must be 1700 ± 300 g.
- If outside these tolerances, spring 240 must be exchanged.

These adjustments completed, the reel disc height gauge must be removed.

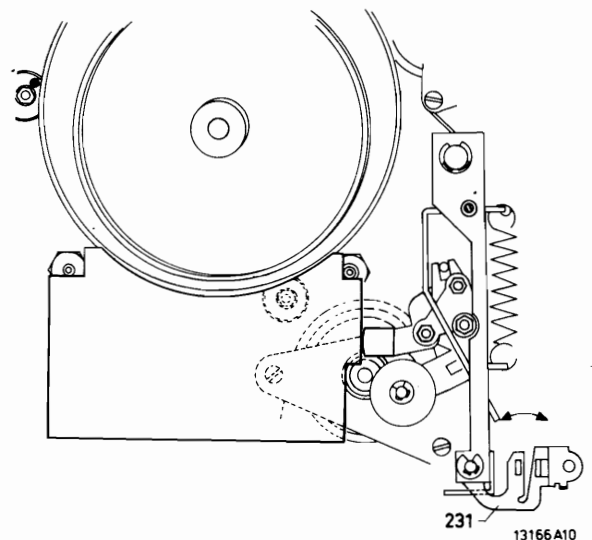

Fig. III-21

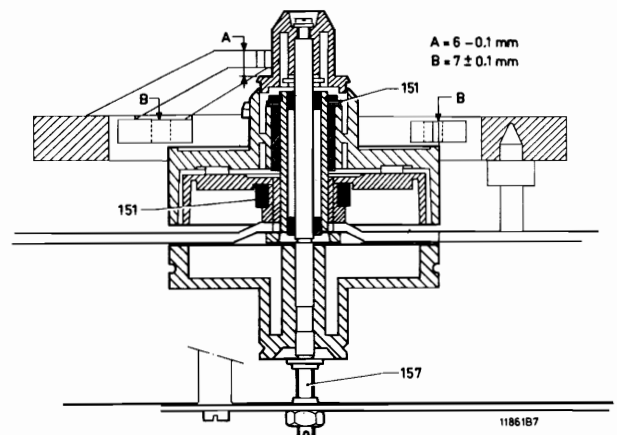

Fig. III-22

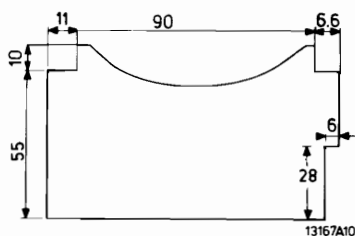

Fig. III-20

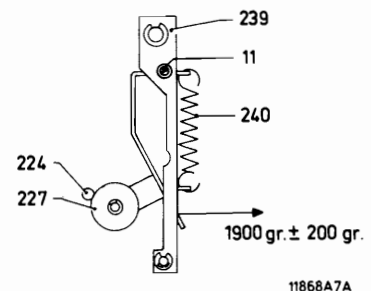

Fig. III-23

2.4.9. Frictions

Remarks:

- Frictions and pulling forces must be measured with a spring pressure gauge.
- With radius is meant the distance between the reel centre and the point where the force is measured (Fig. III-24).
- The force at a radius of 5,5 cms can be measured with a full reel and at a radius of 2 cms with an empty reel.
- For new cassettes the radius of the reel core is 1,8 cms. To be able to measure at a radius of 2 cms, some metres of tape must be wound on these reels.
- Using adhesive tape, a loop can be made at the end of the tape for cathing-in the spring pressure gauge.

a. Counter-friction torque upper reel disc

- Switch-on the set and press the rewind key.
- Lay on a single reel (upper reel from a cassette) with some metres of tape on it on the upper reel disc.
- The counter-friction torque must be 25 g, measured anti-clockwise at a radius of 2 cms.

b. Counter-friction torque lower reel disc

- Switch-on the set and press the playback key.
- Lay on a single reel without tape (lower reel from a cassette) on the lower reel disc.
- The rewind friction force must be 20 ± 5 g measured anti-clockwise at a radius of 2 cms.
- If the value measured is outside the given tolerances, reel disc 159 must be checked and, if necessary, exchanged.

c. Reel disc brake

- Switch-on the set.
- Lay on a single reel with tape (lower reel from a cassette) on the lower reel disc.
- The friction force must be 40 g, measured anti-clockwise at a radius of 5,5 cms.
- If this value is not measured, the electrical functioning of the reel disc brack must be checked.

Remark:

- When the set is switched-on and none of the tape transport keys is pressed, the apparatus will switch-off again after approx. 30 secs. The set must then be switched-on again.

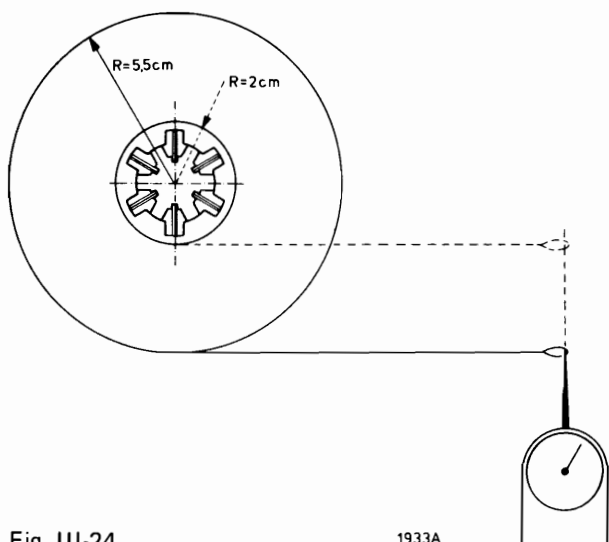

Fig. III-24

1933A

2.4.10. Dynamic tape-path adjustments

- Close solder bridge SP203 on the servo panel and open solder bridge SP204 (Fig. III-25).
- Demount the plastic tape guide B on the lower drum (Fig. III-15).
- Lay on test cassette with recesses 4822 397 60045.
- Switch-on the set and press the playback key.
- Check that tape guide M' is adjusted high enough. Distance b (Fig. III-15) must be 0,5...1 mm
- Tape guide L must be so adjusted that the tape just touches cam 0 of the drum ruler. Next, turn tape guide L another 135° clockwise.

Remark:

In Fig. III-15, arrows mark the points on cams O, P and R where it is checked whether the tape touches the cams correctly, using mirror 4822 395 30062.

- Using screw H, adjust the slope of capstan G so that the tape just touches cam R of the drum ruler. Next, turn screw H another 45° anti-clockwise.
- Turn on lock-screw I.
- Check again if the tape runs evenly and smoothly over the cams of the ruler.
- Remount the plastic tape guide B.

These adjustments completed, mount the cassette holder again.

2.4.11. Audio/sync. head (Fig. III-17)

a. Azimuth adjustment

- Insert test cassette with recesses 4822 397 60045.
- Connect the input of an oscilloscope to L11 on panel 51.
- Switch-on the set and press the playback key.
- Using nut D, adjust the azimuth of the audio/sync. head so that the voltage at L11 is maximum.

b. Height adjustment

- Connect the Y-A input of a double-beam oscilloscope to point B33 on panel 21.
- Connect the Y-B input to point L11 on panel 51.
- Switch-on the set and press the playback key.
- Using nut F, adjust the height of the audio/sync. head so that minimum interference occurs in both signals on the oscilloscope.
- Open solder bridge SP203 on the servo panel and close solder bridge SP204.
- Take off the test cassette with recesses and remount the cover plate.

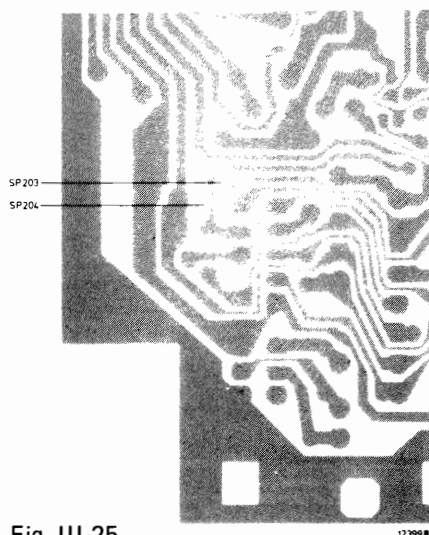
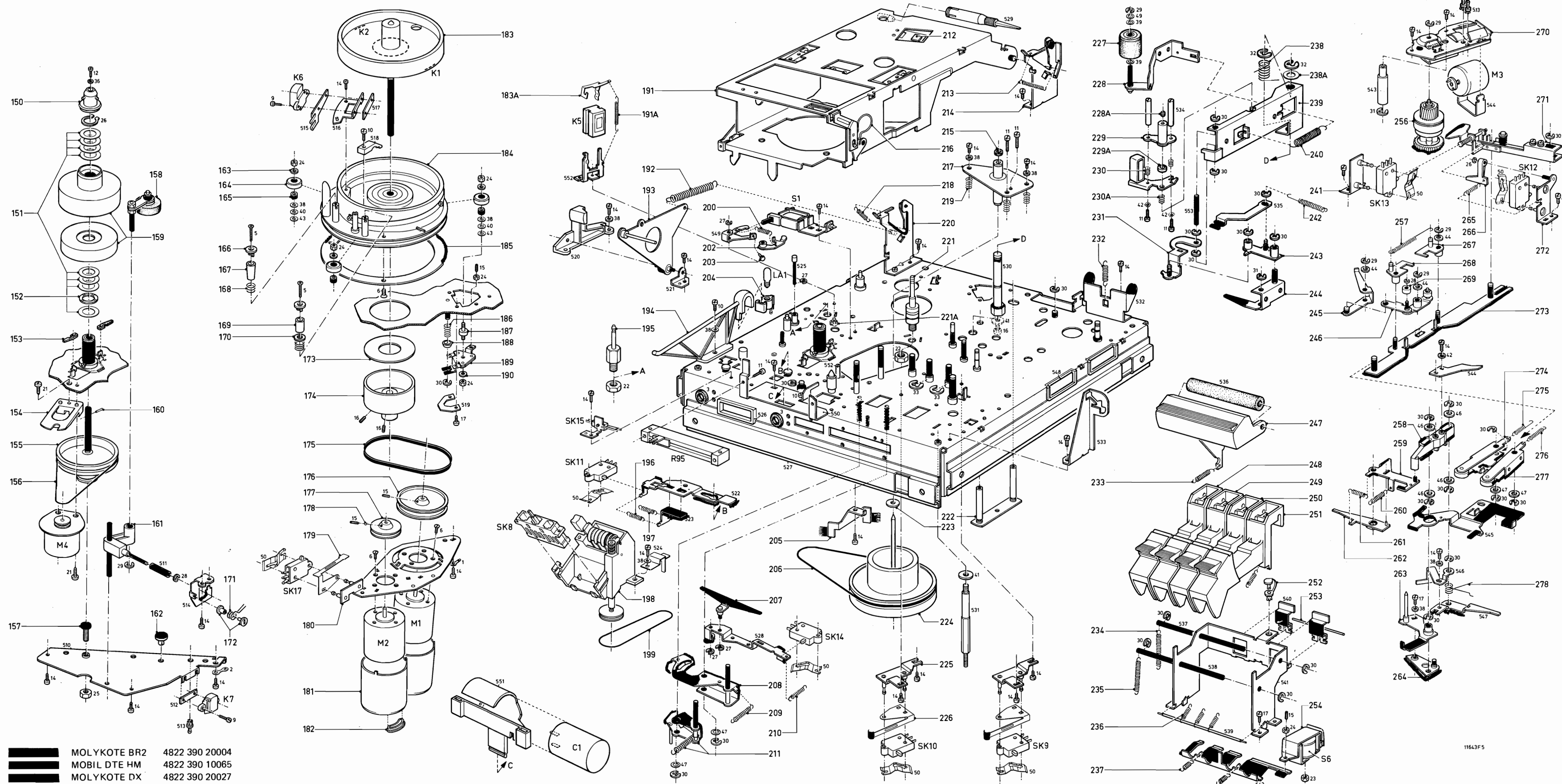





Fig. III-25

12399B12



	MOLYKOTE BR2	4822 390 20004
	MOBIL DTE HM	4822 390 10065
	MOLYKOTE DX	4822 390 20027
	TELLUS 27	4822 390 10022

11643F5

IV. CIRCUIT AND WIRING DIAGRAMS

Contents	Page
1. Measuring	IV-2
2. Explanation of the signs and symbols used in the diagrams	IV-3
3. Connecting data of the semi-conductors applied	IV-3
4. Circuit and wiring diagrams	
- Circuit diagram A (signal section)	IV-4
- Track sides of main PC-boards of the signal section	IV-5
- Circuit diagram B (servo section)	IV-6
- Track side of servo PC-board	IV-7
- Circuit diagram C (supply and control section)	IV-8
- Track side of supply PC-board	IV-9
- Circuit diagram D (electronic timer)	IV-10
- Track and parts side of timer PC-board	IV-11
- Survey of supply points	IV-12
- Wiring diagram	IV-13
	IV-14

1. MEASURING

Measuring the DC-currents and oscillograms shown in the circuit and PC-board diagrams.

General

- Unless otherwise indicated, all voltages were measured with respect to mass with a moving-coil meter with an R_i of 40.000 Ω/V .
- All oscillograms were measured with respect to mass with an oscillograph with an input impedance of 1 M Ω // 20 pF via an attenuation probe of 10 M Ω //10 pF.
- All voltages and oscillograms were measured at nominal mains voltage.

DC-voltages

Measuring the DC voltages:

Recording circuits

- . Insert dummy cassette, so that cassette switch SK17 is closed.
- N.B.: By cassette dummy is understood a cassette without reels.
- . Set to recording
- . No aerial signal supplied
- . Set channel selector to VHF

Playback circuits

- . No cassette in the recorder
- . Set to playback

Oscillograms

Measuring the oscillograms:

Recording circuits

- . Insert dummy cassette
- . Set to recording
- . Supply colour bar pattern from generator PM 5509 to aerial input.
- Carrier frequency of signal supplied in the VHF range
- Output voltage of pattern generator 10 mV
- . Burst control on pattern generator to nominal
- . Tune the recorder to the signal supplied.

Playback circuits

- . Playback of a colour bar pattern from a PM 5509 previously recorded on tape.
- . Tracking control optimally adjusted.

MEASURING INSTRUMENTS

Oscilloscope	PM 3226
* Pattern generator	PM 5509
Pattern generator	PM 5501
Millivoltmeter (AC)	PM 2454B
Standard Multimeter	PM 2503
Digital Multimeter	PM 2513A
Universal Digital Multimeter	PM 2522

* Note:

Fluctuation in colour saturation during reproduction of a colour signal recorded with a PM 5509.

Explanation: The sync signal supplied by the PM 5509 does not come up to the transmitter standard. (The line frequency has not been quartz controlled.) The consequence might be that the line pulses in the video tracks no longer lie opposite each other. (See Fig. II-1.)

As a result, amplitude and phase fluctuations in the chrominance signal might occur during reproduction. On the picture screen colour saturation fluctuations and colour faults will be visible.

2. EXPLANATION OF THE SIGNS AND SYMBOLS USED IN THE DIAGRAMS

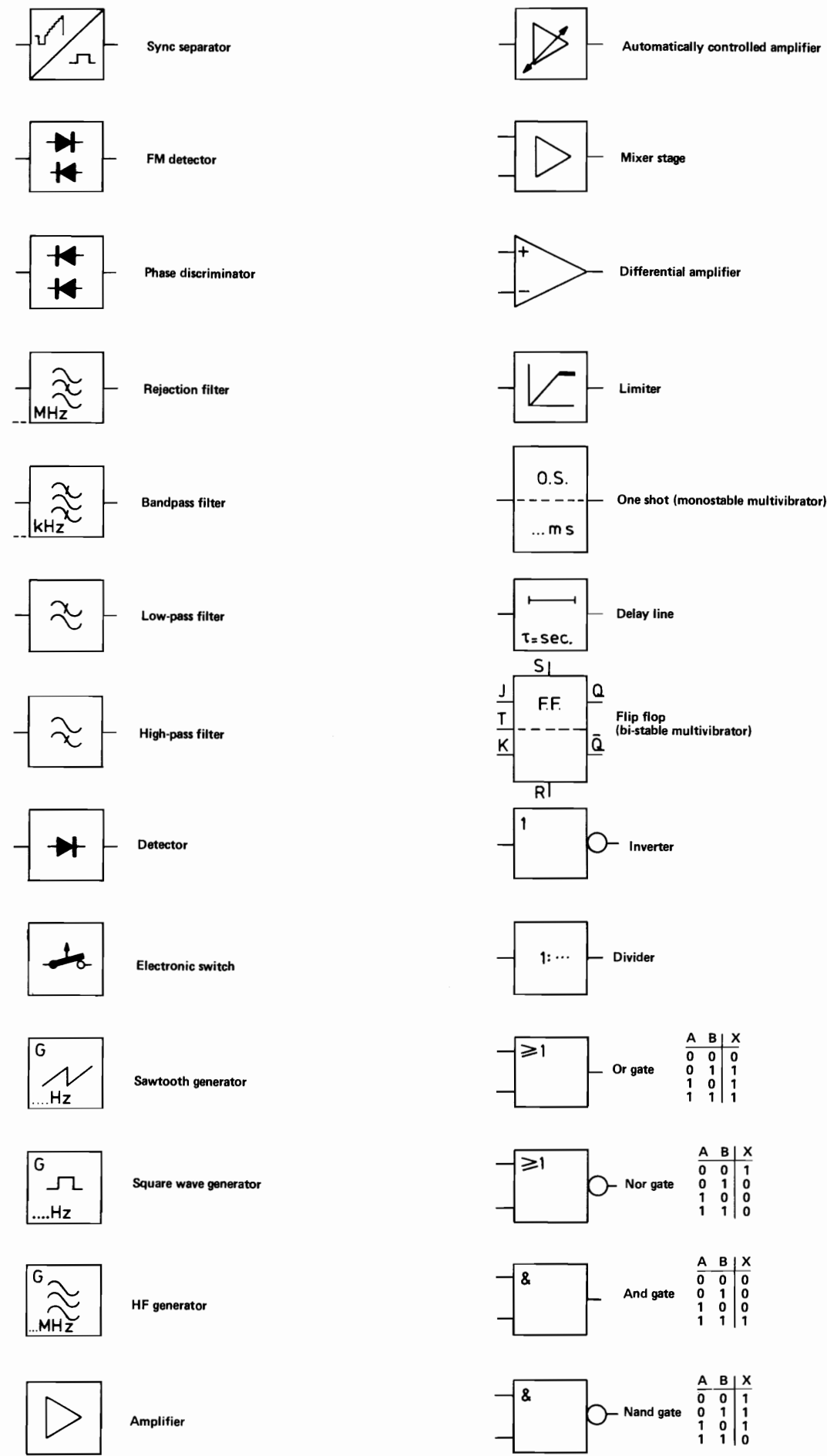

10104C12A

3. CONNECTING DATA OF THE SEMI-CONDUCTORS APPLIED

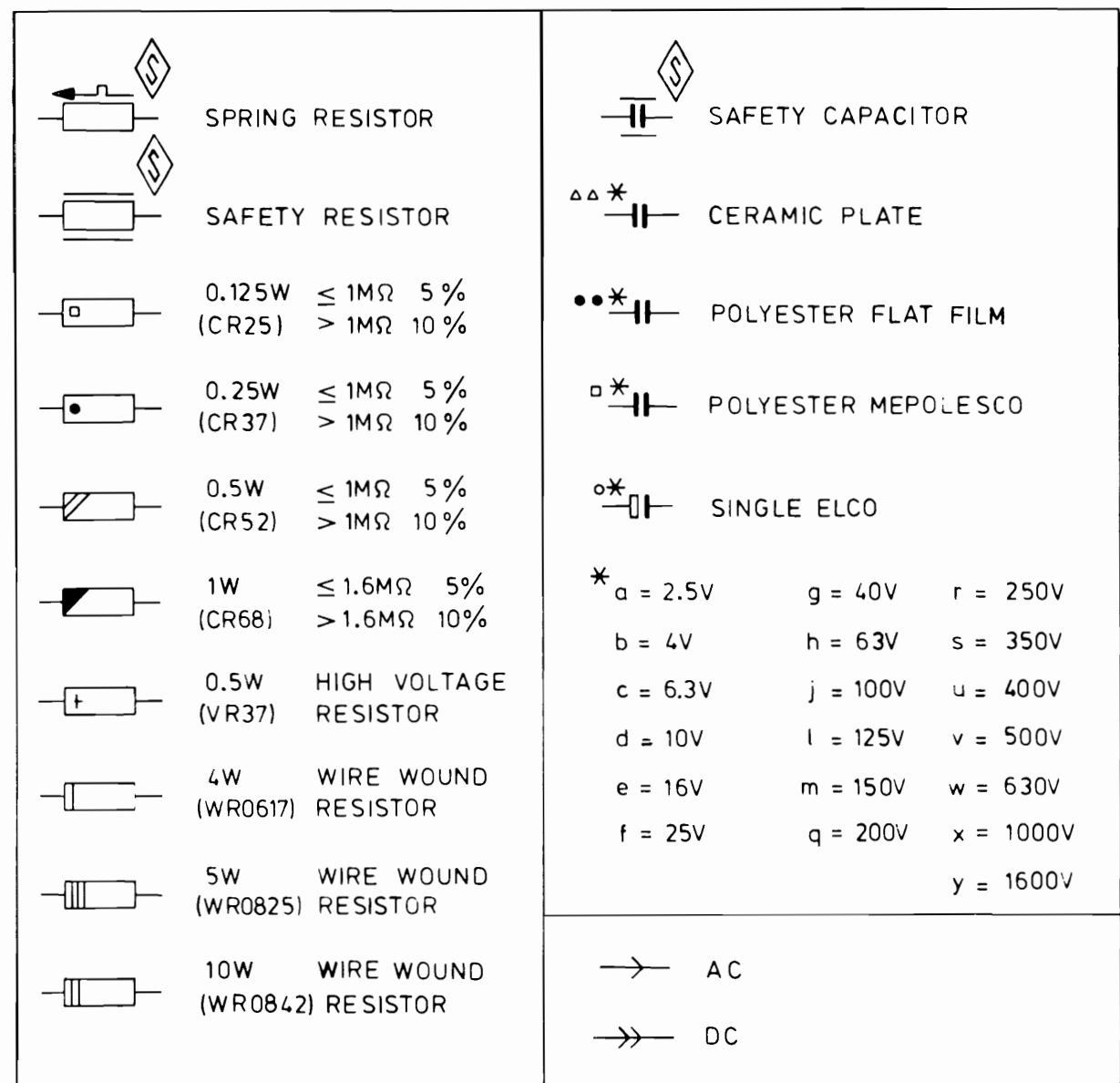

8520B 2

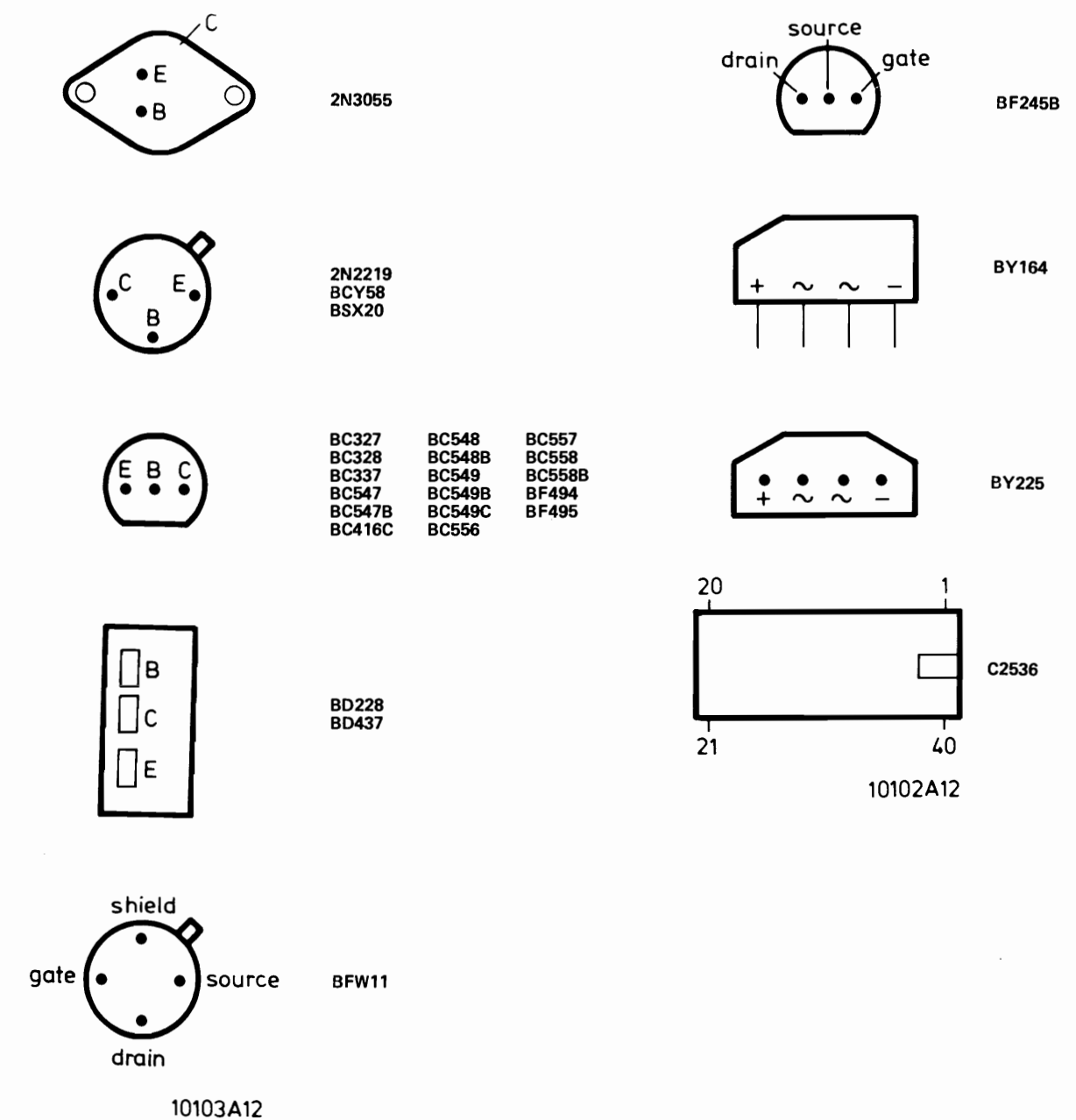

CIRCUIT DIAGRAM A (signal section N1700 PAL)

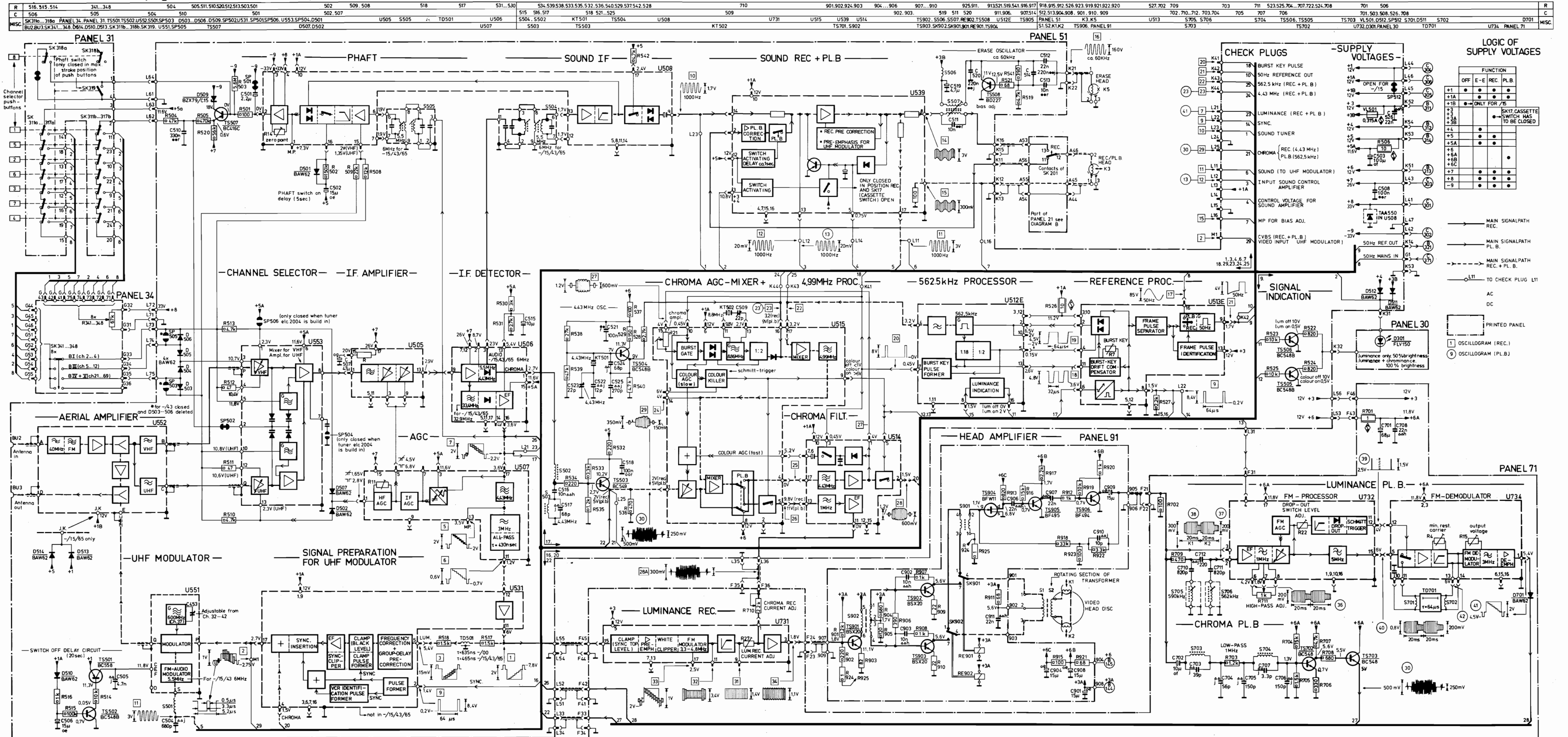

CIRCUIT DIAGRAM A (signal section N1700/00PAL) adapted to factorycode WD-04

R	516, 515, 514	341, 348	504	505, 511	520, 544	503, 501	508	502, 543	518	517	531, 530	534, 539, 538, 533, 535, 532, 536, 540, 529, 537, 542, 528
C	506	505	504	510	501	502, 507		528	515, 516, 517	528	515, 516, 517	518, 521, 525
MISC	SK311a...318a	PANEL 34, PANEL 31, TS501, TS502, U552, SS01, SP503, D506	D509, SP502, U531, SP501, SP506, U553, SP504, D501	U505, S505	TD501	U506		U506	SS04, S502	KT501	TS504	U508
	BU2, BU3, SK341...348, D514, D510, D513, SK311b...318b, SK319, U551, SP505	TS507		U537, S508	SS03	TS503						

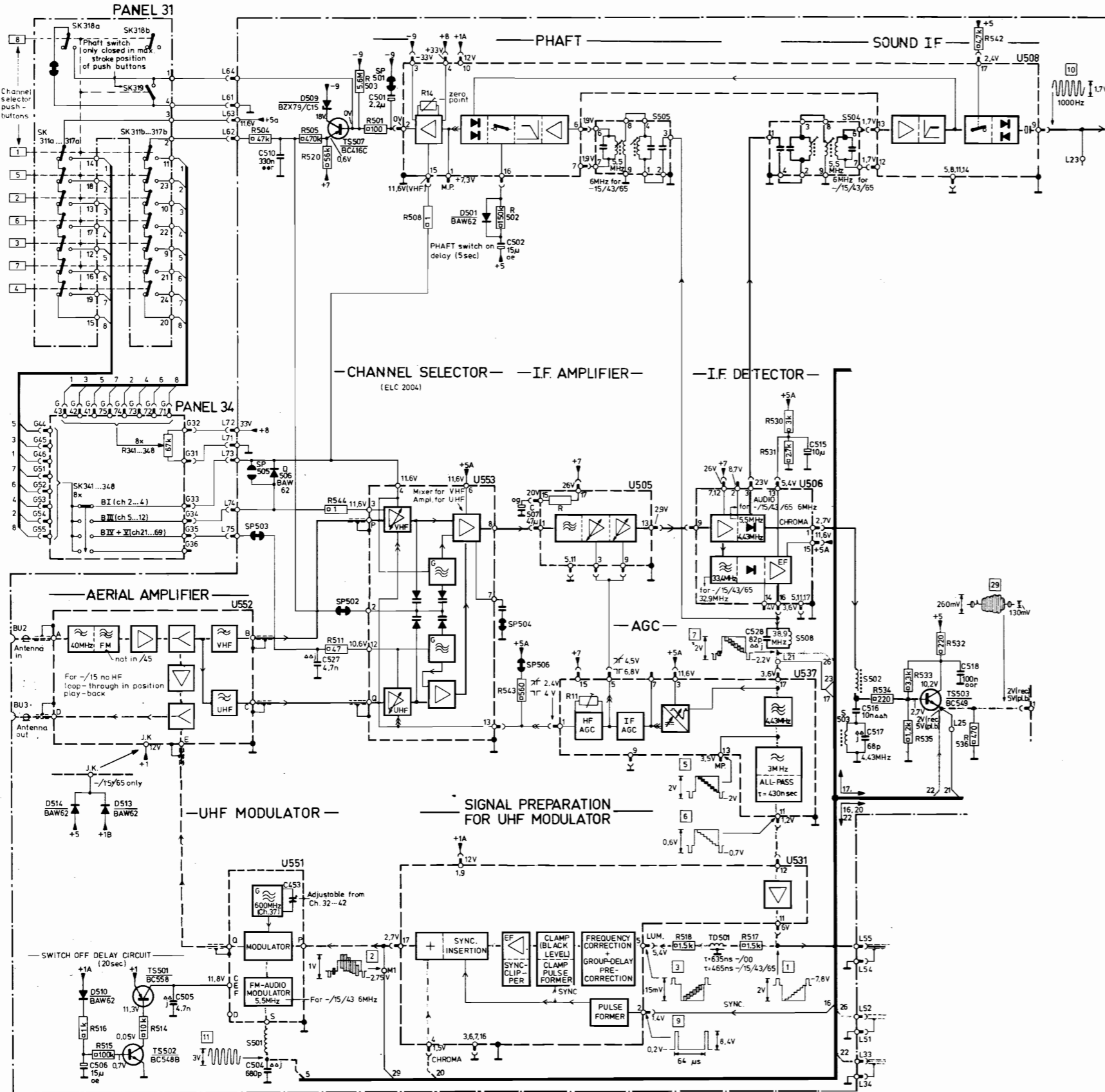

CIRCUIT DIAGRAM A (signal section N1700/15/43/45/65) adapted to factorycode WD-03

R	516, 515, 514	341, 348	504	505, 511, 510, 520, 512, 513, 503, 501	508	502
C	506	505	504	510	501	502, 507
MISC	SK311a...318a	PANEL 34, PANEL 31, TS501, TS502, U552, SS01, SP503, D503...D506, D509, SP502, U531, SP501, SP506, U553, SP504, D501	TS507		U505, S505	TD501
	BU2, BU3, SK341...348, D514, D510, D513, SK311b...318b, SK319, U551, SP505	TS507		U537, S508	SS03	TS503

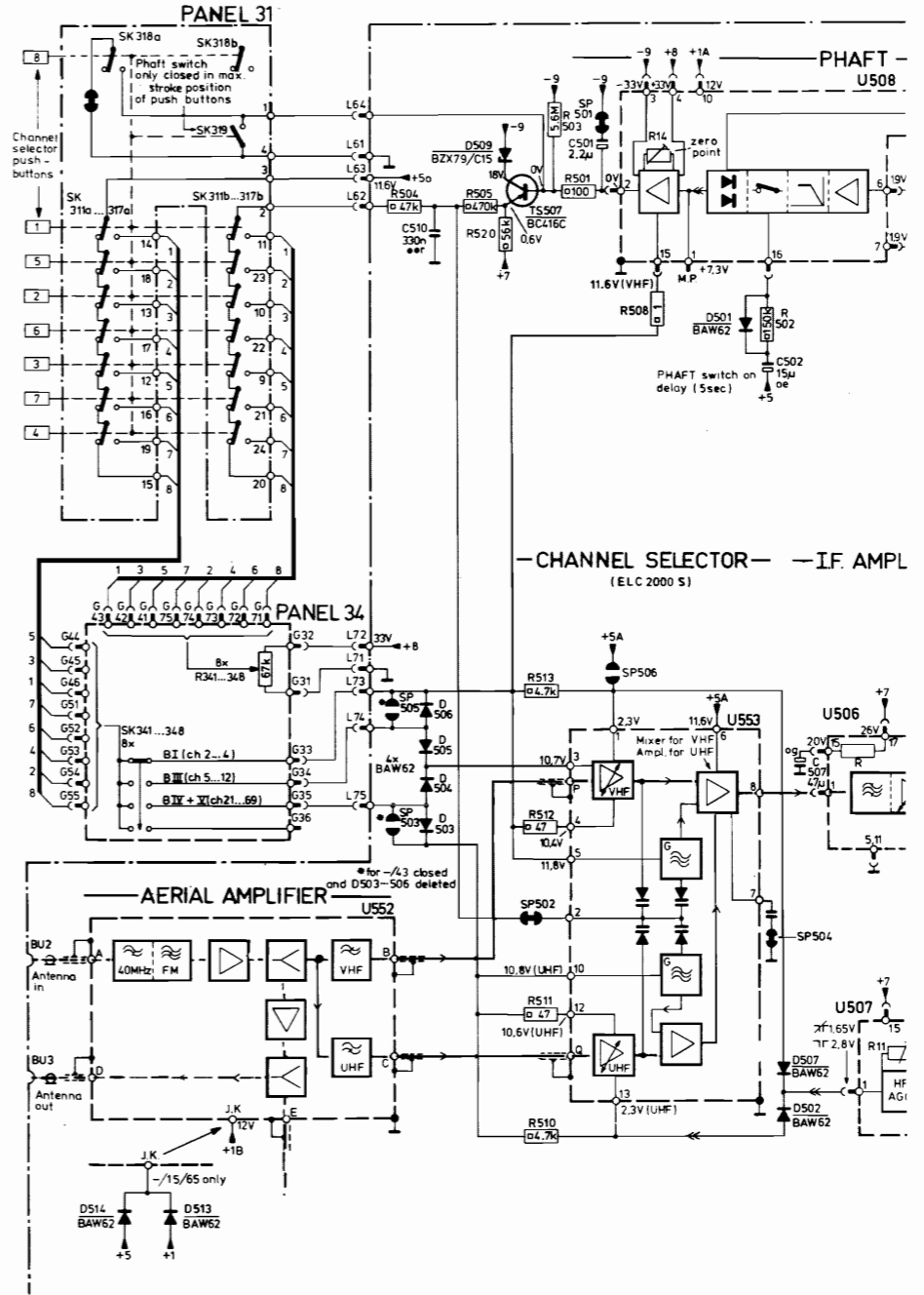

FOR THE REST OF THE DIAGRAM SEE CIRCUIT DIAGRAM A OF -/00 VERSION adapted to factorycode WD-04

PANEL 51 N1700/00 (adapted to factorycode WD 04)

IV-5-2, N1700

MISC	BU2	D506	U553,TS507	D509	S505,S508	D501	U508,TS504,U552,TS503,US31,S37,S05,S06,TS501,SS01-502,US61,TS501,504,BU3,TS502,S507,S06,KT501V,501,TS508,0560-512,KT502,TS506,U530,U516,512E,TS505,U515,514												
C			527,510	501	503,515,502,528	508	518	507	518,505,517	523,504,513,526,506,511,512,514,519,522,520,524,525,521	509								
R	503-505	506,544,543,501,511,520	530	506	531	502,532	508	542	533-536	517,518	541	540	514-516	537-539,526	529,519,521	523	525	522	524

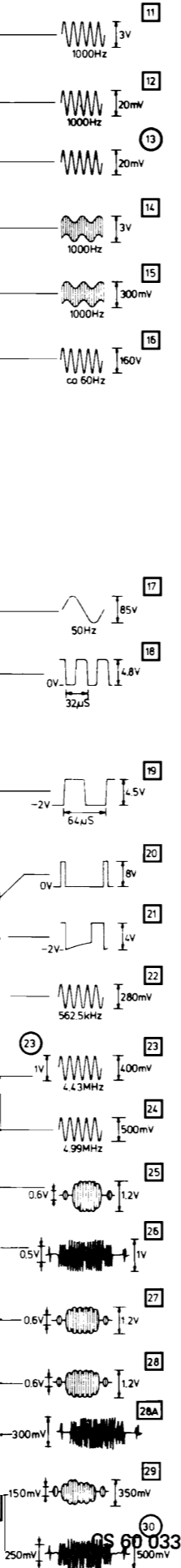
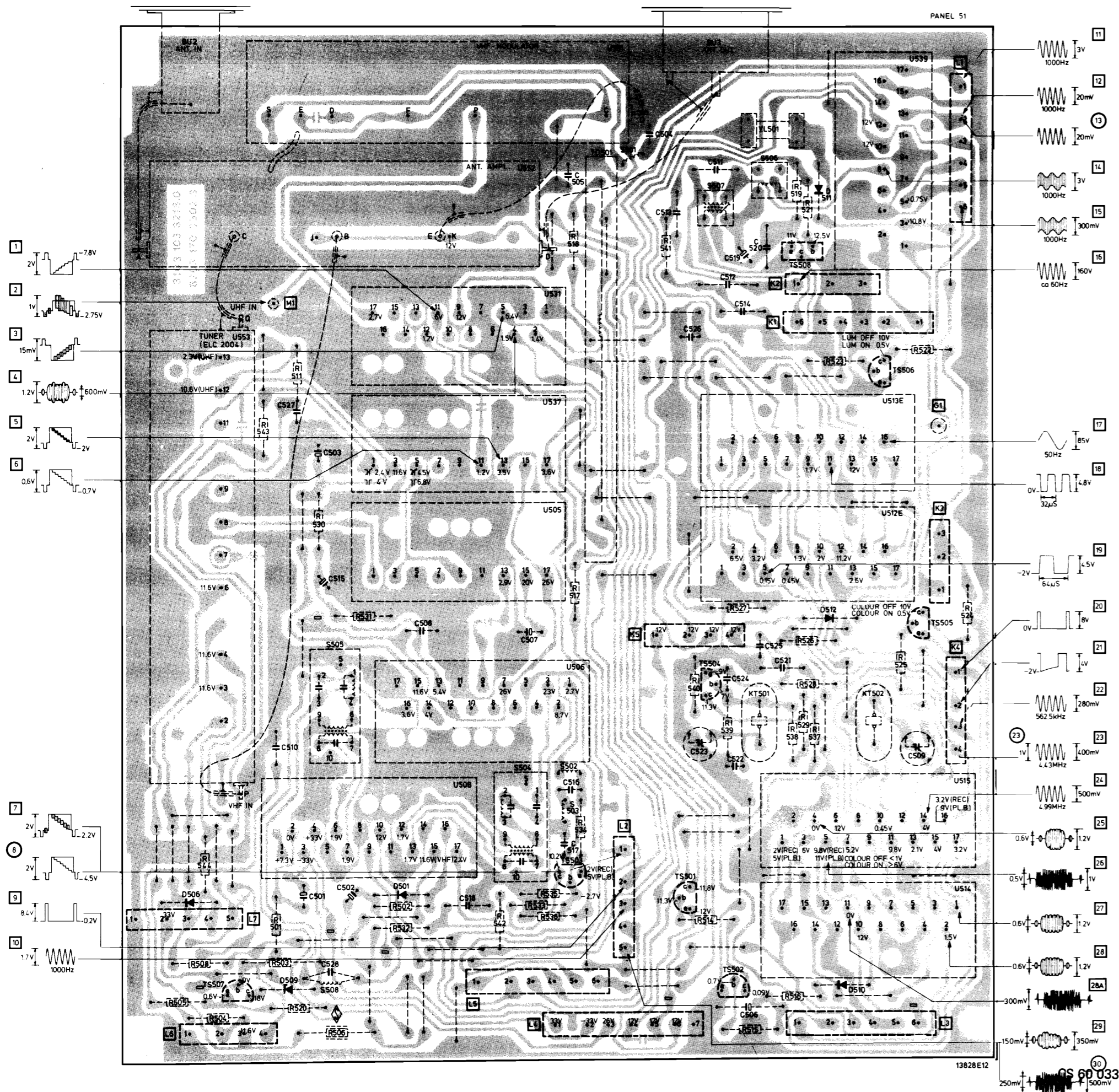

CIRCUIT DIAGRAM A (signal section N1702/00PAL)

R	516.515.514	341.348	504	505.511	520.544	503.501	508	502.543	518	517	531.530	534.539.538.533.535.532.536.540.529.537.542.528	710	901.902.924.903	904...906	907...910	925.911.527.913.521.519.541.916.917	918.915.912	923.919.921.922.920	702.709	703	711	523.525.704...707.722.524.708	701.506	R		
C	506	505	504	510	501	501	502.507	502.507	518	517	528	515.516.517	518.521.525	509	902.903	519.511.520	911.906	907.514	512.513.904.908.901.910.909	702.710...712.703.704	705	707	706	701.503.508.526.708	C		
MISC	SK310...318a	PANEL 34	PANEL 31	TS501	TS502	U552	U550	SP503	D506	SP502	U531	SP501	SP506	U553	SP504	D501	U505	U505	U505	U505	U505	U505	U505	U505	U505	U505	MISC

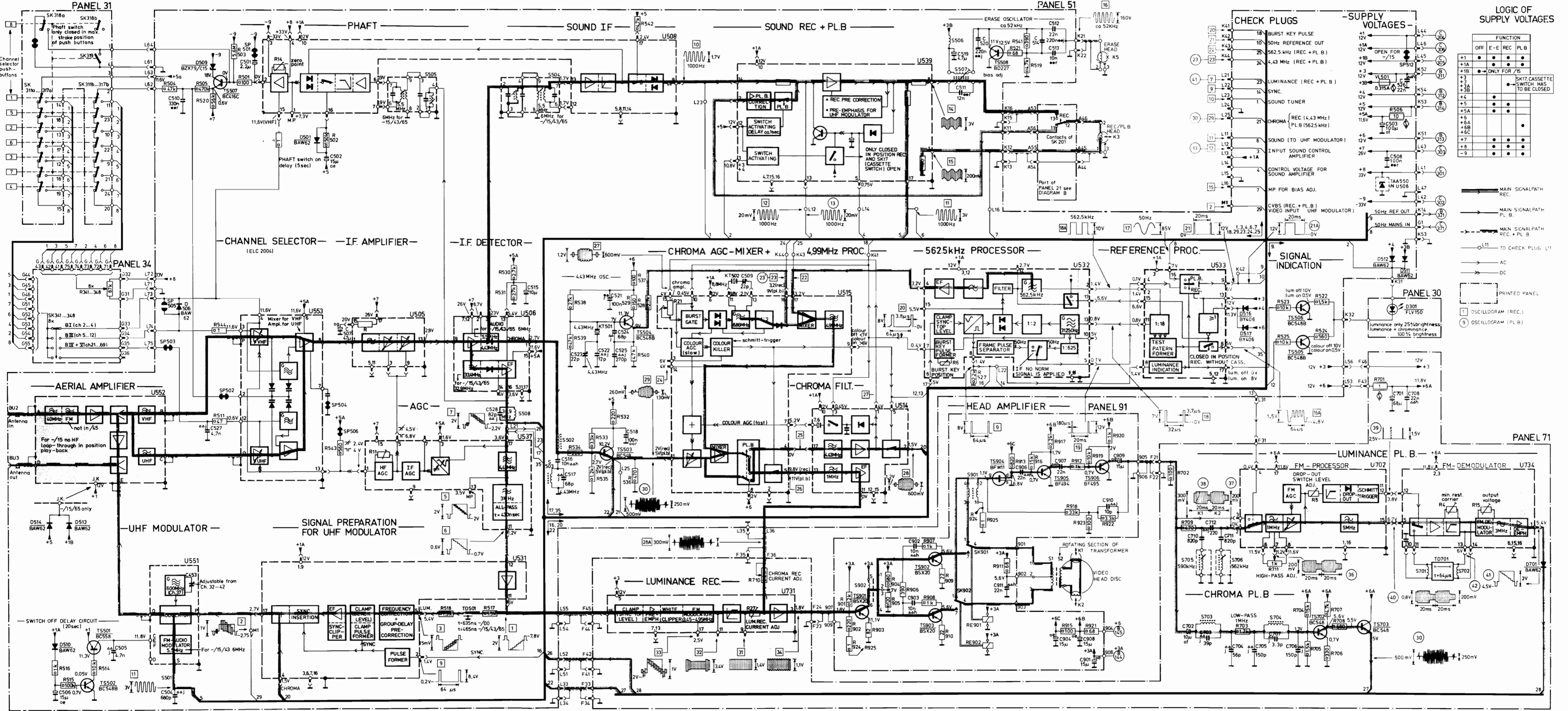

LOGIC OF SUPPLY VOLTAGES

FUNCTION	OFF	E-E	REC	PL.B
+1				
+1A				
+1B				
+1C				
+1D				
+1E				
+1F				
+1G				
+1H				
+1I				
+1J				
+1K				
+1L				
+1M				
+1N				
+1O				
+1P				
+1Q				
+1R				
+1S				
+1T				
+1U				
+1V				
+1W				
+1X				
+1Y				
+1Z				

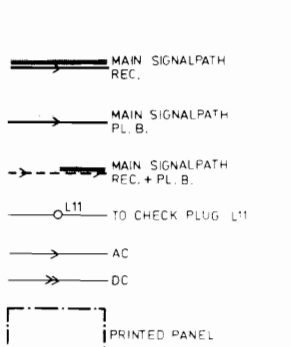

CIRCUIT DIAGRAM B

R	95	201	202			208, 207	205, 206	401, 402	R				
C		205, 204	206, 201				202, 203	401...406	407...410	C			
MISC.	K6, K4	S203	SK17	TS203	U236, U237	U219, U230	U228	D201, TS205	TS204, 201, 202	S201, 202	S401...406	M1, M2	MISC.

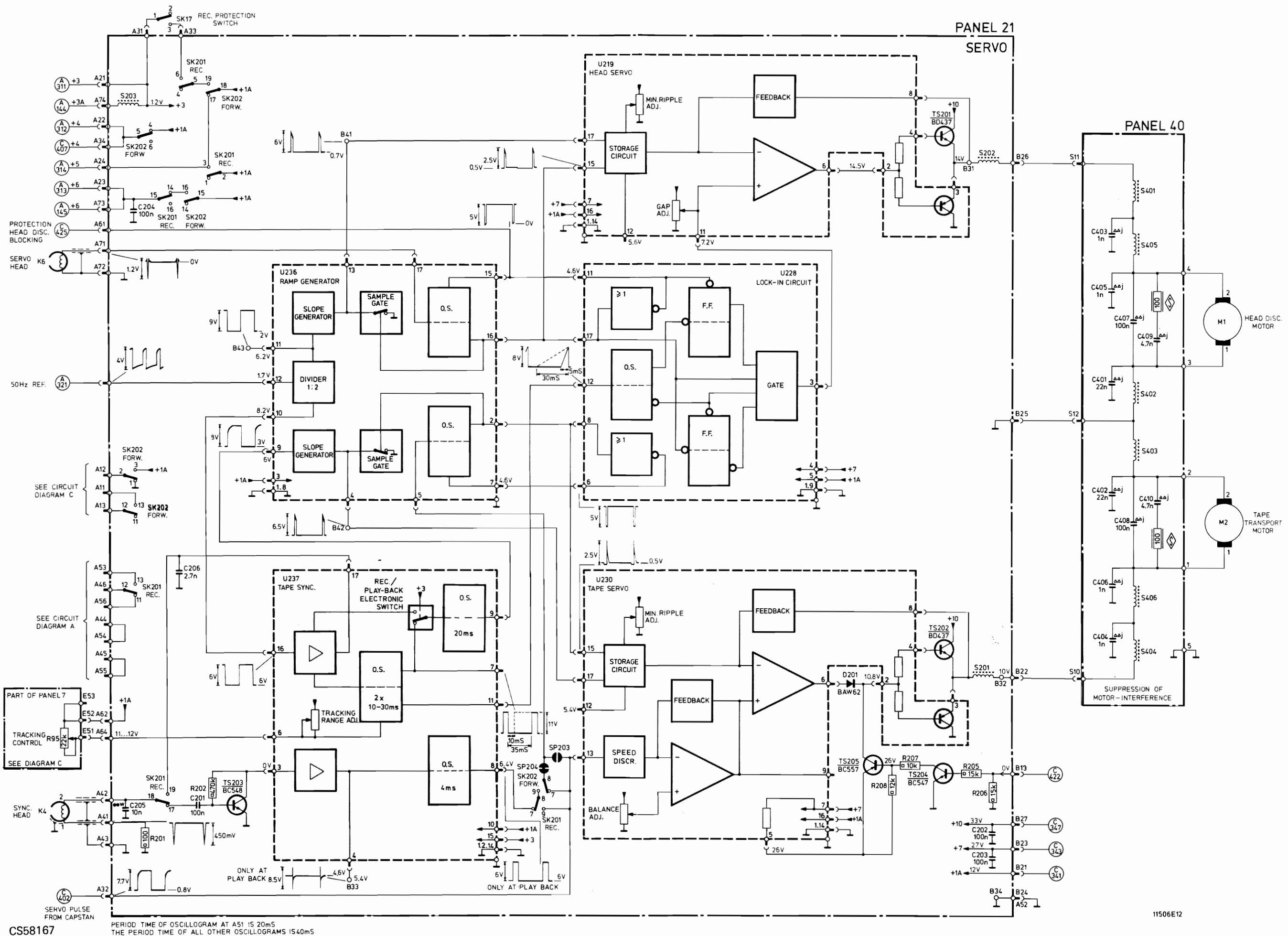

WIRING DIAGRAM B

R	C	TS	MISC
	203		
		201	U219
			S202
206			
207			
205	202		
208			
		205	S201
		204	D201
			U230
	204		
		202	
			S203
			U228
			U236
			U237
	206		
	205		
	202		
		203	
	201		
		201	
			SK201
			SK202

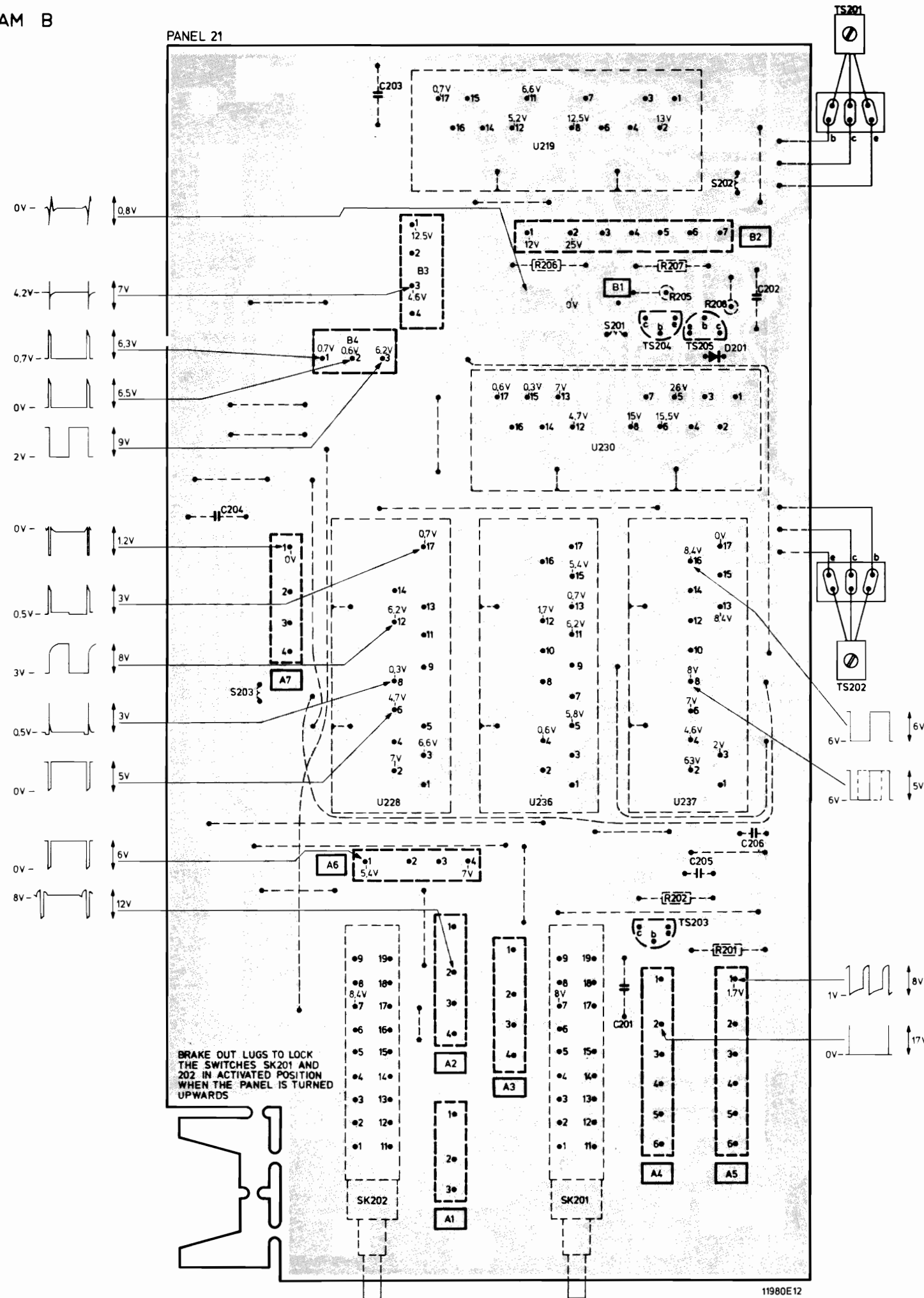

PANEL 40

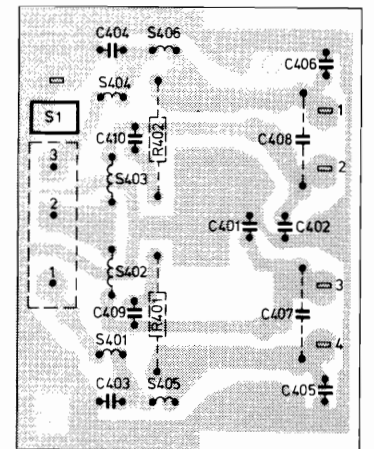

10 115 B7

MISC	R2	TS109...111, IC104	IC102,103	TS107,108	TS105	TS106,112, RE101, IC101	P1	TS113, P2...4	P5	P6	RE102, P7, VL102, P8	P9	M3, TS102...104, VL101, R1	TS101		
MISC	D123	D126,125,119,114,106,121		D116	D130,120	D128,111,113,129,118,124,104,115,110,122,112,117				D127		D102,101	D107...108	D105,103		
C	123,120	132,131	128...130,126,124,117,119	125,118,133,134,122,110	116,105		127	115			109	114,108	102	111,104,112,107,103		
R	147,140...142,152...155,127...133,135...138,151,123...125,148,164...166,121,158...160,156,134,126,143...146						157	122,161,105...108,113,139	150,101		112	163	149,109,114...120	162	111	102

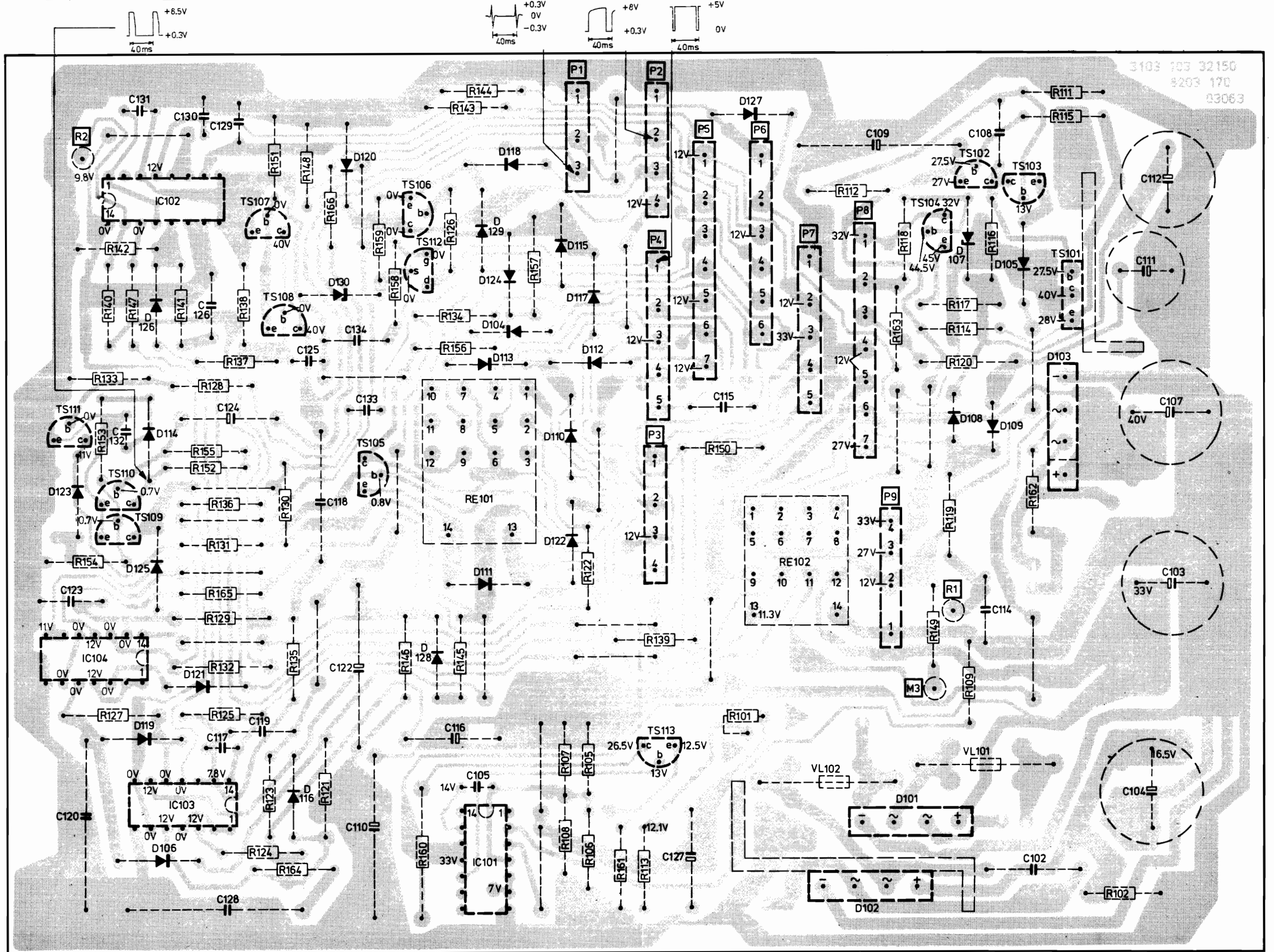
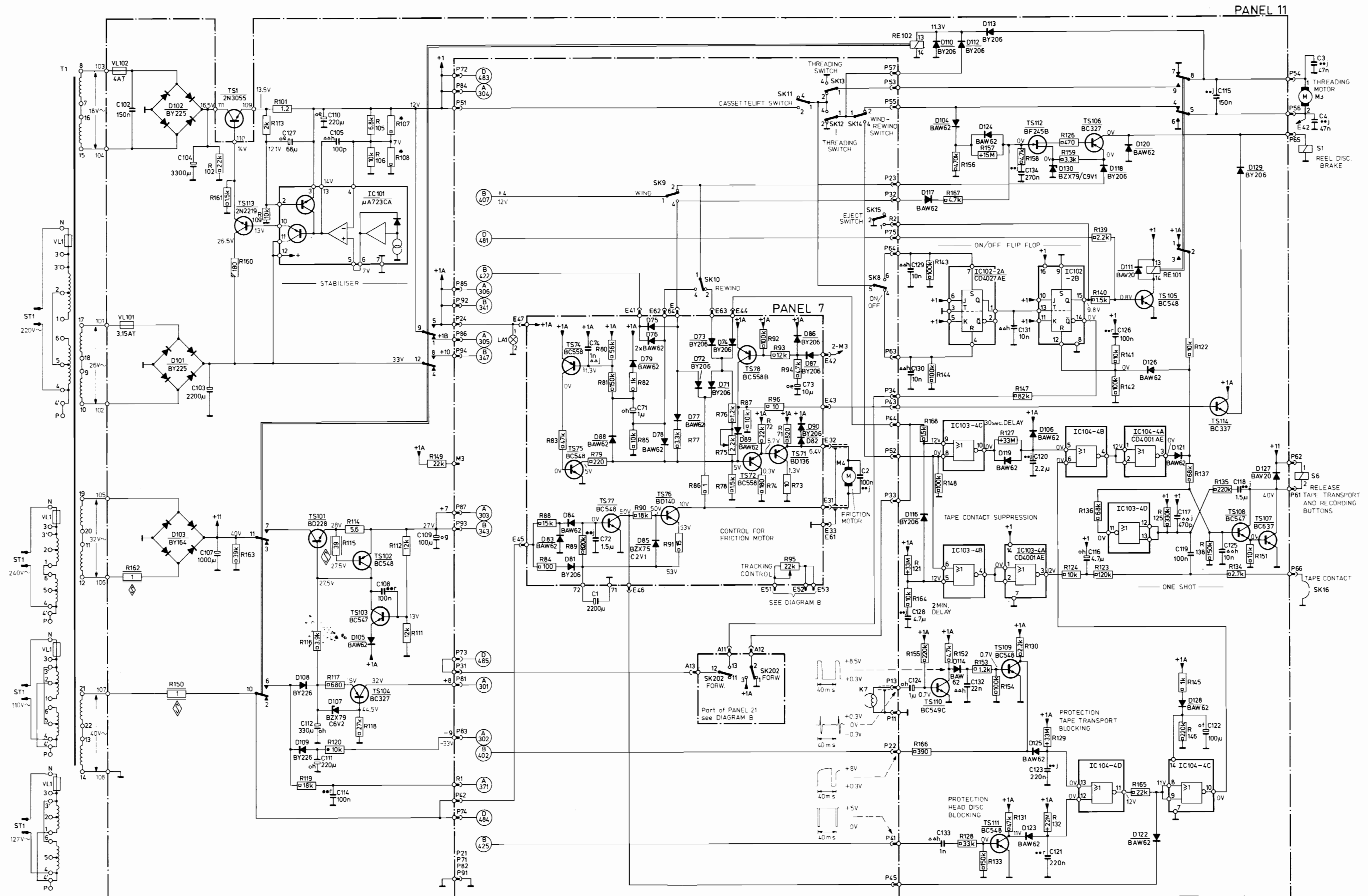

DIAGRAM C (ADAPTED TO FACTORYCODE WD02)

MISC	ST1, VL1, T1	VL102, 101	D102, 101	TS1, 113	IC101	LA1	TS74, 75	D88, 75, 76, SK9	D79, 78	D77, SK10, D71-74	TS78	SK11, D86, 87	SK12-14	SK15, 8	RE102	D117, 110, IC103	D112, 113, 124, 119	IC102	TS112, D106, 130	TS106	IC104	D118, 120, 111, 126	D121	RE101	D129, 127	M3, S1, S6	MISC.		
MISC			D103	TS101	TS103, D105, TS102, D108, 109	D107, TS104	D83, 84, 81	TS77	D85	TS76	SK202	TS72, D89	TS71, D82, 90	M4	K7	D116, TS110, D104, 114	TS111, 109, D123, 125	D122	D128	TS105	TS108	TS107, 114	SK16	MISC.					
C		102	104, 103, 107	127	110, 105, 108	112, 111, 114	109	74, 1, 72	71		73					129, 130, 128, 124, 133, 132	131, 134, 120, 123, 121	116	126				117, 119	122	115	125	118	3, 4	C
R71-96					109, 101, 113	114-120	105-108, 112, 111				82, 88, 84	89	83	79-82	85	90	91	77, 86	76, 75, 78, 87, 72, 74	92, 93, 96, 71, 73, 95, 94								R71-96	
R101-135		102																										R103-135	
R136-168		162	150	161, 160, 163			149																					R136-168	



(ADAPTED TO FACTORYCODE WD 02)

MISC	R2	TS109-111, IC104	IC102,103	TS107,108	TS105	TS106,112, RE101, IC101	P1	TS113,114, P2-4	P5	P6	RE102, P7, VL102, P8	P9	M3, TS102-104, VL101, R1	TS101			
MISC		D123	D126,125,119,114,106,121	D116	D130,120	D128,111,113	D118,124,104	D110,122,112,117,129		D127	D102,101	D107-108	D105,103				
C		121,123,120	132,131	128-130,126,124,117,119	125,118,133,134,122,110	116,105			127	115	109	114,108	102	111,104,112,107,103			
R		147,140-142,152-155,127-133,135-138,151,123-125,148,164-166,121,158-160,156,134,126,143-146							157,167,122,161,105-108,113,139,168	150,101		112	163	149,109,114-120	162	111	102

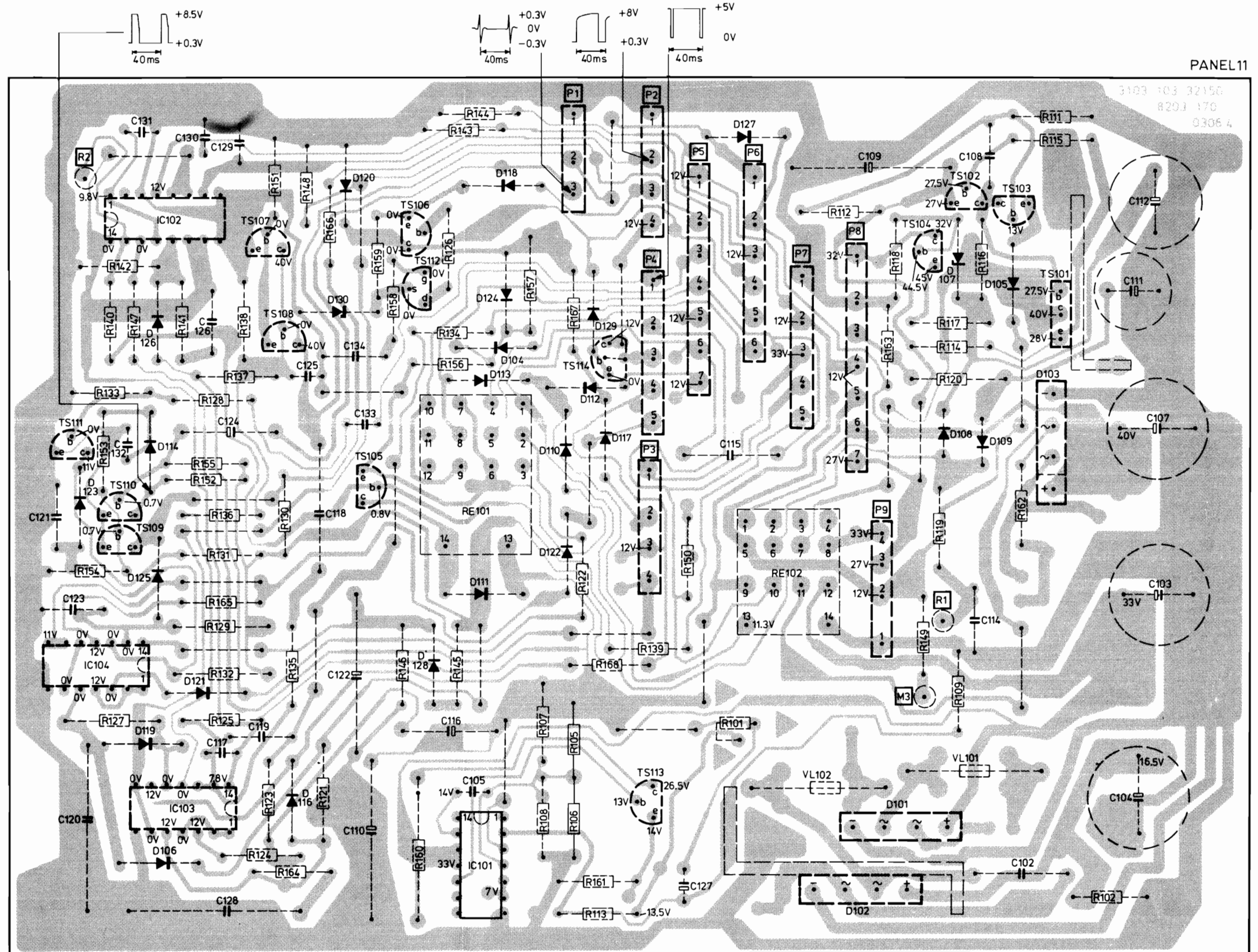

(ADAPTED TO FACTORYCODE WD09 FOR/00 AND WD08 FOR/15/43/45/65)

MISC	TS109-111, IC104, D132,106, IC102,103, D131	TS107,108	TS105	TS106,112, RE101, IC101	P1	TS113,114, P2-4	P5	P6	RE102, P7, VL102	P8	P9	M3, TS102-104, VL101, R1	TS101		
MISC	R2, D123	D126,125,119,114,106,121	D116	D130,120	D128,111,113	D118,124,104	D110,122,112,117,129	D127	D102,101	D107-108	D105,103,115				
C	121,123,120,135,132,131	128-130,126,124,117,119	125,118,133,134,122,110	116,105				127	115			114,108	102	111,104,112,107,103	
R	171,147,140-144,152-155,127-133,135-138,151,123-125,148,164-166,121,159,160,156,134,126,143,146,169,170,110,123,157,167,122,161,105-108,113,139,168	150,101								112	163	149,109,114-120	162	111	102

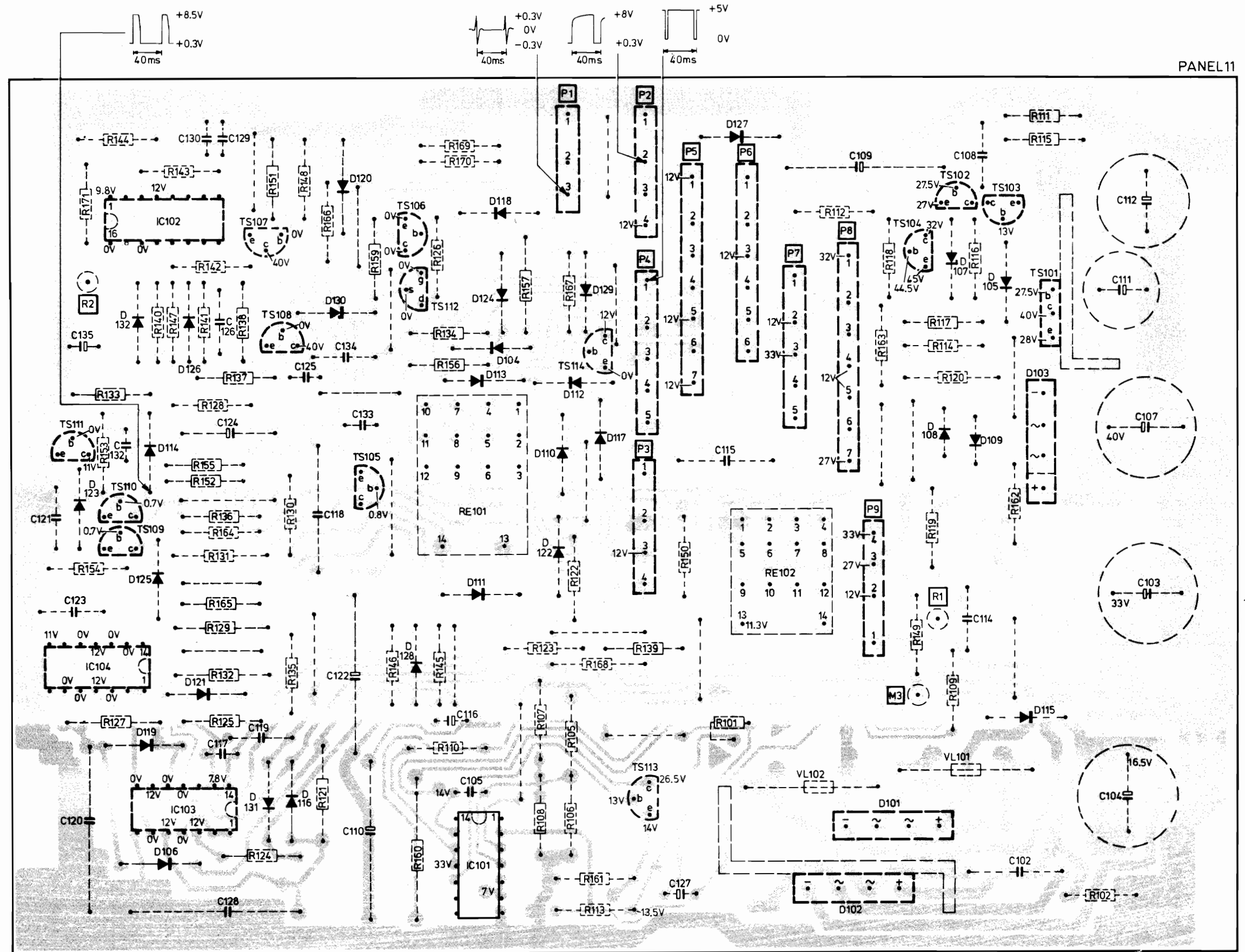

PANEL 11

CIRCUIT DIAGRAM D

R	324	327	321...323	325	330...332	329	333	326	328		
C	324	321	322						323		
MISC	S321	TS321	D322... 324	IC323	IC321	D321		IC322	SK323	SK321	SK322

PANEL 32

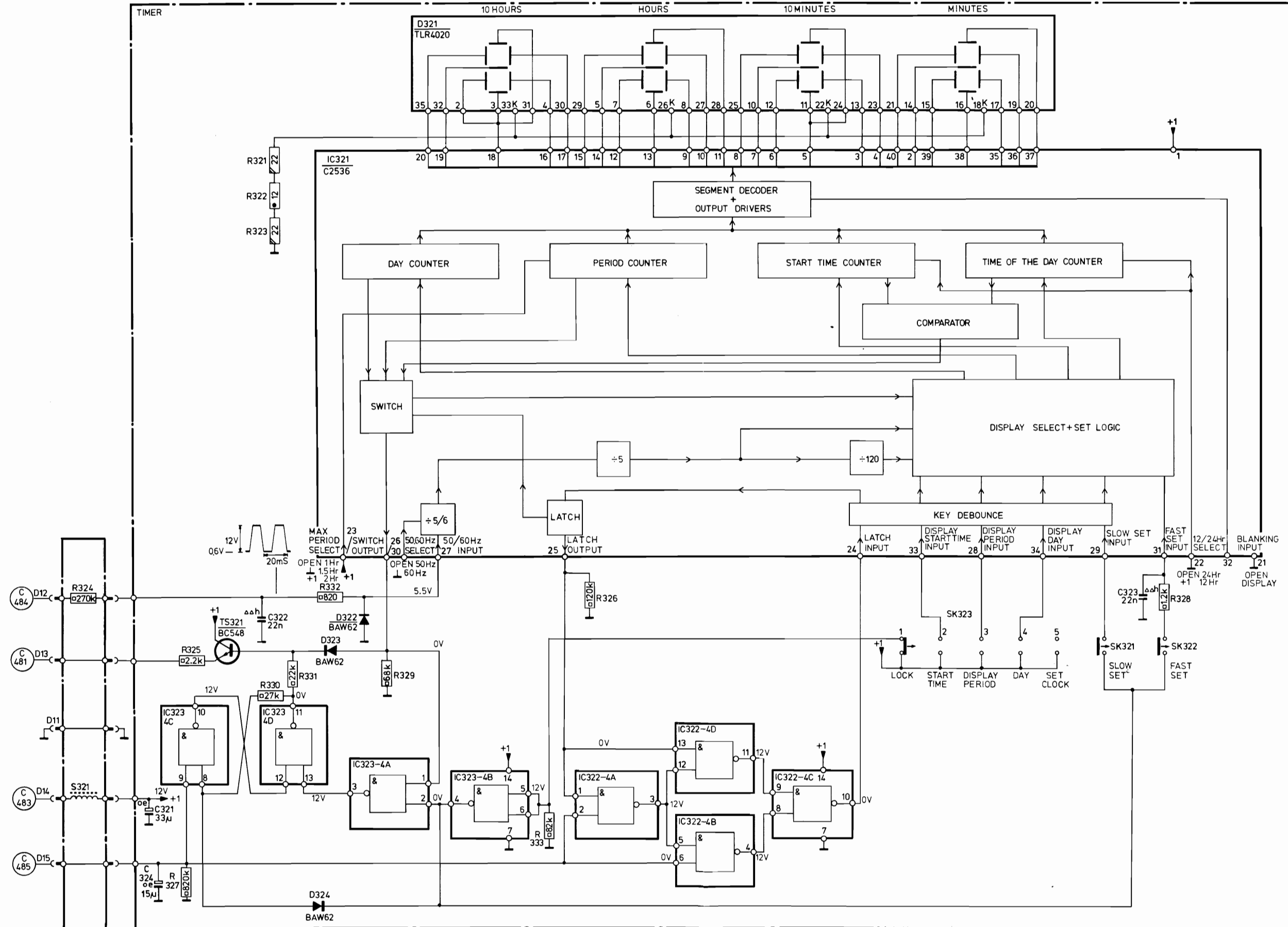

MISC.	D324.S321.SK321.D1A.D1	IC323.SK322	D323	TS321	D322	IC321.SK323	D321	IC322	MISC.
C		323	322			321			324
R	331.330.328.324		321.333.329.			323.332		325.326	327.322

PANEL 32

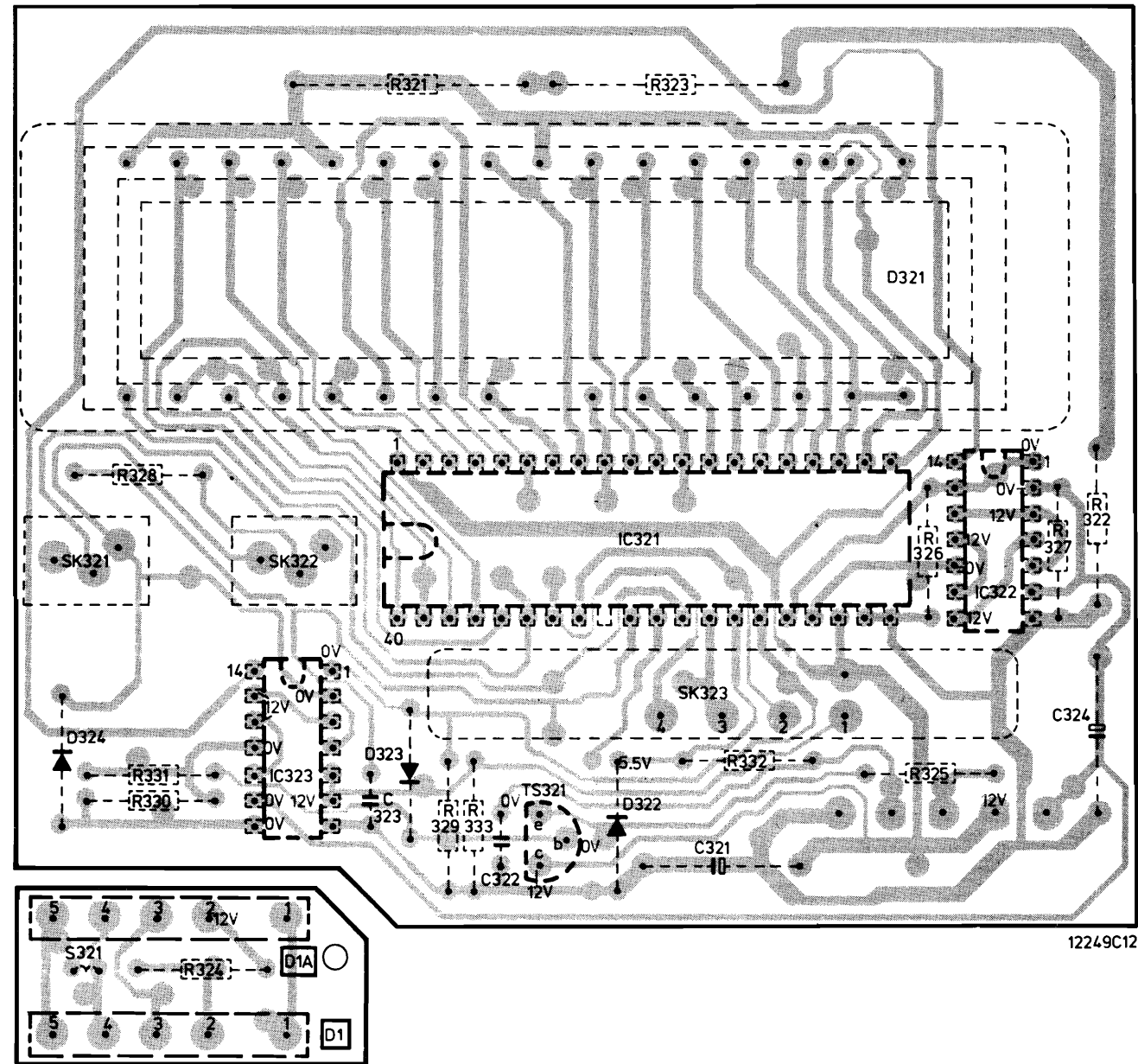

MISC.	IC322	D321	SK323.IC321	D322.	TS321	D323	SK322.IC323.D1A.D1	SK321.S321.D324	MISC.
C	324		321		322		323		
R	322.327		326.325				333.329.321		324.328.330.331

PANEL 32

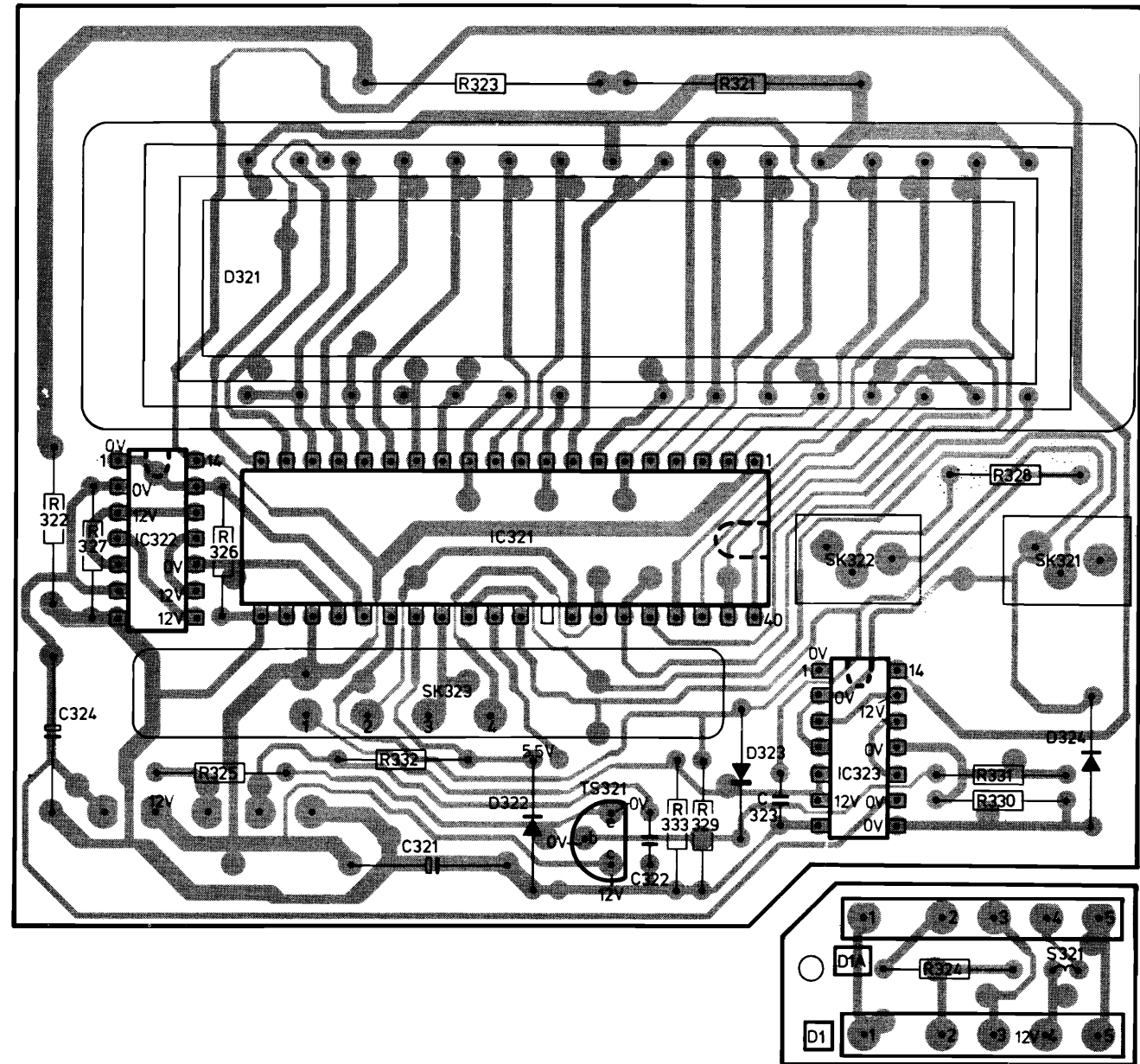

12248C12

CIRCUIT DIAGRAM D

R	324	327	325 332 321...323	329 330	326	333	331	335	328	334
C	324 322	321							323	
MISC	D322	IC322	TS321 IC321	D321 IC322	IC322, 323	IC323	SK323 IC322	SK321	SK322 IC323	TS322

PANEL 32

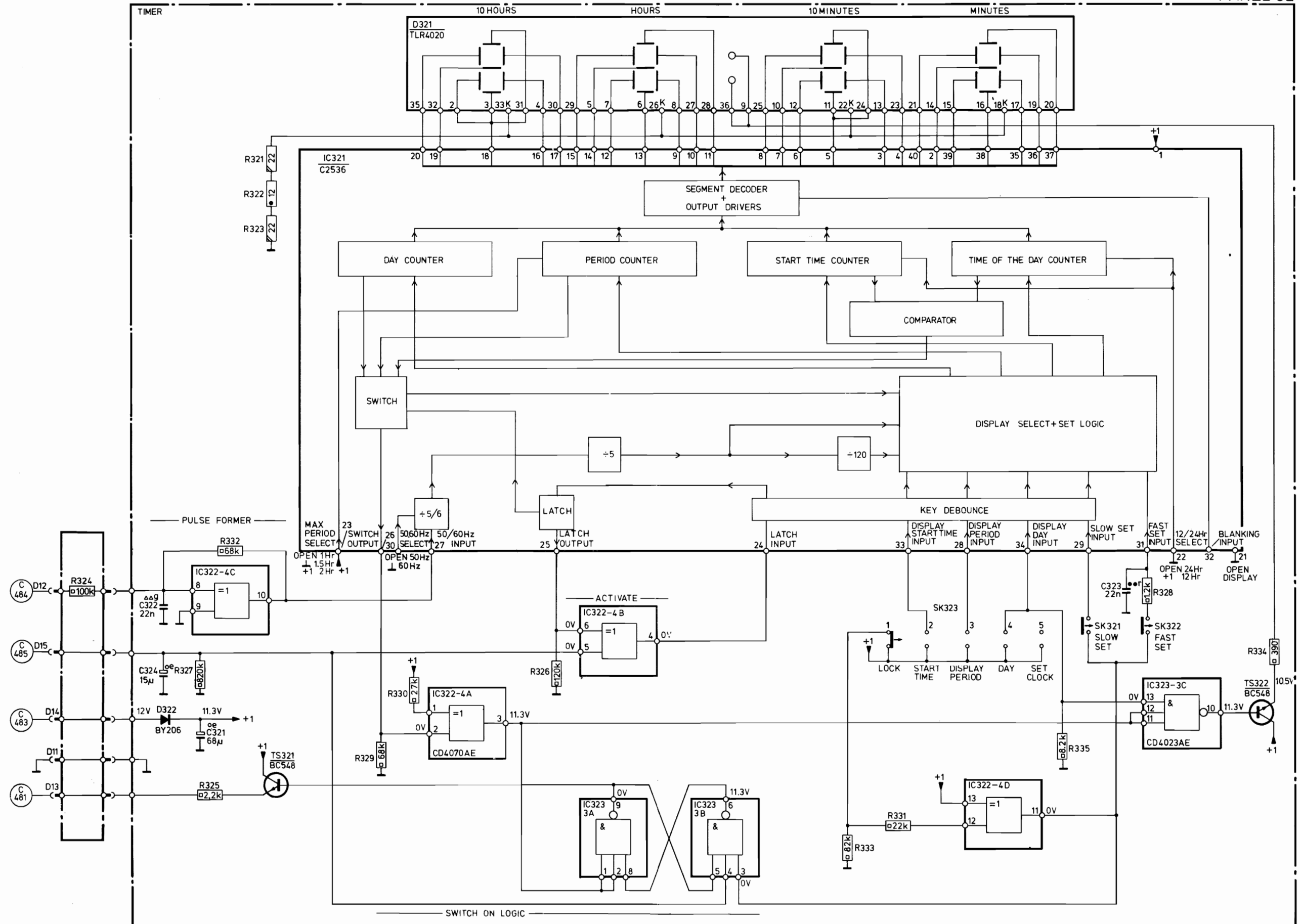

MISC	TS321,322 SK321 IC323 SK322	D321	IC322,321	SK323	D322
C	323		322		321
R	334 328 324	335 330 321 329	323 332 331 333		326 325 327 322

PANEL32

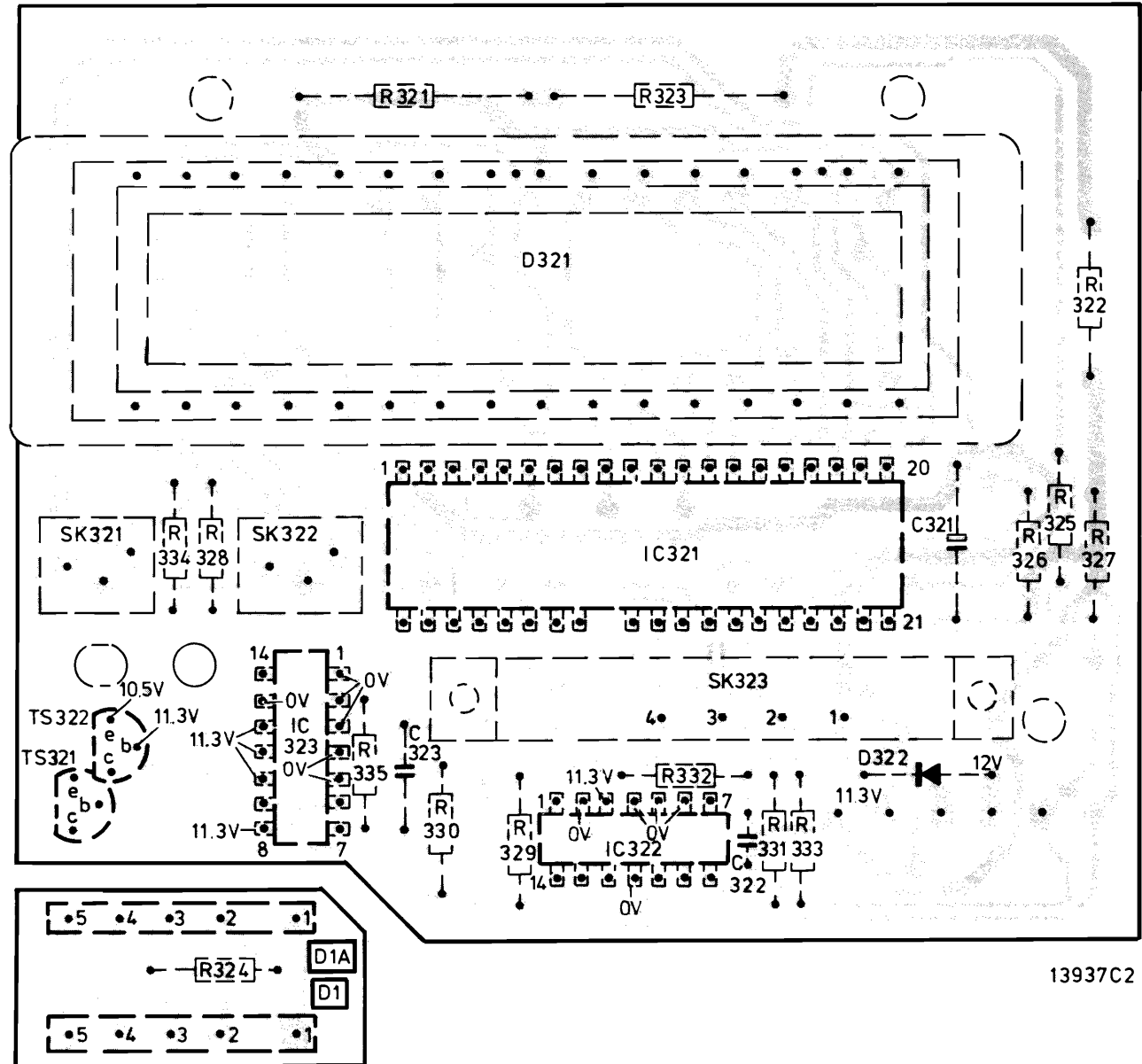

13937C2

MISC	D322	SK323	IC321,322	D321	SK322	IC323	SK321	TS322,321
C	324	321	322			323		
R	322 327 325 326		333 331 332 323		329	330 321 335		324 328 334

PANEL 32

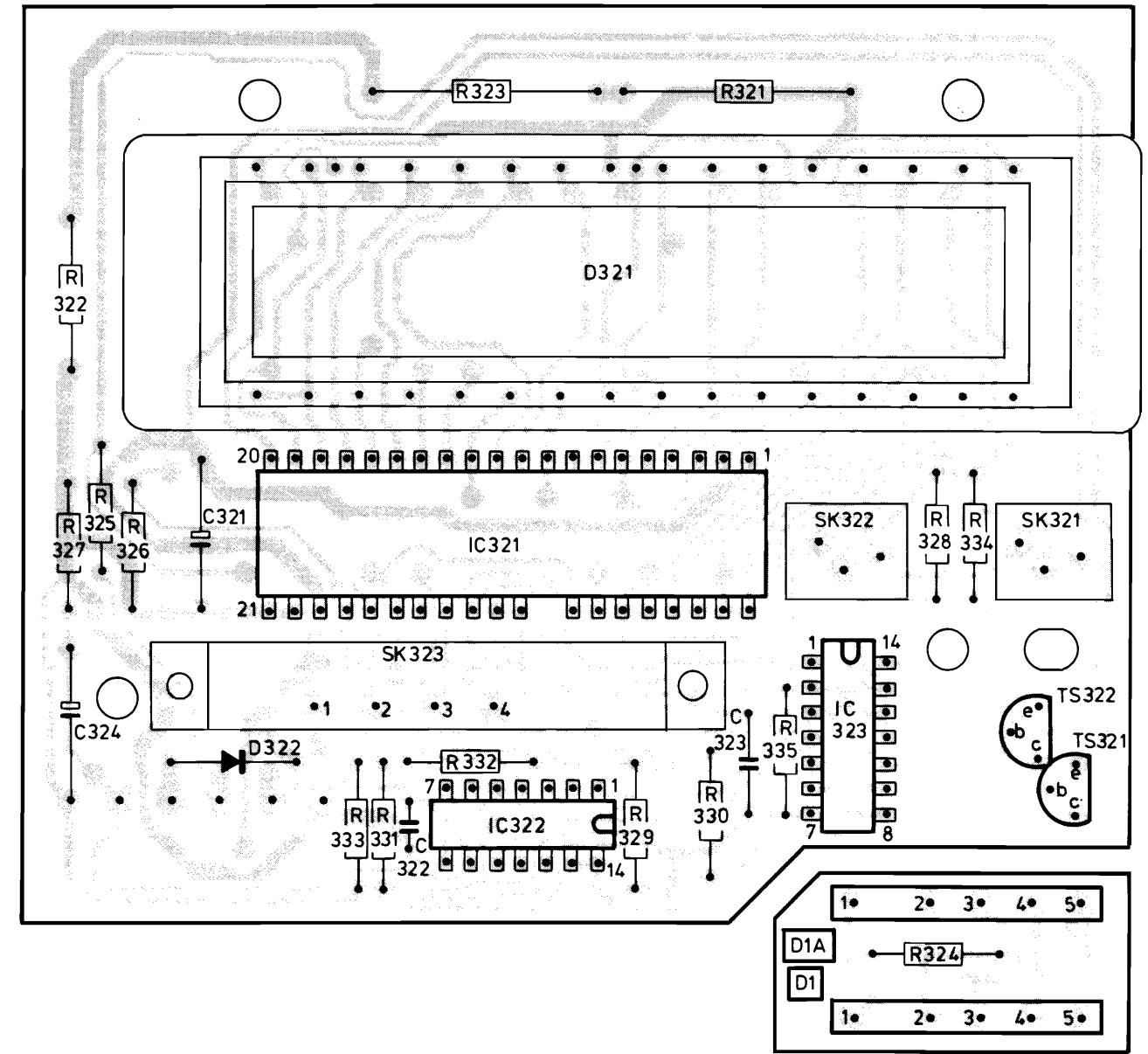

13936C2

MISC	D322	IC322-4A 4B	D321	IC321	SK 323	SK321	SK322	IC322-4CD
C	323 322 321							
R	324	326 325 327		333	332	325 329	331 334	321 322 325 328

PANEL 32

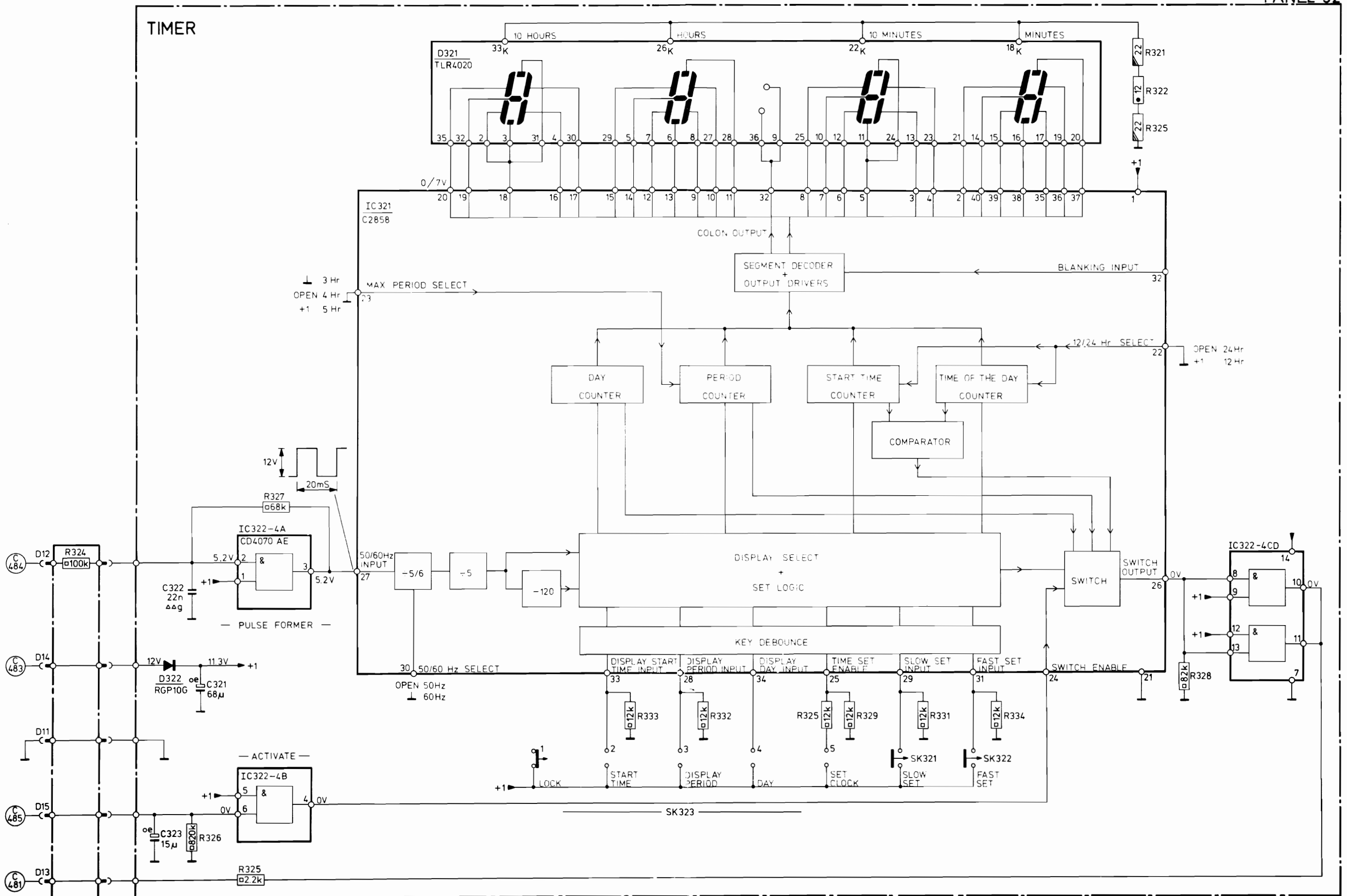

MISC	SK 321. D321	SK 322. IC 322	IC 321. SK 323	D322
C				321 323
R	324	328. 331. 334. 321 . 335	323. 330. 332 . 333. 327	329. 325 326 322

MISC	D322	SK 323. IC 321	IC 322. SK 322	D321. SK 321
C	323	321		
R	322. 326. 325. 329	327. 333 . 332. 330. 323. 321. 335	334. 331. 328	324

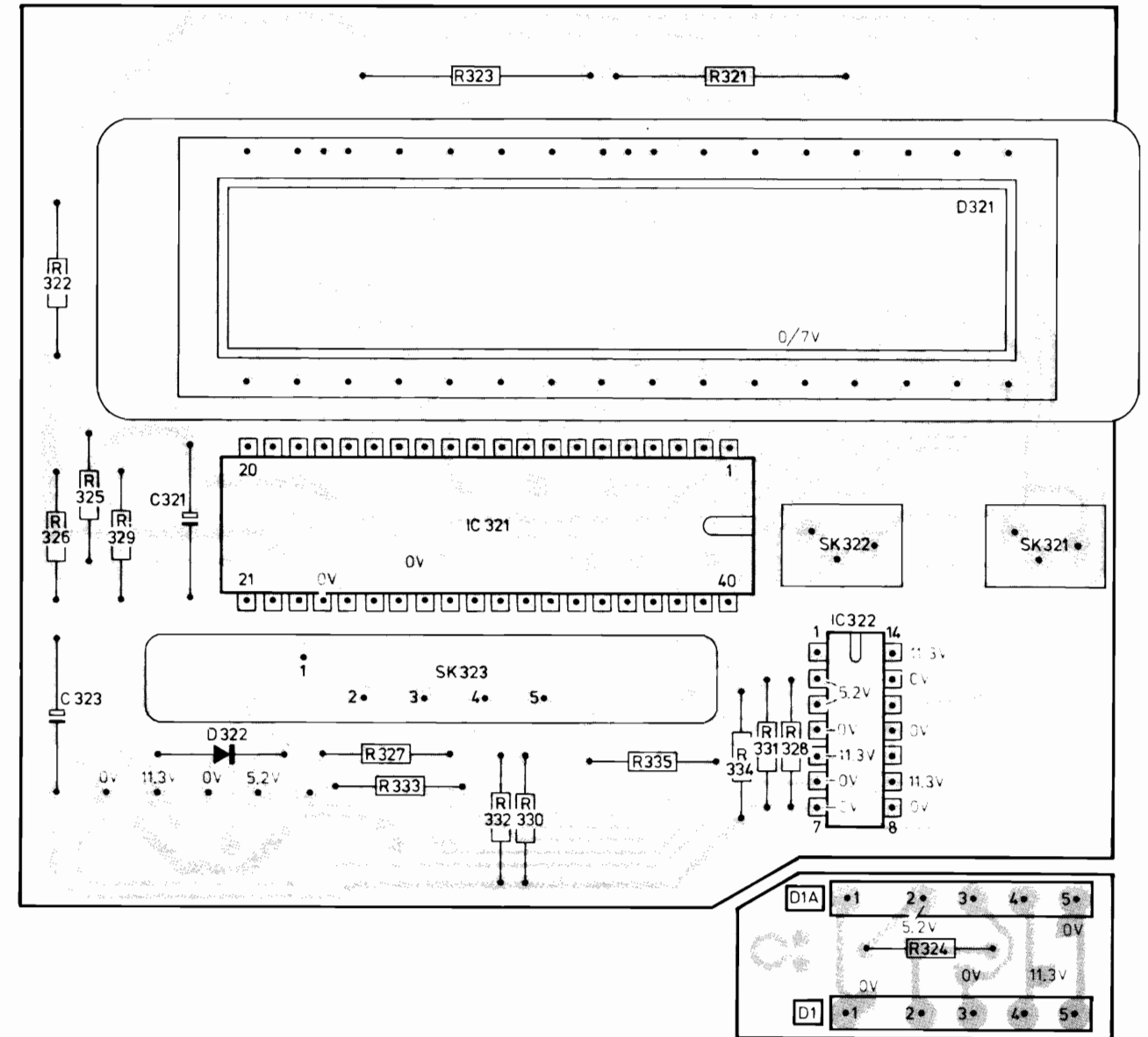
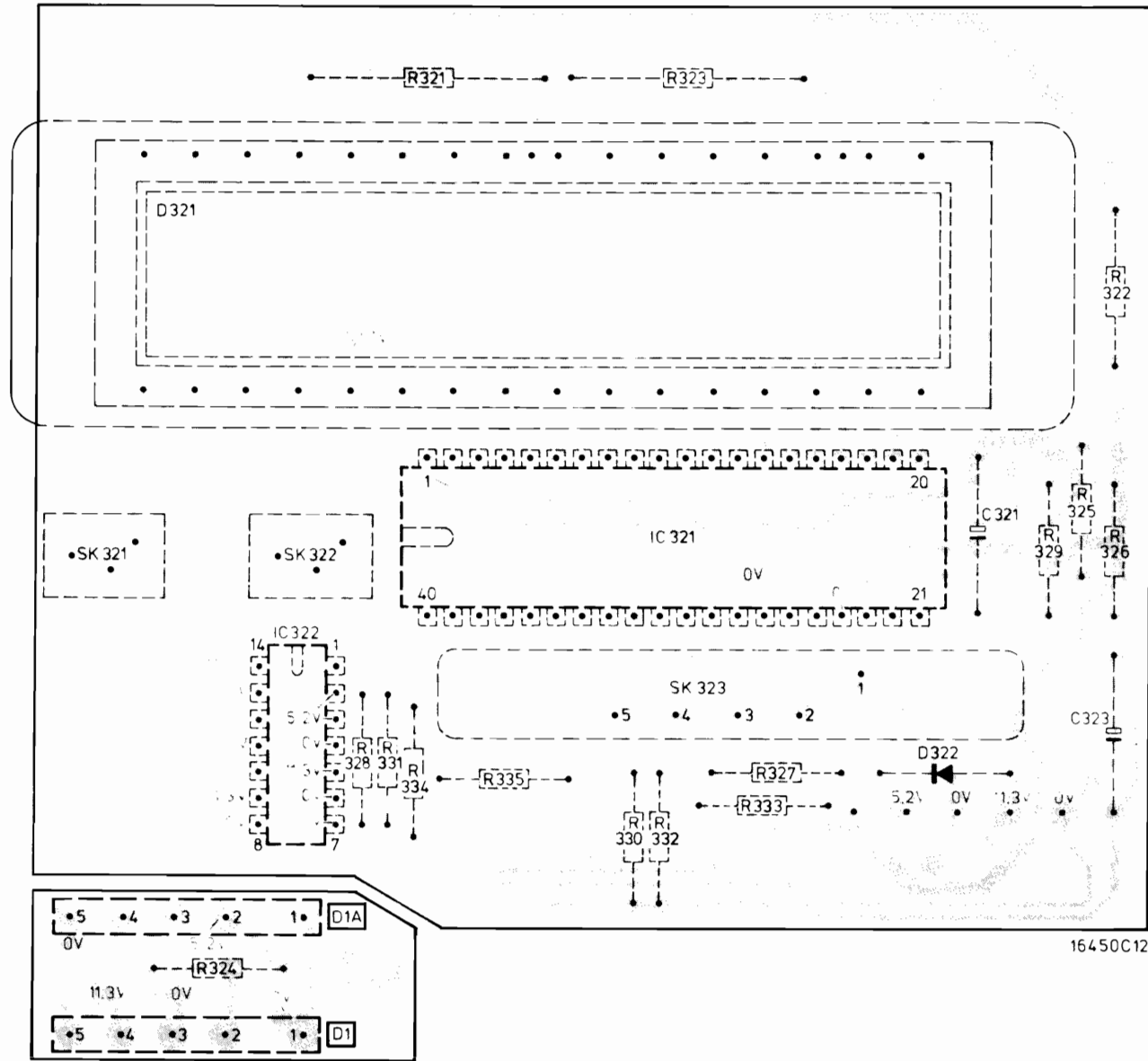

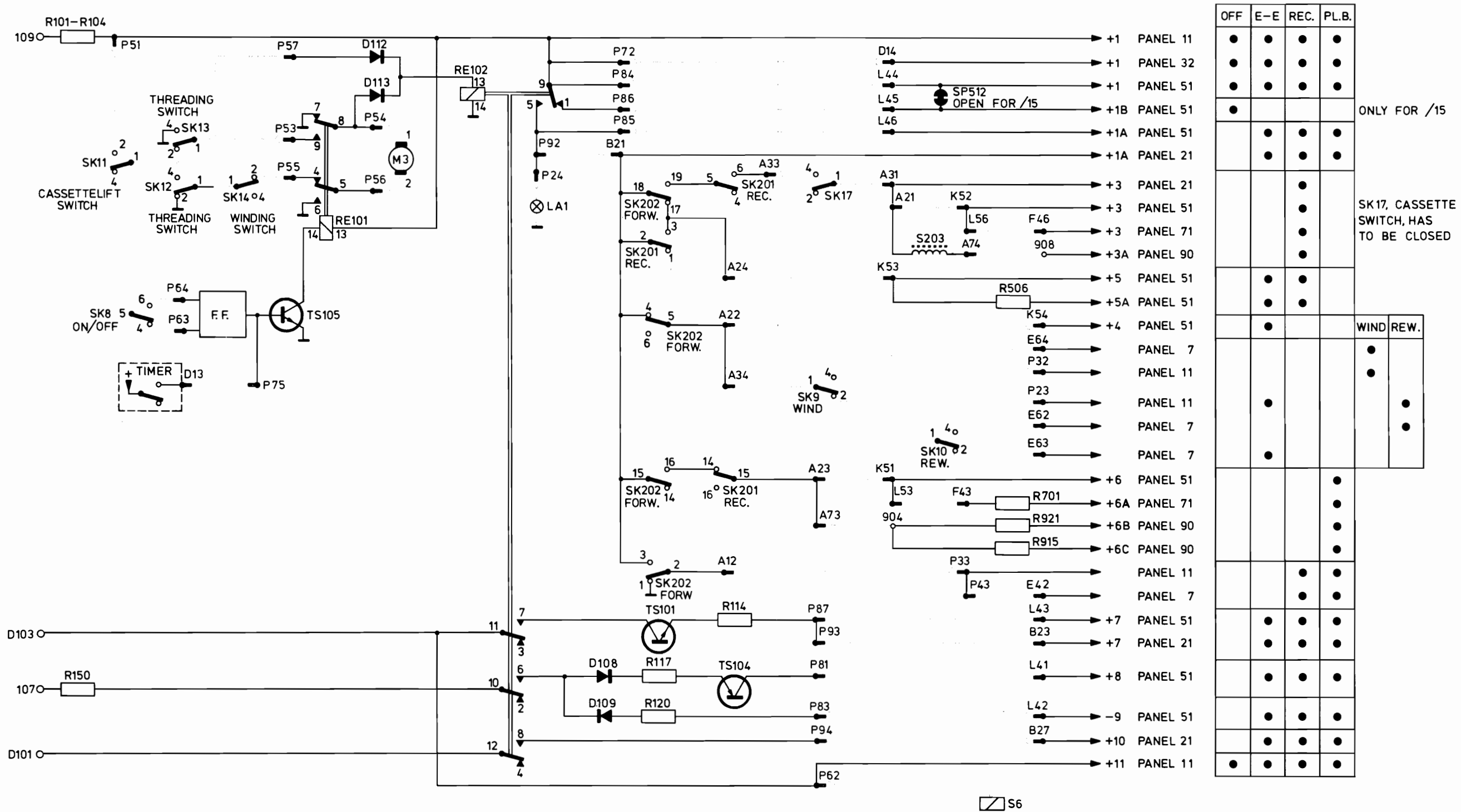

	OFF	E-E	REC.	PL.B.
+1 PANEL 11	●	●	●	●
+1 PANEL 32	●	●	●	●
+1 PANEL 51	●	●	●	●
+1B PANEL 51	●			
ONLY FOR /15				
+1A PANEL 51		●	●	●
+1A PANEL 21		●	●	●
+3 PANEL 21			●	
+3 PANEL 51			●	
+3 PANEL 71			●	
+3A PANEL 90			●	
+5 PANEL 51		●	●	
+5A PANEL 51		●	●	
+4 PANEL 51		●		
PANEL 7				WIND
PANEL 11				REW.
PANEL 11		●		
PANEL 7		●		
PANEL 7		●		
PANEL 7		●		
+6 PANEL 51			●	
+6A PANEL 71			●	
+6B PANEL 90			●	
+6C PANEL 90			●	
PANEL 11			●	
PANEL 7			●	
PANEL 7			●	
PANEL 7			●	
+7 PANEL 51		●	●	●
+7 PANEL 21		●	●	●
+8 PANEL 51		●	●	●
-9 PANEL 51		●	●	●
+10 PANEL 21		●	●	●
+11 PANEL 11	●	●	●	●

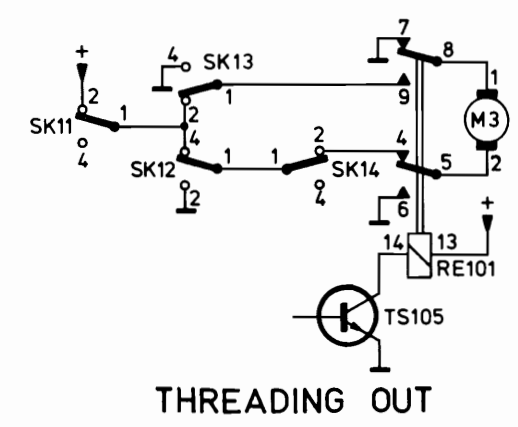
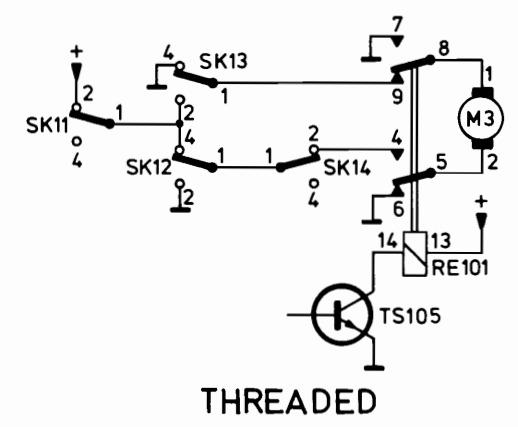
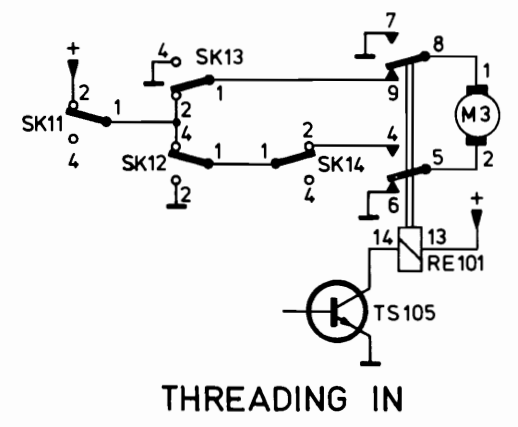
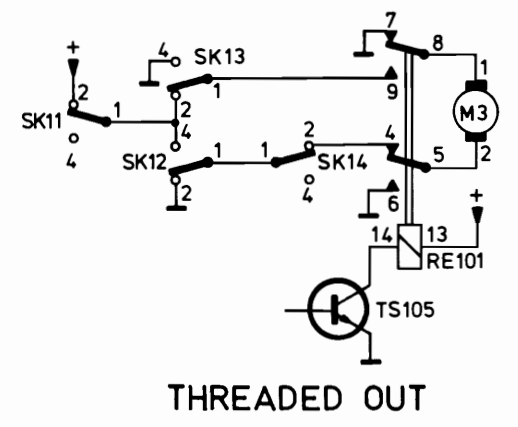

MAIN WIRING DIAGRAM A

R	348	344	347	343	346	342	345	341	524	522	525	523	521 519	527	540	541	518	517	542	502 532	531	530	511	510	710 711	704	708	703 709 701	702	
C	903	904 910 909 905 906 901 902 907 908				911 924	925 913 912	915 923	520	519 514 512 511	526	513 504	537 529 538	516	515	539 514	533	536	507	505	516 517	518	508	502 515 501	510	509 504 508 512 513 505	708	703 706	707	711
TS	901	902 903			904	906	905		509	506		508	505	504	501	503										702	701	712 710 702	703	
MISC	SK319 311a b	SK315b a	SK312a b	SK316b a	SK313a b	SK317b a	SK314a b	SK318b a	US39 513E	US14 515	US12E KT502	DS11	VS101 5506	BU3 5507	SS01 US51 TD501	US31 507 552	US502 503 506 505 5504	US08	DS01	SS05	DS09	DS07 502 US53	DS03	BU2	5703 U731	U732 734 5702 705 0301 TD701	5704	5706	D701	

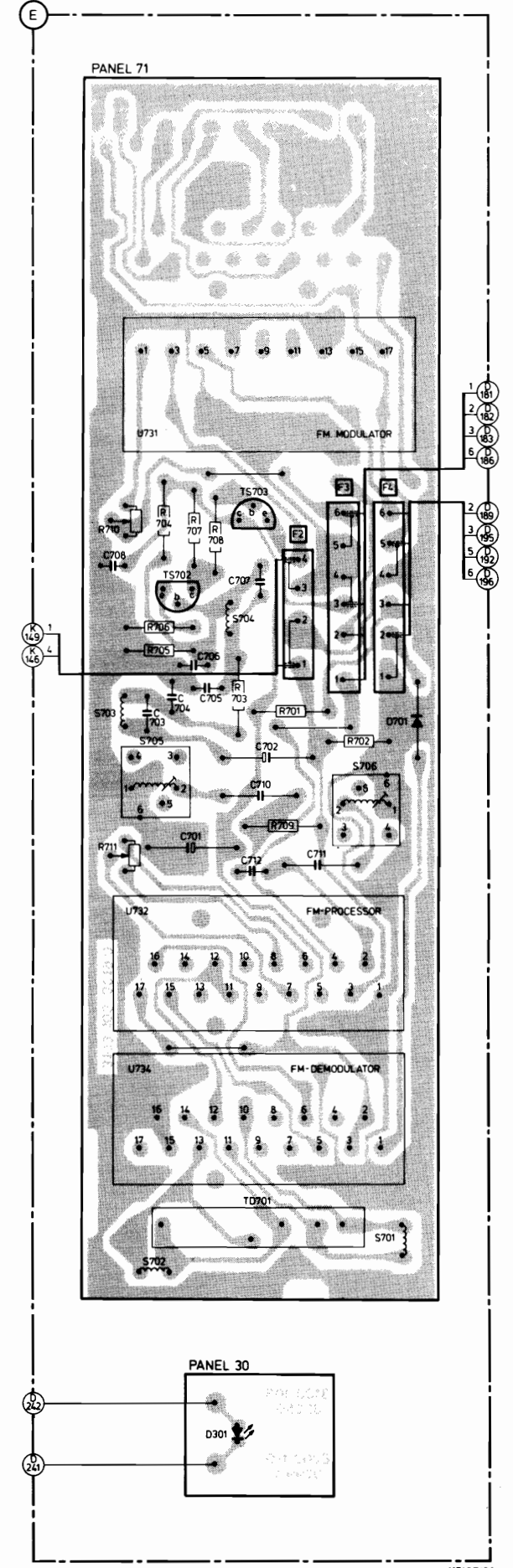
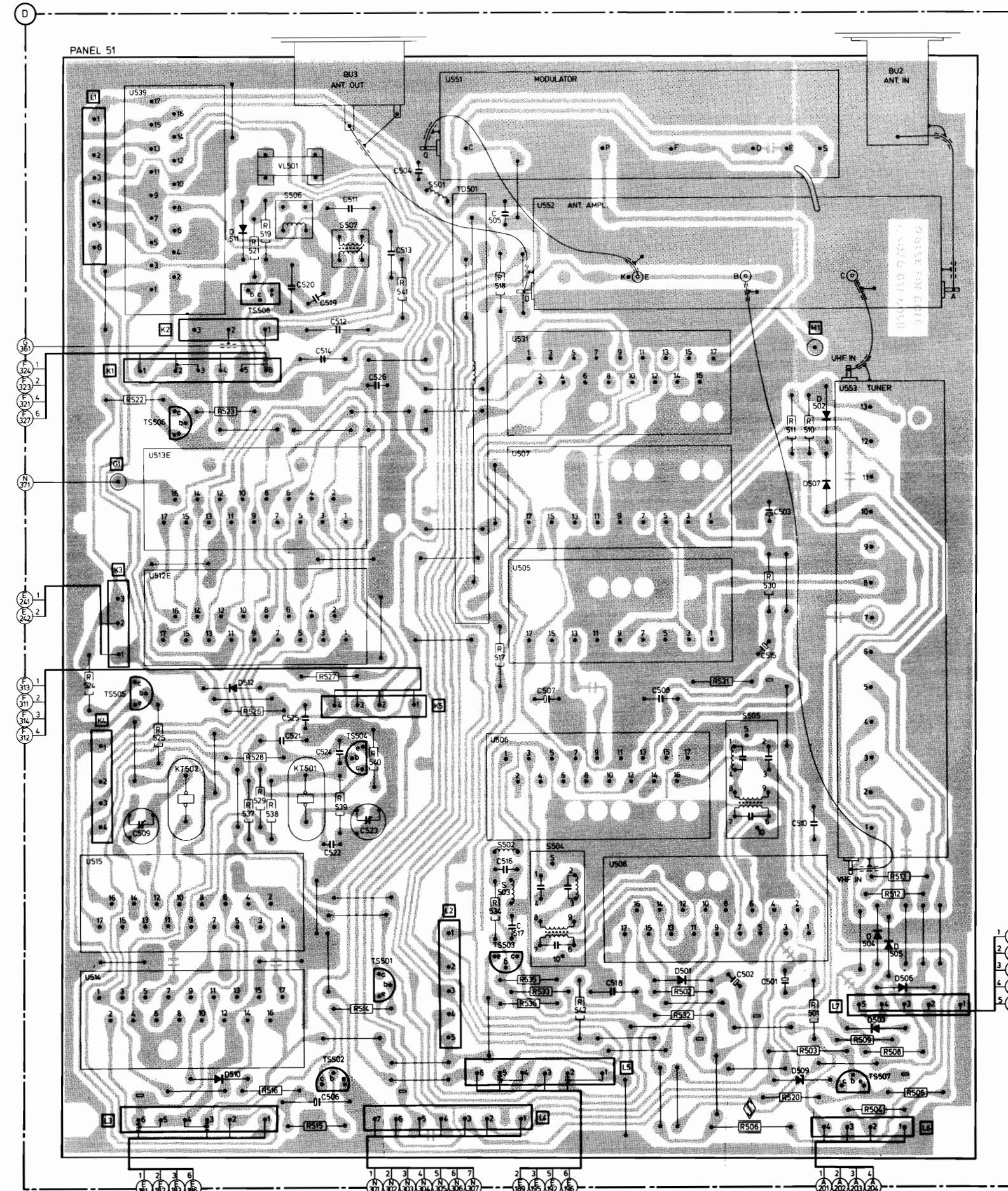
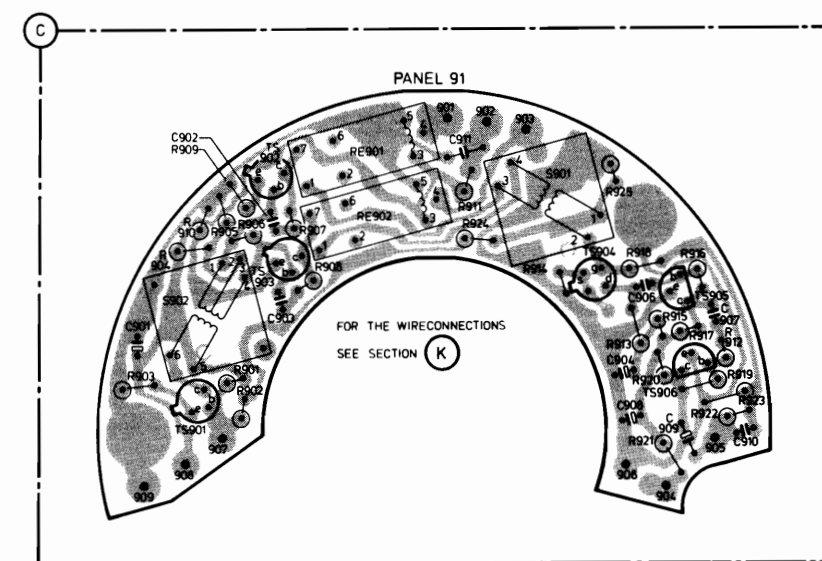
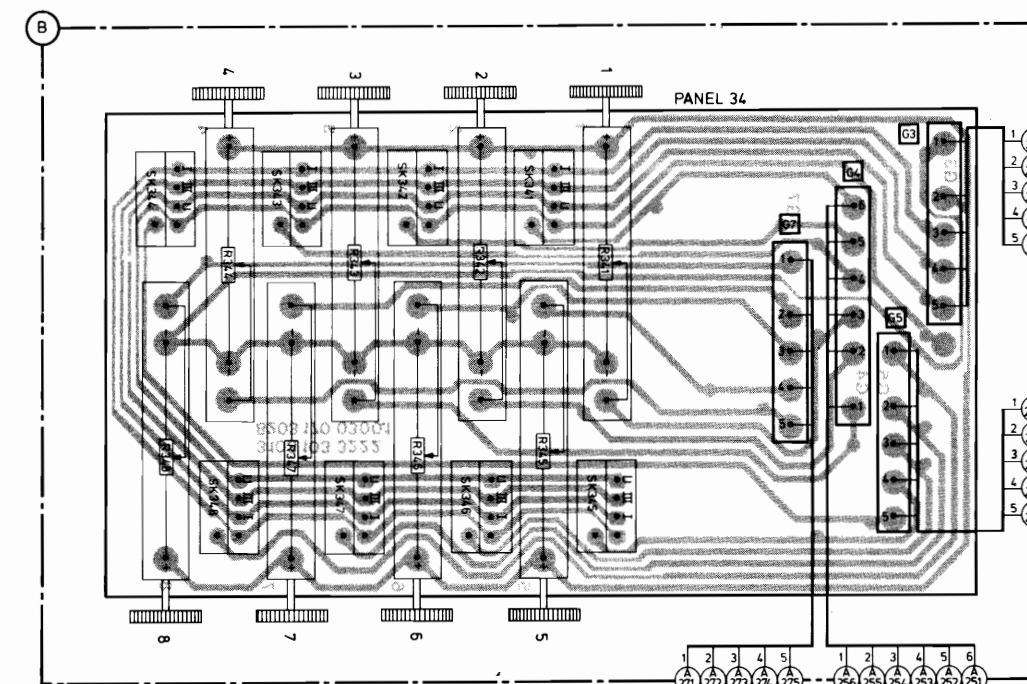
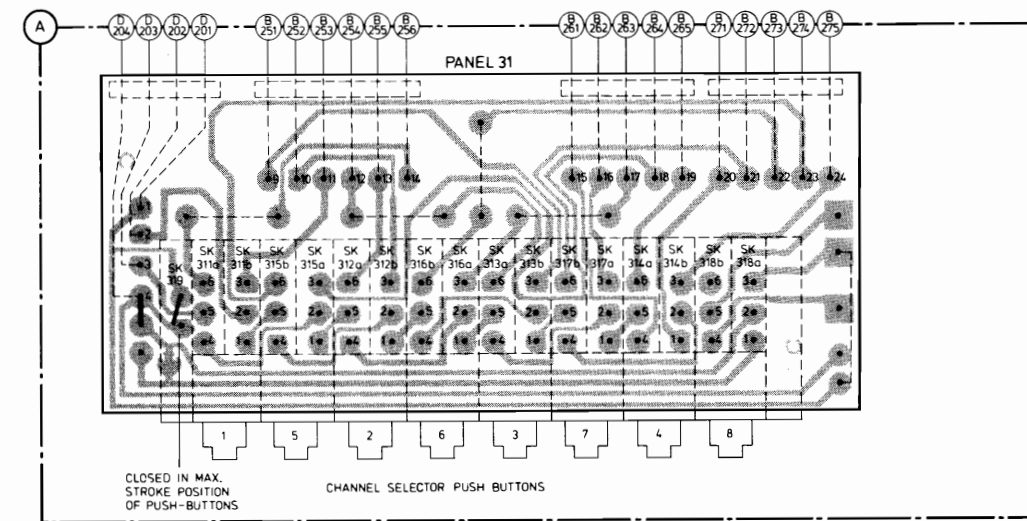

MAIN WIRING DIAGRAM B

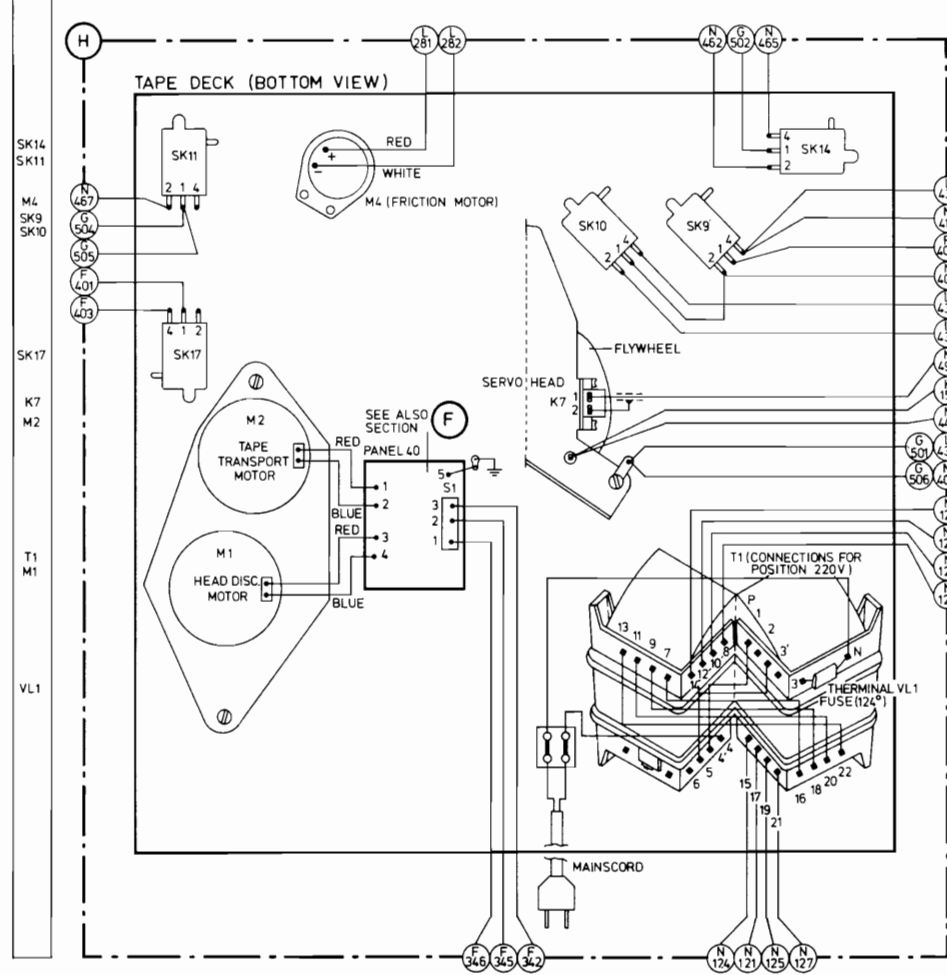
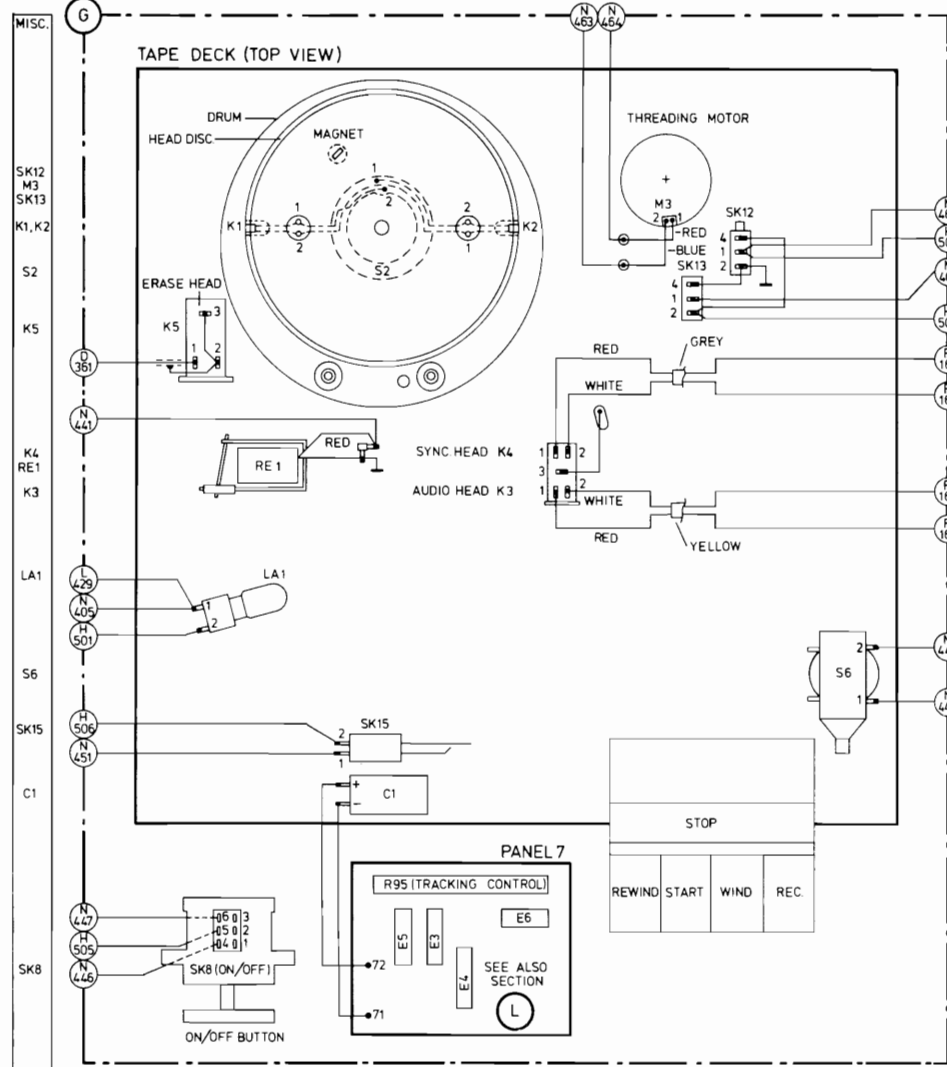
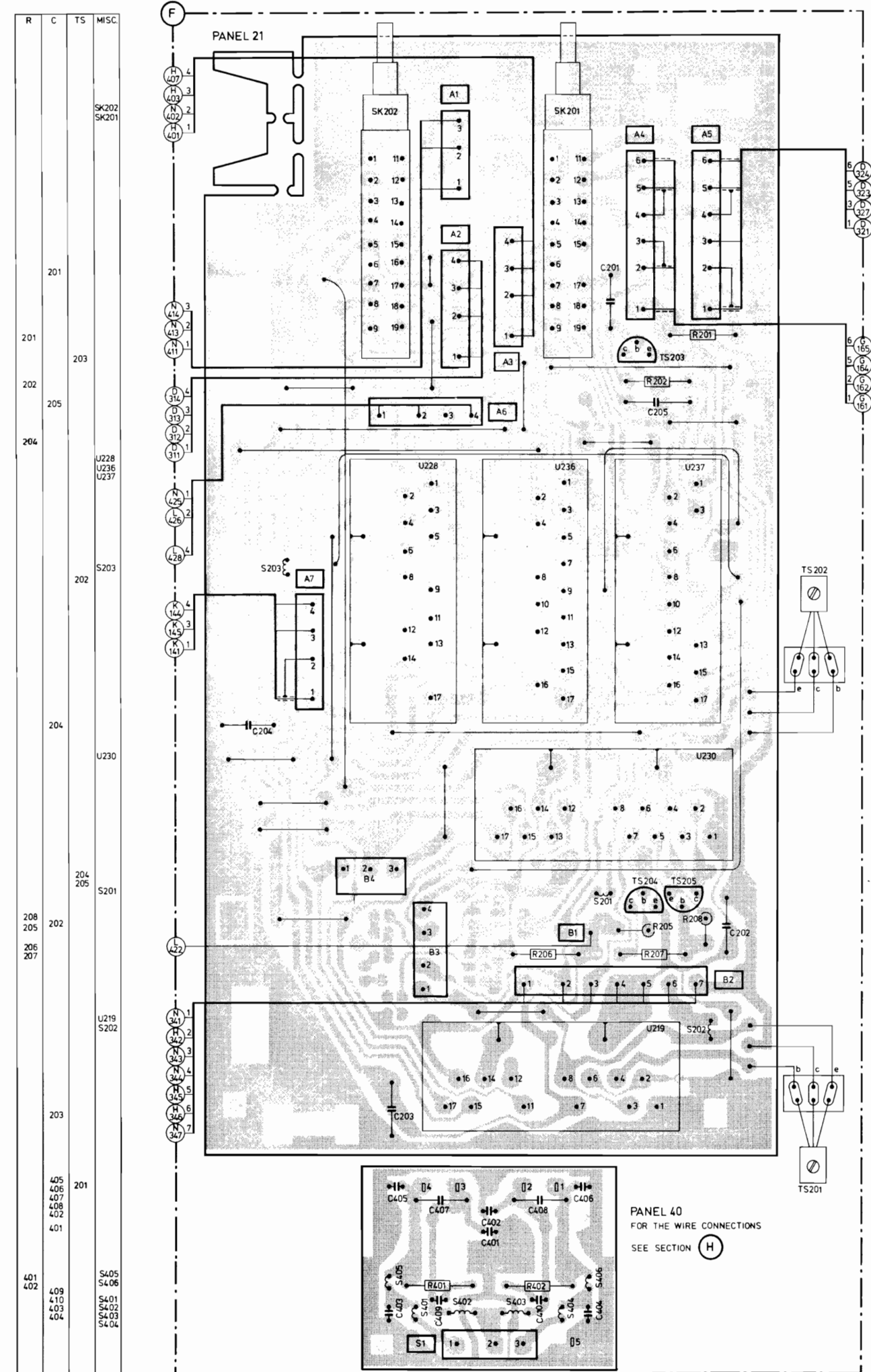

R	127,140-142,165,131,132,125,128,124,123,164	121	146,160,145	89-91	86,88,84	95,85,80-83,76,92-94,77,74,79,78,71-73	110	118,148,118,109	324	102
C	120	123	127,128,129,130,126,124,125,125,118,122,134,133	110	105,72	159,158,156,134,126,143,144,137	113	160,161,85	162,111,115	104
TS	109-111	107,108	105	112,106	105	77,76	73,74	71	109	108
MISC	K6, S1, SK16, D119, 106, IC103, IC104, D123, 125, 114, 126, IC102, D121	D116, D130, 120	D81, 83, 85, IC101, D84, 72, 71, 77, RE101, D128, 111, 113, 126, 104, 124, 118, 122, 110, 112, 115, 117	D79, 82, 87, 86, 74, D127, RE102	D8, 8, 73, VL102, D102, D101, VL101, D107, 109	D105, D103	IC322, IC321, D321, S321, SK322, SK321, IC323	SK322, SK321, IC323	111, 107, 112, 103	1

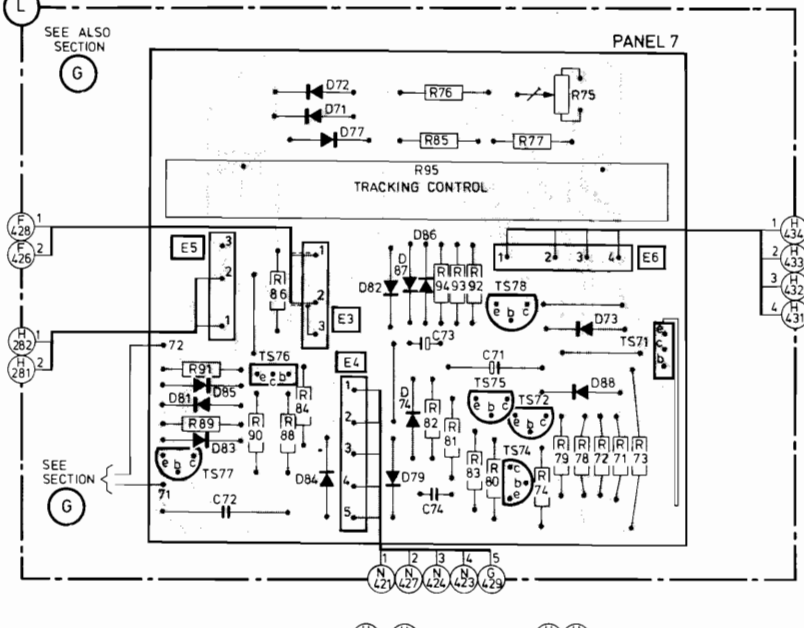
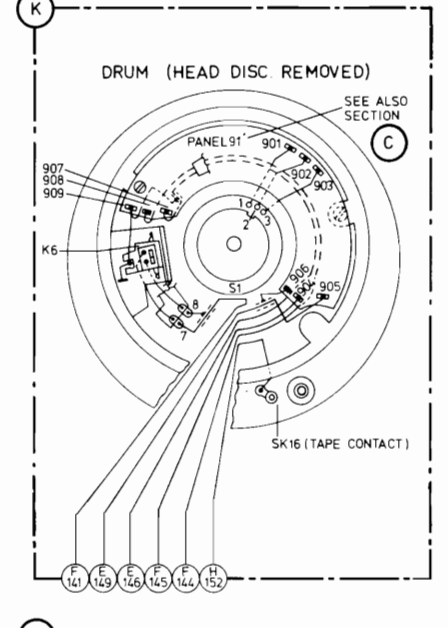

MAIN WIRING DIAGRAM B (ADAPTED TO FACTORYCODE WD 02)

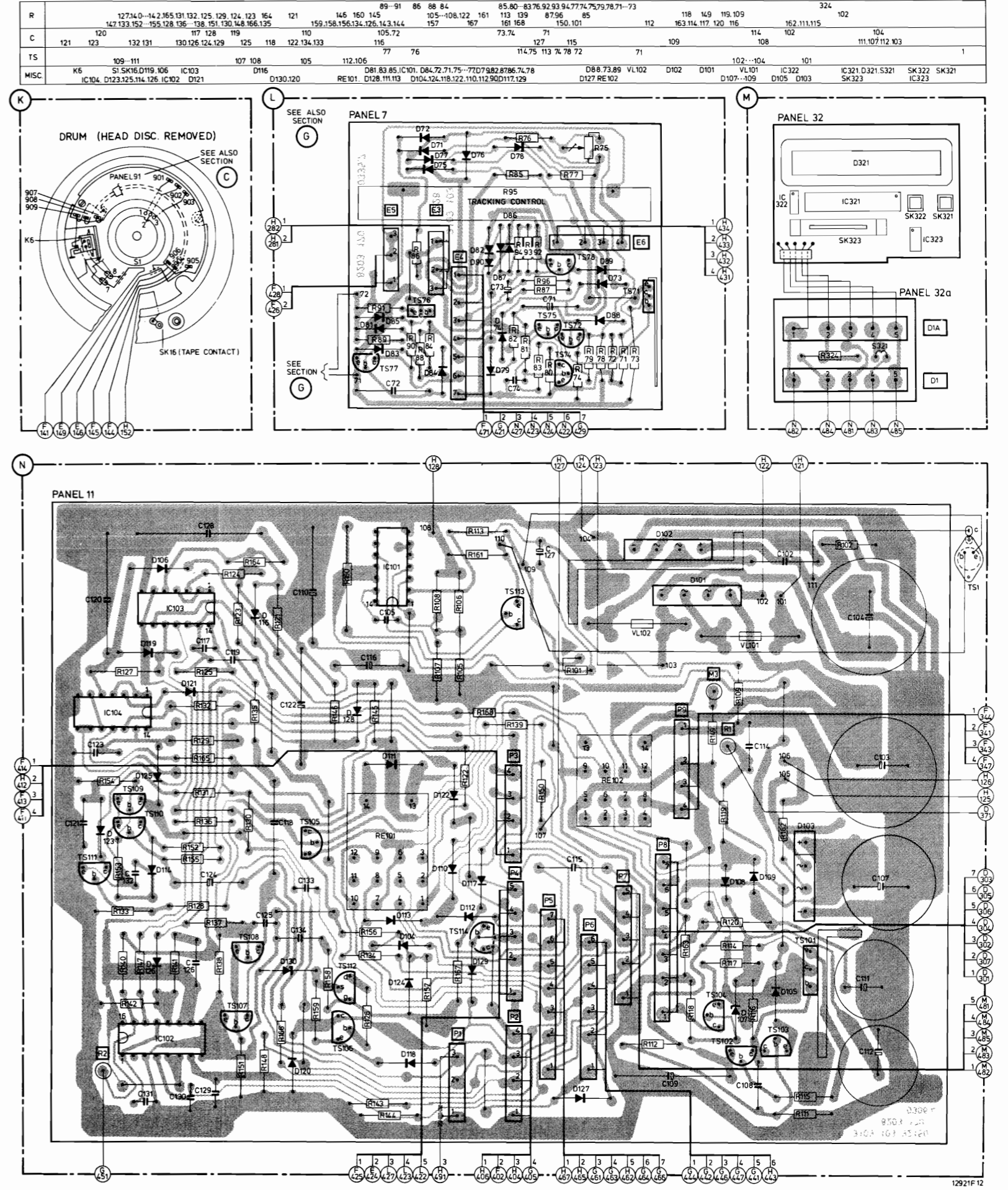
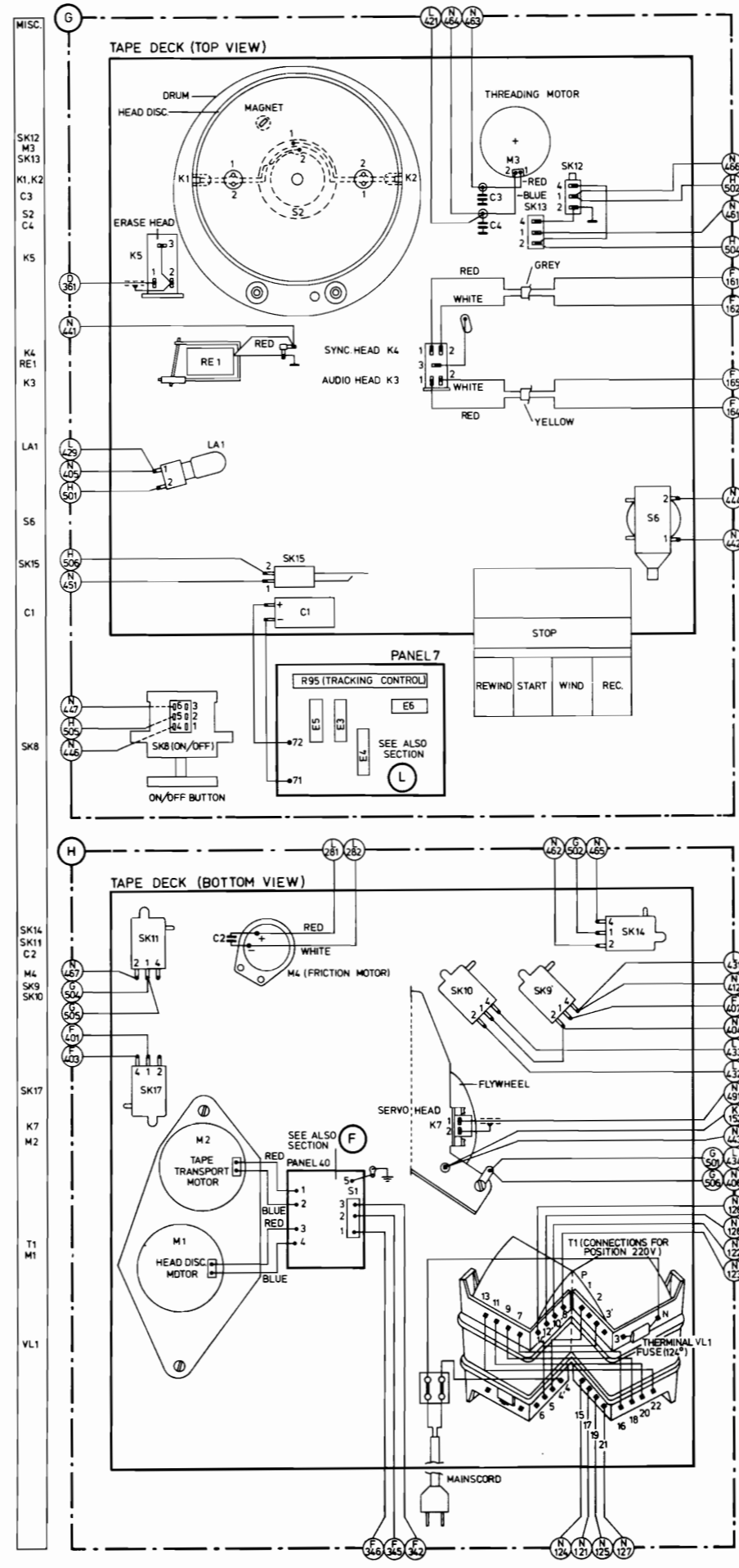
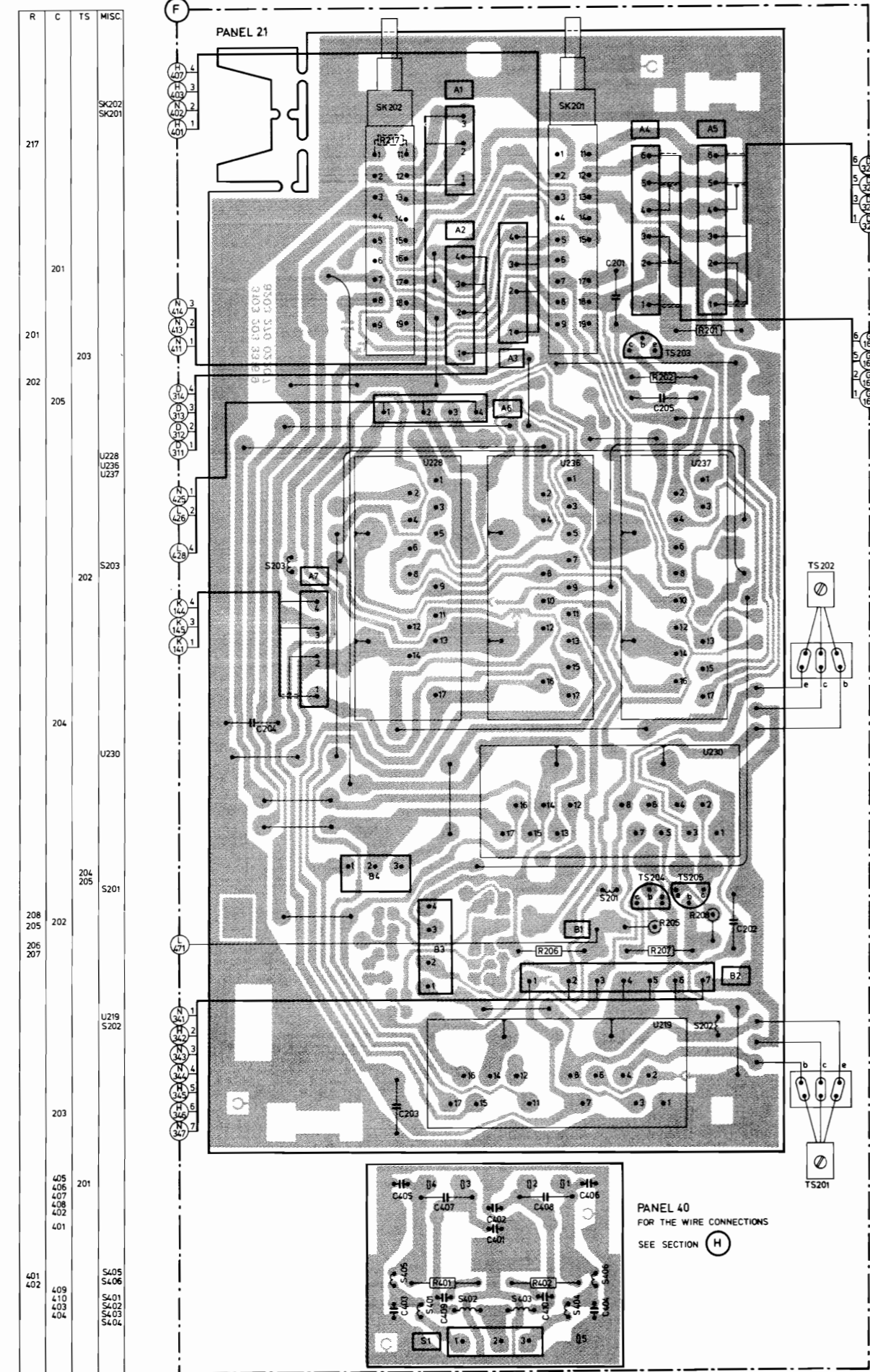

V. EXPLODED VIEWS AND SERVICE PARTS

Contents	Page
1. Exploded view: cabinet	3
tape deck	4
2. List of mechanical parts	5
3. List of auxiliaries	6
4. List of electrical parts	7
5. List of connecting cables	8

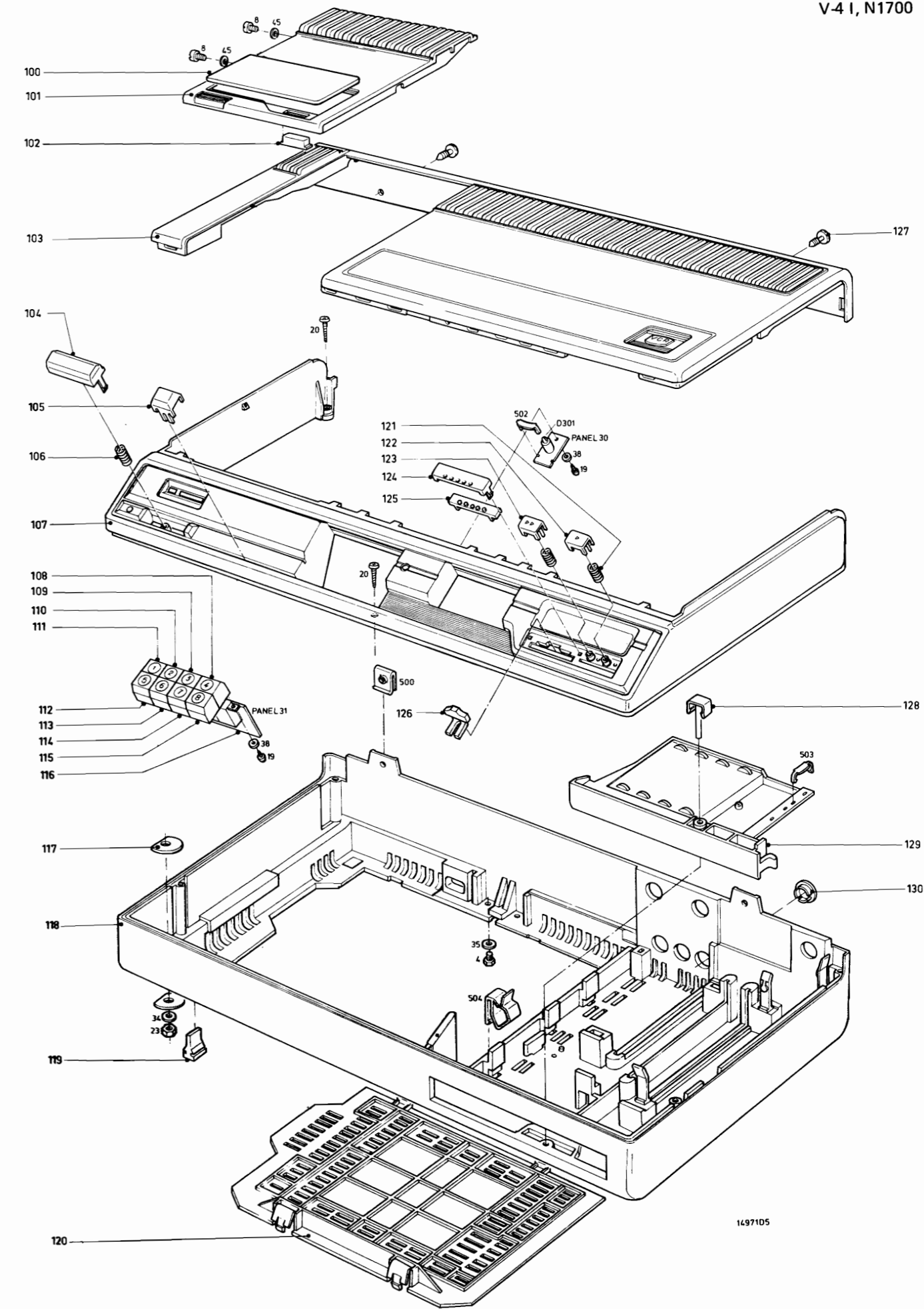

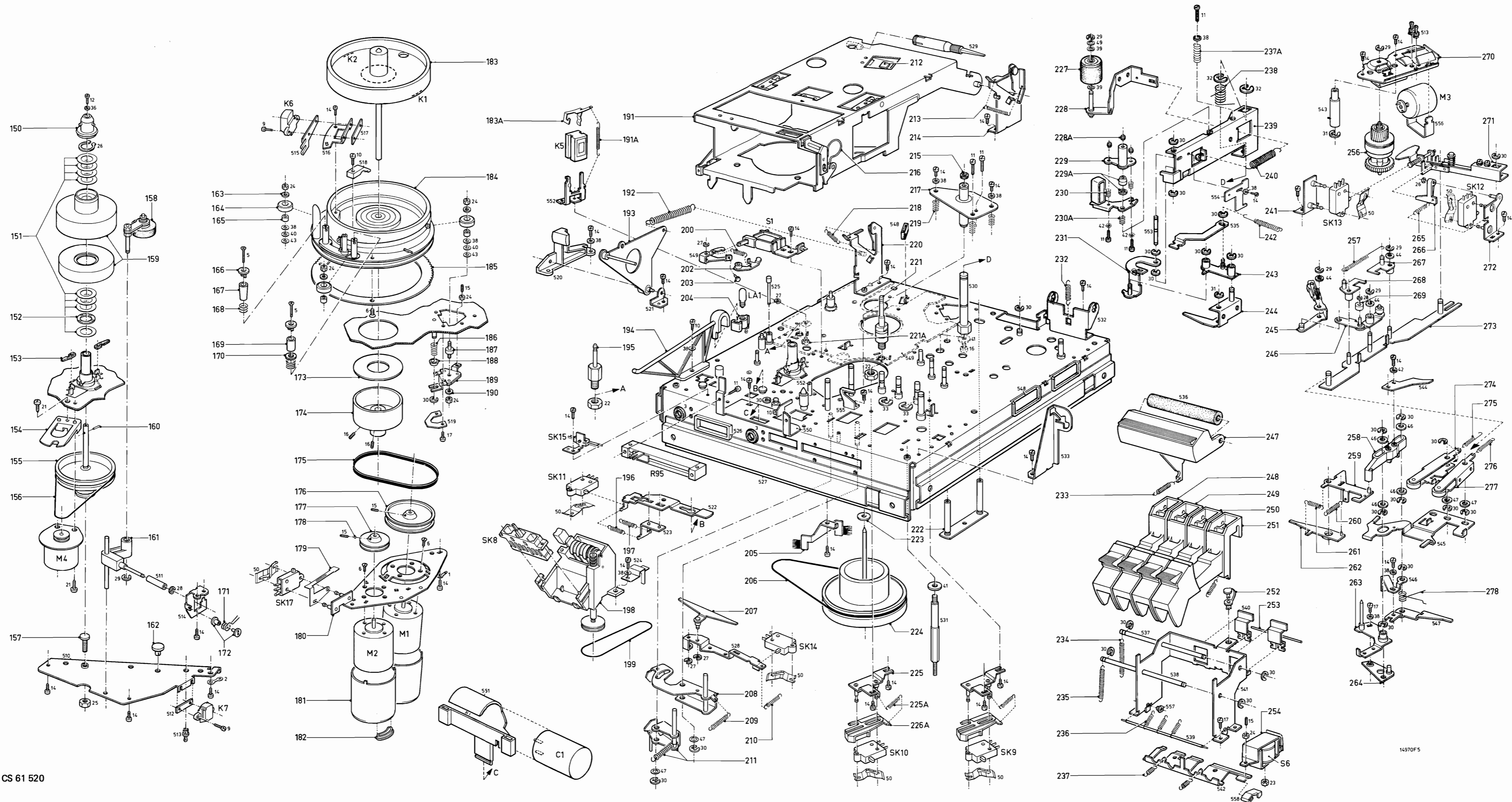

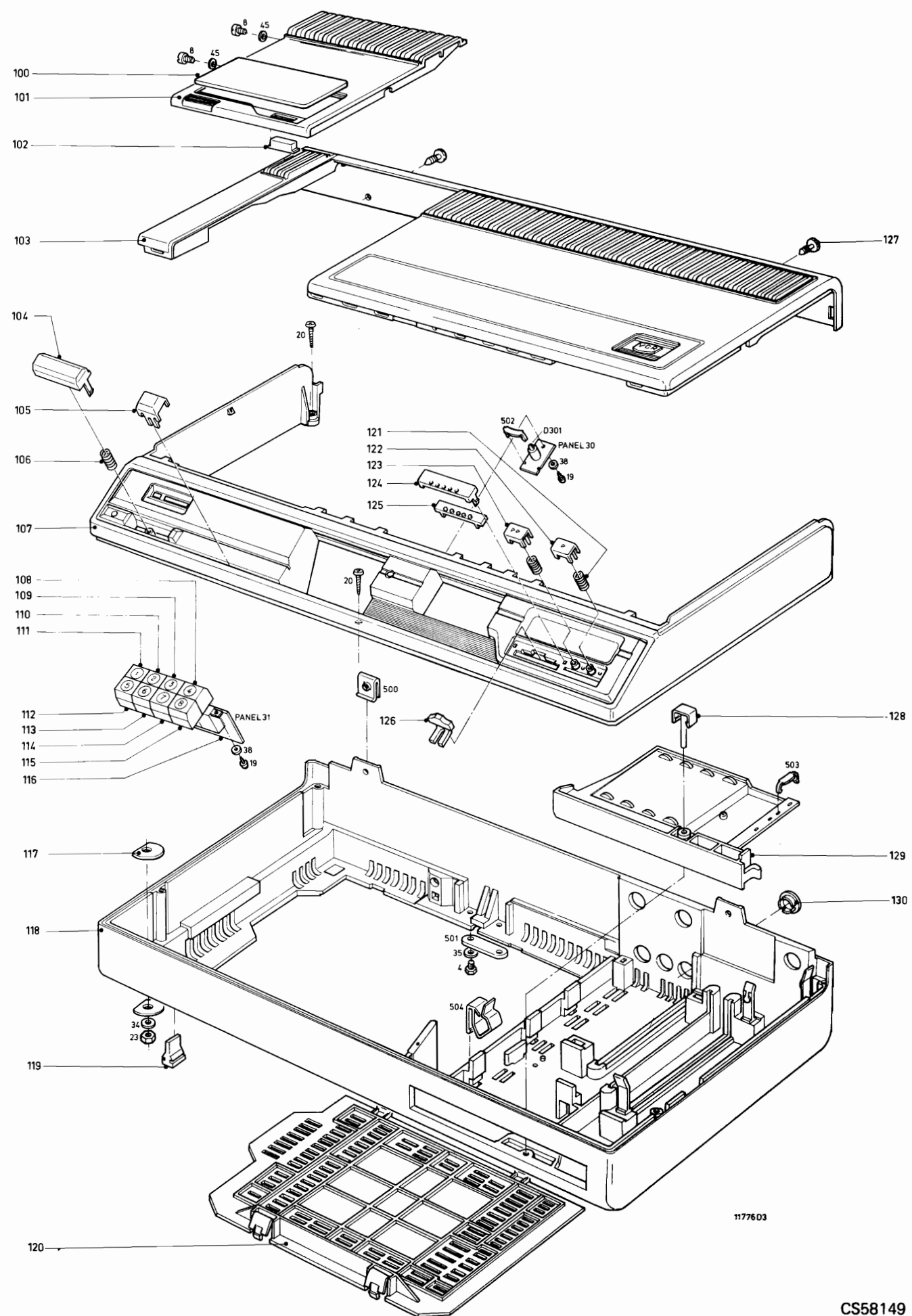

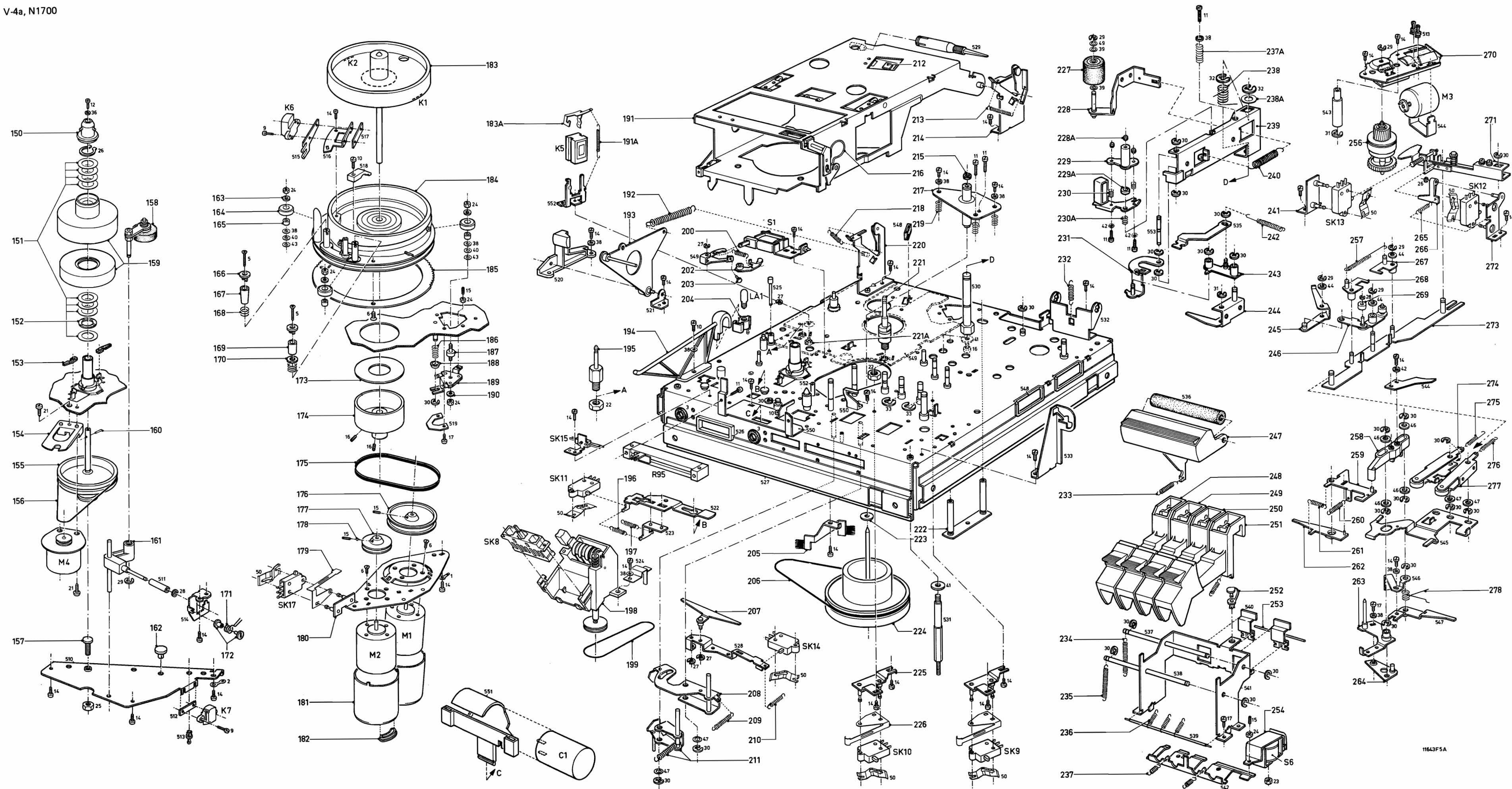

11643F 5A

MECHANICAL PARTS LIST

Mounting material

1	soldering tag 3x18 mm	4822 290 30059
2	soldering tag 3x12 mm	5322 290 30079
3	grommet	4822 325 60031
4	screw M3x14	5322 500 14001
5	screw M3x16x10	4822 502 10095
6	screw M3x5	4822 502 10176
7	screw M3x5	4822 502 10558
8	screw M2, 5x5	4822 502 10951
9	screw M2x8	4822 502 10681
10	screw M3x10	4822 502 10689
11	screw M3x15	4822 502 10691
12	screw M2, 5x9	4822 502 10909
13	screw M3x5	4822 502 11022
14	screw M3x6	4822 502 11064
15	grub screw M3x6	4822 502 11107
16	grub screw M4x6	4822 502 11109
17	screw M3x4	4822 502 11189
18	screw	4822 502 30085
19	screw	4822 502 30091
20	screw	4822 502 30092
21	screw	5322 502 84012
22	nut M8	4822 505 10009
23	nut M4	4822 505 10262
24	nut M3	4822 505 10325
25	nut M5	4822 505 10327
26	retaining ring 10 mm	4822 530 70028
27	retaining ring 2,3 mm	4822 530 70043
28	retaining ring 1,9 mm	4822 530 70122
29	retaining ring 3,2 mm	4822 530 70123
30	retaining ring 4 mm	4822 530 70124
31	retaining ring 5 mm	4822 530 70125
32	retaining ring 6 mm	4822 530 70126
33	retaining ring 8 mm	4822 530 70166
34	spring washer 4,1x7,1x0,9 mm	4822 530 80127
35	spring washer 3,1x5,7x0,8 mm	4822 530 80146
36	washer 2,6 mm	4822 530 80183
37	lock washer 3,2 mm	4822 530 80185
38	washer 3,2x8x0,5 mm	4822 532 10332
39	washer 4,2x7x0,1 mm	5322 532 10466
40	washer 3,2x8x0,1 mm	4822 532 10479
41	washer 5,1x15x1,5 mm	4822 532 10634
42	lock washer 3mm	4822 532 10668
43	washer 3,2x8x0,3 mm	4822 532 10704
44	washer 4,3x8x0,5 mm	5322 532 14061
45	washer 2,7x6,5x0,5 mm	4822 532 14464
46	washer 5,3x10x1 mm	5322 532 24282
47	washer PVC 5,2x9x0,5 mm	4822 532 50301
48	washer PVC 3,2x7x0,5 mm	4822 532 50477
49	washer PVC 4,2x7x0,5 mm	4822 532 51005
50	clamping spring	4822 492 62058

CABINET PARTS

100	lense	4822 450 60142
101	cassettelift cover N1700	4822 443 60563
101	cassettelift cover N1702	4822 443 60634
102	push button N1700	4822 410 21835
102	push button N1702	4822 410 22124
103	cover N1700	4822 443 60565
103	cover N1702	4822 443 60636
104	push button N1700	4822 410 21843
104	push button from 837 N1700	4822 410 22007
104	push button N1702	4822 410 22125
105	slide piece N1700	4822 411 60531
105	slide piece N1702	4822 410 60642
106	compression spring	4822 492 51179
106	compression spring from 837	4822 492 51223
107	front frame N1700	4822 443 50261
107	front frame from 837 N1700	4822 443 50279
107	front frame N1702	4822 443 50303

108	push button 4 N1700	4822 410 21764
108	push button 4 N1702	4822 410 22132
109	push button 3 N1700	4822 410 21763
109	push button 3 N1702	4822 410 22131
110	push button 2 N1700	4822 410 21762
110	push button 2 N1702	4822 410 22129
111	push button 1 N1700	4822 410 21761
111	push button 1 N1702	4822 410 22128
112	push button 5 N1700	4822 410 21765
112	push button 5 N1702	4822 410 22133
113	push button 6 N1700	4822 410 21766
113	push button 6 N1702	4822 410 22134
114	push button 7 N1700	4822 410 21767
114	push button 7 N1702	4822 410 22136
115	push button 8 N1700	4822 410 21768
115	push button 8 N1702	4822 410 22135
116	panel 31 with switches	4822 210 20268
117	washer	4822 466 80665
118	casing N1700	4822 443 50265
118	casing N1702	4822 443 50301
119	foot	4822 462 40306
120	bottom plate	4822 443 50247
121	compression spring	4822 492 51178
122	push button N1700	4822 410 21837
122	push button N1702	4822 410 22127
123	push button N1700	4822 410 21836
123	push button N1702	4822 410 22126
124	cover N1700	4822 443 60564
124	cover N1702	4822 443 60635
125	lense	4822 381 10451
126	slide piece N1700	4822 411 60529
126	slide piece N1702	4822 411 60641
127	screw	4822 502 11345
128	pin	4822 535 91065
129	program selector N1700	4822 218 20096
129	program selector N1702	4822 218 20112
130	blanking disc	5822 532 60623

CHASSIS PARTS

150	reel disc.	4822 528 10311
151	set of spacer rings	4822 310 30414
152	disc	4822 532 10715
153	brake block	4822 466 40118
154	distance piece	4822 403 51006
155	pulley	4822 528 60104
156	driving belt	4822 358 30152
157	pivot bearing	4822 535 91043
158	idler wheel	4822 528 90256
159	reel disc	4822 528 10318
160	pin	4822 535 91055
161	lever	4822 403 51005
162	pivot bearing	4822 462 70126
163	washer	4822 532 10698
164	roller	4822 532 10701
165	bush	4822 532 10702
166	washer	4822 532 20643
167	tape guide	4822 532 20646
168	pressure spring	4822 492 51214
169	tape guide	4822 532 20645
170	washer	4822 532 10662
171	spring	4822 492 40634
172	bush	4822 532 20657
173	washer	4822 532 10697
174	pulley	4822 528 90255
175	headdisc belt	4822 358 20032
176	pulley	4822 528 80628
177	pulley	4822 528 80669
178	ball	4822 520 40037
179	spring	4822 492 62059
180	motor plate	4822 403 50922
181	screening cap	4822 443 60521
182	grommet	4822 443 40105

LIST OF ELECTRICAL PARTS

Transistors

2N2219	5322 130 40496
2N3055	5322 130 40132
BC327	4822 130 40854
BC337	4822 130 40855
BC416C	4822 130 41102
BC546	4822 130 41001
BC547	5322 130 44257
BC547C	4822 130 44503
BC548	4822 130 40938
BC548B	4822 130 40937
BC548C	5322 130 44196
BC549	4822 130 40964
BC549C	5322 130 44264
BC557	5322 130 44256
BC558	4822 130 40941
BC558B	5322 130 44197
BC637	4822 140 41041
BD136	5322 130 40712
BD140	5322 130 40824
BD227	4822 130 40972
BD228	4822 130 40919
BD437	4822 130 40982
BF245B	4822 130 41024
BF494	5322 130 44195
BF495	4822 130 40947
BFW11	5322 130 40408
BSX20	5322 130 40417

Diodes

BAV20	5322 130 34189
BAW62	5322 130 30613
BY126	5322 130 30192
BY164	5322 130 30414
BY206	4822 130 30839
BY225	4822 130 30917
BY226	4822 130 41119
BZX75C2V1	5322 130 34049
BZX75C3V6	5322 130 30765
BZX79C6V2	5322 130 30766
BZX79C15	5322 130 34281
RGP10G	4822 130 31067
TLR4020	4822 130 30958
TLV150	4822 130 30927

Integrated circuits

IC101	μA 723CA	5322 209 84655
IC102	CD4027AE	5322 209 85117
IC103	CD4001AE	5322 209 14045
IC104	CD4001AE	5322 209 14045
IC321	C2536 N1700	4822 209 80319
IC321	C2858 N1702	4822 209 80487
IC322	CD4011AE N1700	5322 209 14046
IC322	CD4070AE N1700	5322 209 14073
IC322	HEF4081BP N1702	5322 209 14054
IC323	CD4011AE	5322 209 14046
IC323	CD4023AE	5322 209 14065

Crystals

KT501	4,43 MHz	4822 242 70147
KT502	8,86 MHz	4822 242 70252

Delay lines

TD501	635 n. sec for /00	4822 320 40045
TD501	465 n. sec for /15,/43, /45 and /65	4822 157 50887
TD701	DL60	4822 157 50864

Motors

M1	head disc motor	4822 361 20137
M2	tape transport motor	4822 361 20137
M3	threading motor	4822 361 20143
M4	friction motor	4822 361 20139

Fuses

VL1	124 C ⁰	4822 252 20017
VL101	3,15 AT	4822 253 30027
VL102	4 AT	4822 253 30038
VL501	0,315 A	4822 253 20012

Relays

RE1	4822 281 50049
RE101	4822 280 80434
RE102	4822 281 50053
RE901	4822 280 60365
RE902	4822 280 60365

Switches

SK8	4822 276 10633
SK9	4822 271 30188
SK10	4822 271 30188
SK11	4822 271 30188
SK12	4822 271 30188
SK13	4822 271 30188
SK14	4822 271 30189
SK15	4822 278 90371
SK17	4822 271 30188
SK201	4822 276 30237
SK202	4822 276 30237
SK321	4822 410 21844
SK322	4822 410 21844
SK323	4822 277 20236
SK341	SK348 4822 277 20228

Plugholder + plugs

BU1	appliance inlet	4822 265 20169
BU2		4822 267 30084
BU3		4822 265 10021
	measuring in panel 21	4822 267 50211
	3-pole socket	4822 265 30121
	4-pole socket	4822 265 30119
	5-pole socket	4822 267 40247
	6-pole socket	4822 265 30117
	7-pole socket	4822 265 40119
	3-pole plug	4822 266 30071
	4-pole plug	4822 266 30072
	5-pole plug	4822 266 30075
	6-pole plug	4822 266 30073
	7-pole plug	4822 266 40057
	socket for units	4822 267 50189
	socket for U505-507-731	4822 267 50196
	IC socket 14 pins	5322 255 44214
	IC socket 16 pins	5322 255 44111

Lamp

LA1	12 V/100 mA	5322 134 40014
-----	-------------	----------------

Heads

K3-4	audio/sync. head	4822 249 10093
K3-4	audio/sync. head till WD02	4822 249 10098
K5	erase head	4822 249 40065
K6	servo head	4822 249 20025
K7	servo head	4822 249 20025

Units

U219	headservo	4822 210 20221
U228	lock-in circuit	4822 210 20279
U230	tapeservo	4822 210 20258
U236	saw-tooth generator	4822 210 20257
U237	tape sync. unit	4822 210 20252
U505	I.F. amplifier /00/45	4822 210 20201
U505	I.F. amplifier /15/43/65	4822 210 20225
U506	detector /00/45	4822 210 20202

V-8c, N1700, N1702

U506	detector /15/43/65	4822 210 20223
U507	A.G.C. /00	4822 210 20203
U507	A.G.C. /15/43/45/65	4822 210 20259
U508	audio automatic tuning /00/45	4822 210 20204
U508	audio automatic tuning /15/43/65	4822 210 20226
U512E	562 k Hz oscillator	4822 210 20208
U513E	reference	4822 210 20209
U514	chroma filter	4822 210 20253
U515	chroma oscillator	4822 210 20254
U531	signal preparation	4822 210 20283
U532	562 kHz oscillator	4822 210 20246
U533	reference	4822 210 20245
U537	AGC/00 from 747	4822 210 20262
U539	sound	4822 210 20243
U539	sound from 817	4822 210 20292
U551	modulator /00/45	4822 210 20271
U551	modulator /00/45 from 817	4822 216 90448
U551	modulator /15/43/65	4822 210 20272
U551	modulator /15/43/65 from 817	4822 216 90449
U552	broad band for /00/15 and /43	4822 216 90416
U552	broad band aerial amp. for /45	4822 216 90437
U553	tuner for /00/15 and /65	4822 210 40136
U553	tuner ELC2004 for /00	4822 210 40159
U553	tuner for /43	4822 210 40148
U553	tuner for /45	4822 210 40155
U702	FM-processing	4822 210 20248
U731	FM modulator	4822 210 20247
U732	Fm processing	4822 210 20248
U734	FM demodulator	4822 210 20249

Coils

T1	mains transformer	4822 146 80081
S6		4822 157 50871
S201		4822 158 10224
S202		4822 158 10224
S203		4822 158 10224
S401		4822 158 10224
S402		4822 158 10224
S403		4822 158 10224
S404		4822 158 10224
S405		4822 158 10224
S406		4822 158 10224
S407		4822 158 10224
S501		4822 157 30192
S502		4822 157 50624
S503		4822 156 10431
S504	/00 and /45	4822 156 30547
S504	/15,/43 and /65	4822 156 30548
S505	/00 and /45	4822 156 60076
S505	/15,/43 and /65	4822 156 30436
S506		4822 156 20495
S507		4822 156 40504
S508		4822 156 20765
S701		4822 156 10431
S702		4822 156 10431
S703		4822 156 10429
S704		4822 156 10428
S705		4822 156 20619
S706		4822 156 20619
S901		4822 156 50745
S902		4822 156 60081

Resistors

R84	100Ω	4822 111 30343
R75	2,2 kΩ	4822 100 10029
R95	2,2 kΩ	4822 105 10117
R101	1,2 Ω	4822 113 80201
R105	6,8 k Ω	5322 116 54012
R106	10 k Ω	5322 116 54619
R109	10 k Ω	5322 116 54619
R111	12 k Ω	5322 116 50572
R112	12 k Ω	5322 116 50572

R113	2 k Ω	5322 116 54572
R149	22 k Ω	5322 116 54003
R150	1 Ω	4822 111 30215
R162	1 Ω	4822 111 30215
R341	67 k Ω	4822 101 90075
R348		
R401	100 Ω	4822 110 63081
R402	100 Ω	4822 110 63081
R506	10 Ω	4822 111 30405
R526	10 Ω	4822 111 30405
R701	1 Ω	4822 111 30215
R710	4,7 k Ω	4822 100 10025
R711	1 k Ω	4822 100 10021
R901	82 Ω	5322 116 54462
R906	390 Ω	5322 116 54006
R909	22 Ω	5322 116 50983
R910	22 Ω	5322 116 50983

Capacitors

C1	2200 μF - 63 V	5322 124 74072
C102	150 nF - 100 V	4822 121 40491
C103	2200 μF - 40 V	4822 124 70252
C104	3300 μF - 25 V	5322 124 74045
C107	1000 μF - 63 V	4822 124 70215
C115	150 nF - 100 V	4822 121 40491
C116	4,7 μF - 16 V	5322 124 14064
C124	1 μF - 35 V	5322 124 14075
C125	10 nF - 65 V	4822 122 30043
C127	68 μF - 6,3 V	5322 124 14079
C132	22 nF - 50 V	4822 122 30103
C201	100 nF - 100 V	4822 121 41161
C202	100 nF - 100 V	4822 121 41161
C203	100 nF - 100 V	4822 121 41161
C204	100 nF - 100 V	4822 121 41161
C205	10 nF - 250 V	4822 121 41134
C206	2,7 nF - 100 V	4822 122 30057
C501	2,2 μF - 63 V	4822 124 20584
C509	22 pF	4822 125 50045
C512	22 nF - 400 V	4822 121 40488
C515	10 μF - 63 V	4822 124 20496
C519	4,7 μF - 63 V	5322 124 20593
C523	22 pF	4822 125 50045
C527	4,7 nF	4822 122 31125
C528	82 pF	4822 122 31078
C701	68 μF - 16 V	5322 124 20377
C710	820 pF - 125 V	5322 121 54072
C711	820 pF - 125 V	5322 121 54072

Panels

panel 31	4822 210 20268
panel 32 N1700	4822 210 20269
panel 32 N1702	4822 210 20295
panel 91	4822 210 20261

Cables

mainsflex for /00	4822 321 10084
mainsflex for /00 from 824	4822 321 10183
mainsflex for /15 and /65	4822 323 30002
mainsflex for /15 and /65 from 824	4822 321 10184
mainsflex for /43	4822 321 10058
mainsflex for /43 from 824	4822 321 10185

N1004/11

Pos. 1	coaxial plug	4822 264 30104
Pos. 2	coaxial lead (per metre)	4822 322 10026
Pos. 3	coaxial plug	4822 266 10034

N1008/00

Pos. 1	plug 6 pole - 240°	4822 264 40099
Pos. 2	lead	4822 322 40035
Pos. 3	plug 6 pole - 240°	4822 264 40099

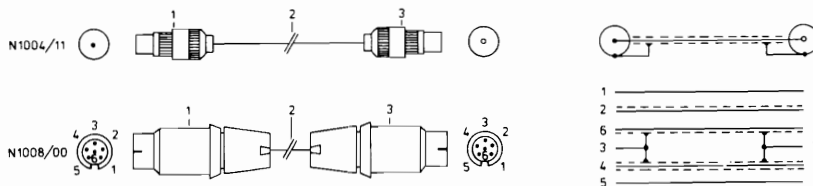

VI ADDITIONAL SERVICE INFORMATION

VI A Modifications in diagram A

VI B Modifications in diagram B

VI C Modifications in diagram C

VI D Modifications in diagram D

VI E Modifications in the mechanical section

MODIFICATIONS IN CIRCUIT DIAGRAM A

Intr. date	Modification	Reason
1 Production start	U531 has been replaced with 4822 210 20283	The VCR identification pulse is deleted
2	The luminance writing voltage has been changed into 0,8 Vpp	See new adjusting procedure
3	C511 changed from 10 nF into 12 nF	Improved bias adjustment
4 728	R522 changed from 820 Ω into 1,5 kΩ R524 changed from 820 Ω into 560 Ω	Greater brightness-difference on reception of a luminance signal with or without chrominance
WD01	New panels 7 and 11	
WD02	New pressure roller bracket 239	
5 738	TS905 changed from BF495 into BF494 TS906 changed from BF494 into BF495	Amplification adaption
6 WD03/747 for /00 only.	<p>Channel selector U553 type ELC2000S has been replaced with type ELC2004. As a result, a number of components has been cancelled or added. Also the AGC-unit U507 has been changed. The new number for the AGC-unit is U537. <i>Changed:</i> U553 (channel selector) from ELC2000S to ELC2004, code 4822 210 40159. U507 (AGC-unit) to U537, code 4822 210 20262. U506 from .3 to .4. Only version .4 may be used in combination with channel selector ELC2004. Under the existing code 4822 210 20202 the .4 version will be supplied in future. The .4 version may also be used in combination with channel selector ELC2000S.</p> <p><i>Cancelled:</i> D502 - BAW62 D503 - BAW62 D504 - BAW62 D505 - BAW62 D507 - BAW62 R510 - 4,7 kΩ R512 - 47 kΩ R513 - 4,7 kΩ</p> <p><i>Added:</i> R344 - 1 Ω (1/8 W - 5%) replaces D505. R543 - 560 Ω (1/8 W - 5%) replaces D507 C527 - 4,7 nF code 4822 122 31125 has been fitted between junction R509, R511 and mass. Parallel circuit S508, C528 (82 pF)-has been fitted between point 16 of U506 and point 17 of U537. Code S508: 4822 156 20765 Code C528: 4822 122 31078</p> <p><i>Remark:</i> The last 3 additions and the change of U506 prevent oscillations in the HF-section. The solder bridges SP503, SP504 and SP506 have been closed.</p>	Production of channel selector ELC2000S has stopped.

	Intr. date	Modification	Reason
7	748	U531 has been changed from 3103 128 2139.2 to .3.	Improved clamping of the luminance signal.
8	WD04/ for /00 WD03/ for /45 802	<p>U508 has been changed from 3103 128 2075.4 to .5. The VHF/UHF amplification change-over will be effected in the output amplifier in future. As a result of this change, the following changes had to be carried out to the main signal print and to the supply print.</p> <p>On print 51 - R509 cancelled - R508 changed from 12 kΩ to 1 Ω - 1/8 W - 5% .</p> <p>On print 11 - R120 changed from 10 kΩ to 6.2 kΩ - 1/8 W - 5% .</p> <p>Service supplies For the time being, under the existing service codenumber 4822 210 20204 the version 3103 128 2075.4 will be supplied. An accompanying letter states what to do if the .5 version is replaced with .4. In future, the .5 version will become available. Also this version will be supplied under code 4822 210 20204. An accompanying letter will state what to do if the .4 version is replaced with .5.</p>	Stabilizing the zero adjustment of the PHAFT control voltage.
	WD03/ for /15/43 /65 802	<p>U508 has been changed from 3103 128 2094.2 to .3. For a description of this change, see changed U508 for /00/45 above.</p> <p>Service supplies For the time being, under the existing service codenumber 4822 210 20226, the version 3103 128 2094.2 will be supplied. An accompanying letter states what to do if the .3 version is replaced with .2. In future, the .3 version will become available. Also this version will be supplied under code 4822 210 20226. An accompanying letter will state what to do if the .2 version is replaced with .3.</p>	
9	809	<p>R528 changed from 2,7 kΩ to 1,2 kΩ R539 changed from 47 kΩ to 120 kΩ R540 changed from 4,7 kΩ to 3,9 kΩ</p>	Adaptation to the tolerances of KT502
	WD05 for /00 WD04 for /15/43/45/65	New lower drum	
		<p>C517 should be 56 pF instead of 68 pF C910 should be 6,8 pF instead of 10 pF</p>	Correction

	Intr. date	Modification	Reason
	WD06 for /00 WD05 for /15/43/45/65	Improved tape end stop	
10	WD07 for /00 WD06 for /45 817	<p>The UHF-modulator U551 has been replaced with a version in which the audio pre-emphasis filter is built-in in the modulator. The service code of this modulator is: 4822 216 90448.</p> <p>In the old situation the pre-emphasis operation of the audio signal, which was supplied to the UHF-modulator, was effected in U539. Because of the introduction of the new UHF-modulator, U539 has been changed. The service code of the new version is: 4822 210 20292.</p> <p>The old UHF-modulator U551 with service code 4822 210 20271 is not interchangeable with the new one, nor is the old U539 (4822 210 20243) interchangeable with the new one. Pairwise, however, the old U551 and U539 are interchangeable. The old version of the U551 and U539 continue to be available.</p>	Wider universal use of the new UHF-modulator U551 (with pre-emphasis filter).
	WD06 for /15/43/65 817	<p>For a description of the change, see above description for the /00. The service code of the UHF-modulator with pre-emphasis filter is 4822 216 90449. The service code of the new version of the U539 is identical to that of the /00 version, viz. 4822 210 20292.</p>	
	WD08 for /00 WD07 for /15/43/45/65	New mains flex	
11	832	U512E has been changed from 3103 128 2079.5 to .6	Improved adjustment of the burstgate.
	WD09 for /00/20 WD08 for /15/43/45/65	Changed print track panel 11	
	WD10 for /00/20 WD09 for /15/43/45/65	Drum changed	

	Intr. date	Modification	Reason
12	851	U731 changed from 3103 128 2117.3 to .4. In addition: The FM-sweep adjustment has been changed from 3.3-4.8 MHz to 3.45-4.95 MHz.	Improving the resolution of the luminance signal on playback.
13	902	U732 (FM-playback processor) has been replaced with U702 In addition: U732 and U702 are interchangeable. The service codenumber of U702 is the same as that for U732: 4822 210 20248. In future, only U702 will be supplied.	The two ICs in U732 have been replaced with one IC in U702
14	901	R530 on print 51 has been changed from 3 k Ω to 2.7 k Ω - 1/8 W - 5 % .	As a result, the amplitude of the luminance signal at the output of the luminance detector is adapted to the amplitude of the luminance playback signal.

	Date of introduction	Changes	Reason
1	WD00	<p>From start production the following changes have been introduced in the signal section of the N1702 as compared with the last version of the signal section of the N1700: U512E and U513E have been replaced with U532 and U533 Service code U532 - 4822 210 20246 Service code U533 - 4822 210 20245</p> <p>As a result, R526 on print 51 was deleted and D516, D517 have been added. For the adapted circuit diagram A, see additional page IV-5-III. For the adapted component layout of print 51, see additional page IV-5-IV. For the adapted adjustment instruction, see replacement pages III-5b, III-6b and III-9b.</p> <p><i>Remark:</i> U512E and U532 are not interchangeable. U513E and U533 are not interchangeable. Pairwise exchange of U512E/U513E with U532/U533 is possible. Then also R526 and D516, D517 have to be deleted resp. added. U512E and U513E continue to be available.</p>	<p>Improved quality U533 has a built-in test pattern generator. This test pattern may be used to tune the TV-set connected to the VCR modulator frequency (first time tuning). The test pattern is switched on when:</p> <ul style="list-style-type: none"> . set switched on . no cassette inserted . the set is in recording position

MODIFICATIONS IN CIRCUIT DIAGRAM B

Intr. date	Modification	Reason
1 Production start	C205 changed from 10 nF into 18 nF TS203 changed from BC548 into BC548C U237 changed from .4 to .5	More amplification of sync. signal of K4
2	Added R217 (1.8k)	Now it is possible to switch off the set, after it has been switched-on by the electronic timer
3	Zero point adjustment of the tracking has been changed	See new adjusting procedure

MODIFICATIONS IN CIRCUIT DIAGRAM C

Intr. date	Modification	Reason
1 Production start	D86 changed from BAW62 into BY206 D87 changed from BAW62 into BY206 D116 changed from BAW62 into BY206	BY206 gives a better resistance to interference pulses
2	R115 has been replaced with a safety resistor. Code number: 4822 111 30409	Safety
3	Added: R168 (1.5k)	Protection against interference pulses
4	Added: C2 (100 nF)	Suppression of motor interferences
5	Added: C3 (47 nF) C4 (47 nF)	Suppression of motor interferences
6	C120 changed from 3,3 μ F into 2,2 μ F	Delay time has been reduced to 30 sec. so that the possibility become smaller that thin tapes get damaged
7	C121 changed from 100 nF into 220 nF	Less chance of switching off upon threading in
8	Added: D90 (BY206)	Protection
9	Adjusting of the control of M4 has been modified	See new adjusting procedure
10 WD01/734	Introduction of new panels 7 and 11 See new circuit and wiring diagrams	In this way it is avoided that upon threading in the head disc will be braked so that the set will be switched-off and tape damages will be prevented
WD02	New pressure roller bracket 239	
11 745	The IC-holders on panel 11 have been deleted.	Poor quality of the holders. Remark: These holders are being used again from production code 802.
WD03 for /00	New channel selector	
WD04 for /00 WD03 for /15/43/45/65	Changed U508	
12 808	Cancelled C131 (10 nF)	Superfluous
WD05 for /00 WD04 for /15/43/45/65	New lower drum	
13 811	Added: R2 - 10 k Ω (1/8 W - 5 %) between point 8 of SK8 and point 1 of SK11. Is fitted on SK8.	Protection against drop-out of IC's.
14 812	Added: R110 - 2,7 k Ω (1/8 W - 5 %) between the + of C103 and points 11 and 12 of IC101. Is fitted on the print track side. Added: D115 (BAW62) between the + of C104 and point 13 of IC101. Is fitted on the print track side with the cathode connected to the + of C104.	Protection against drop-out of IC101

	Intr. date	Modification	Reason
15	WD06 for /00 WD05 for /15/43/45/65 814	R123 has been replaced with D131 (BZX75/C3V6 - 5322 130 30765). The cathode is connected to junction R124-C116. R124 changed from 10 kΩ to 2,7 kΩ R135 changed from 220 kΩ to 100 kΩ Added: R123 - 220 kΩ (1/8 W - 5 %) between the +11 supply voltage and junction R134,C119. Is fitted on the print track side.	Improving the reliability of switch-off at the end of the tape for tapes that have a low electrical resistance of the oxyd-layer.
		TS77 should be BC546 instead of BC548. TS103 should be BC547C instead of BC547. TS106 should be BC337 instead of BC637. Code number BC547C: 4822 130 44503.	Correction
16	815	C129 changed from 10 nF into 1 nF C130 changed from 10 nF into 1 nF	More reliable functioning of IC102.
	WD07 for /00 WD06 for /15/43/45/65	Changed U551 and U539.	
	WD08 for /00 WD07 for /15/43/45/65	New mains flex.	
17	828	R158 has been replaced with a jumper.	The current limitation by R158 is superfluous.
18	828	The polarity of C127 has been interchanged The +pole has been connected to point 3 of IC101.	Only during interferences there is reverse tension over C127.
19	WD09 for /00 WD08 for /15/43/45/65 835	The print track of panei 11 has been changed. R140 changed from 1,5 kΩ into 470 Ω Added: D132 - RGP10G C135 - 68 μF R169 - 10 kΩ R170 - 10 kΩ R171 - 1 kΩ Code RGP10G: 4822 130 31067	Adaptation of the print track to changes already effected. Protection of IC102
20	838	R110 has been changed from 2.7 kΩ to 2.2 kΩ Added: R172 - 15 kΩ (1/8 W - 5 %) between point 10 of IC101 and mass; is fitted on the copper side of the print. R173 - 10 kΩ (1/8 W - 5 %) between point 10 of IC103 and D119.	Extra protection of IC101

MODIFICATIONS IN CIRCUIT DIAGRAM D

	Intr.date	Modification	Reason
1	Production start	R324 changed from 270, into 100K	Improved control of the electronic timer
	WD01	New panels 7 and 11	
	WD02	New pressure roller bracket 239	
	WD03	New channel selector	
2	747	S321 has been replaced with a diode (BY206) The anode of this diode is connected to D14.	This provides that the supply voltage for the clock does not momentarily become too low as a result from the increase in load when the set is switched-on by the clock, so that the clock would become non-activated and would not switch-on the set.
	WD04 for /00 WD03 for /15/43/45/65	Changed U508	
	WD05 for /00 WD04 for /15/43/45/65	New lower drum	
	WD06 for /00 WD05 for /15/43/45/65	Improved tape end stop	
	WD07 for /00 WD06 for /15/43/45/65	Changed U551 and U539	
3	817	Panel 32 has been changed completely. See the new circuit and wiring diagrams. Panel 32 continues to be available under the existing codenumber. Code IC322 (CD4070AE): 5322 209 14073 Code IC323 (CD4023AE): 5322 209 14065	Introduction of a colon between the hours and the minutes.

VI D-2, N1702

	Date of introduction	Changes	Reason
1	WD00	From start production of the N1702, the clock print panel has been changed completely. Code new print: 4822 210 20295. Code new IC321 (C2858) 4822 209 80487 Code new IC322 (HEF4081BP) 5322 209 14054 For the adapted circuit and wiring diagrams of the new print see pages IV-11-III and IV-11-IV.	<ol style="list-style-type: none"> 1. The maximum switch-on time via the timer has been increased from 2 to 3 hours 2. The number of days that a recording can be pre-programmed via the timer has been increased from 3 to 9 days.

MODIFICATIONS IN THE MECHANICAL SECTION

	Intr. date	Modification	Reason
1	Production start	Lubricating of capstan bearing has been changed Upon replacing the capstan bearing it is sufficient to lubricate this bearing with Shell spirax EP90, code number 5322 390 10019.	This lubrication is better suitable for a low number of revolutions
2		Several mechanical adjustments have been modified	See new mechanical adjustments
3		Added: Reinforcement plate 549 This plate is fitted with 6 screws 16 and the two cassette roller spindles	Reinforcement of the chassis Tape-path more stable
4		The hinge bracket of panel 11 has been changed. Strip 501 (mains flex relief) is now fitted with one screw 4 in the said bracket and one self-tapper 21 in the bottom	The chassis is fixed to the bottom at 3 points, reducing the chance of chassis distortion.
5	729	The mounting of the erase head K5 has been changed. Remark: This modification has been included in the service manual	Improved mounting of erase head K5, so that the audio track will be erased better
	WD01	New panels 7 and 11	
6	735	Cover plate 103 has been provided with snap locks on either corner at the front	Improved cover fixing
7	WD02/736	Pressure roller lever 239 has been modified Remark: With the exception of the adjusting screw 11 for the parallel adjustment of the pressure roller this modification has already been included in the service manual. For sets up to WD02 the complete old lever is available under code number 4822 403 40083. The code number of the old audio/sync. head is 4822 249 10098.	Improved tape-path. The tape does no longer jam in the upper reel of the cassette. Remark: For the adjustment of this lever see the new mechanical adjusting procedure When the playback key is pressed, the underside of the pressure roller spindle may catch behind the cassette holder, with the result that tape transport does not take place. If this occurs, the opening for the pressure roller in the cassette holder must be slightly filed out.
8	743	The bush of the capstan bearing has been turned 20° with respect to the mounting plate.	This provides that, when the cassette holder is closed, it does not catch behind the plastic pins in the capstan bearing. <i>Remark:</i> Up to production code 743 these pins have been cut-off.
9	743	The mounting of the plastic disc on which the 2 small gears turn, on the spindle of transmission 286 , has been improved	The chance that this disc turns on is smaller. <i>Remark:</i> The improved version can be seen from the grey or rose tinted colour.

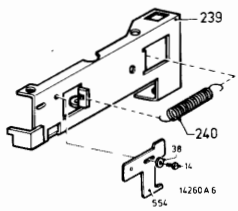
Intr. date	Modification	Reason
10 745	The mass contact of the metal pin on the lower drum, on which tape guide 169 is fitted, has been improved, by using electrically conductive silver lacquer at the underside of the lower drum. This silver lacquer, in 100 gram packing, is available under code 4822 390 40064.	Improving the mass contact of SK16 <i>Remark:</i> It is recommendable to check the mass contact of SK16 in sets up to production code 745 (value must be < 500 Ω). After taking out the lower drum and demounting gear ring 185, some lacquer, if necessary, can be applied between the metal pin on which the tape guide 169 is fitted and the lower drum.
11 746	Pin 525 that operates SK17 has become 1 mm longer.	Improving the operating reliability of SK17.
WD03	New channel selector	
12 749	The material of ring 215 has been changed from rubber to plastic, also the upper edge has been bevelled. Under the existing code 4822 532 51038 the improved ring is supplied.	Improved mounting. Less chance of oil leakage from the capstan bearing. Less chance for the cassette holder to catch behind this ring.
13	Tape guide L of the lower drum, with the tape continuously touching cam O of the drum ruler, has to be turned another 135° clockwise.	<i>Correction:</i> Please correct this on page III-18 under chapter 2.4.10.
WD04 for /00 WD03 for /15/43/45/65	Changed U508.	
14 802	Carbon brush 202 is impregnated in a special oil.	Less noise
15 WD05 for /00 WD04 for /15/43/45/65 809	The ruler on the lower drum has been changed Codenummer of lower drum with changed ruler: 4822 528 80683. The stop of bracket 245 has been changed. The changed bracket can also be used for old apparatus. The thickness of the drum stop 548 has been changed to 3 mms.	The angle at which the tape is wound round the lower drum has been decreased by 1,5°, diminishing the chance of overlapping.
16 814	Added: adjustment plate 554 on bracket 239, fitted with ring 38 and screw 14. 	By means of this plate (that can be shifted with respect to bracket 239) the distance capstan-pressure roller can be adjusted. For this adjustment see page III-13.
	Code number of casing 118 is 4822 528 70198.	Correction.

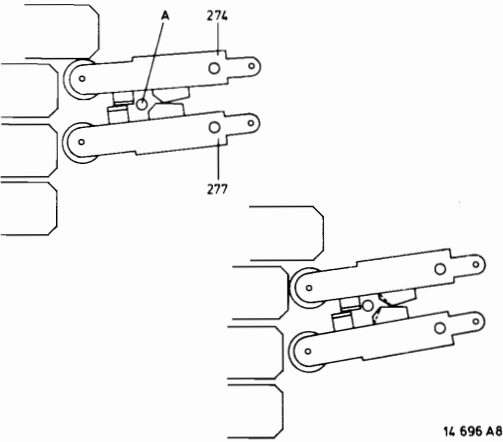
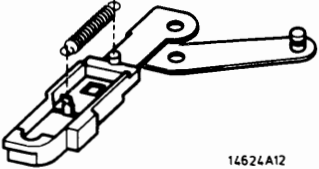
	Intr.date	Modification	Reason
17	803	<p>The angle of the nose of brackets 274 and 277 has been changed.</p> 	<p>Pin A of strip 273 now does not catch behind these brackets any more. This occurs when the set is switched off in wind or rewind position while the start key is held. The lower drum is threaded-out indeed, but SK 12 is not switched back then. The threading motor remains activated whilst it is blocked. It is recommended to replace the brackets 274 and 277 in apparatus up to code 803 with the changed brackets, which are available under the existing codenumbers.</p>
	WD06 for /00 WD05 for /15/43/45/65	Improved stop at the end of the tape	
18	814	<p>Bracket 245 has been changed completely. The new bracket may replace the old one and is available under code 4822 403 51062.</p>	<p>More reliable functioning. The new bracket does not jump over the information pins on the lower drum any more.</p> 
	WD07 for /00 WD06 for /15/43/45/65	Changed U551 and U539	
19	817	<p>The gap width of the audio head has been changed from 1,7 to 2 μm. The changed audio/sync head is supplied under the existing codenumber.</p> <p>Spacer 229A has been changed and a special ring added between this spacer and the mounting plate of the audio/sync head. Under codenumber 4822 532 10749 spacer and ring are supplied. Consequently, also the mounting plate of the audio/sync head has been changed. Because the changed audio/sync head is supplied under the existing codenumber, spacer 229A has to be replaced with the new spacer with ring, when this head is exchanged in old apparatus.</p>	<p>The frequency range has been improved and less distortion of the audio signal.</p> <p>Improvement of the height adjustment of the audio/sync head. Under code 4822 249 10093 the new audio/sync. head is supplied, packed together with the new distance piece and the added ring, so that this assembly can be used for both the new and the old version apparatus. A note providing this information is likewise co-packed.</p>
		<p>Because the capstan bearing cannot stand too great a pressure force of the pressure roller, this pressure force is factory-adjusted at 1700 ± 300 g. For the modified adjustment, see the new adjustment instruction.</p>	

	Intr. date	Modification	Reason
20	824	Control and fitting of SK9 and SK10 have been changed. Codenumbers: Slide 226A: 4822 278 90339 Tension spring 225A: 4822 492 30611	To improve the reliable operation of SK9 and SK10.
21	WD08 for /00 WD07 for /15/43/45/65 824	The soldered joint of the mains flex has been changed into a plug connection. For this, the bracket in which panel II hinges, has been fitted with an adapter and a mains input socket (BU1). This socket is accessible via a hole in housing 118. Under the existing code the changed housing is supplied. The hole for the mains plug is covered by a removable plate, so that this housing can be used for either old or new apparatus. Codenumbers: Adapter: 4822 263 50065 BU1: 4822 265 20169 Mains flex for /00: 4822 321 10183 Mains flex for /15: 4822 321 10184 Mains flex for /43: 4822 321 10185	
22	829	The following plug holders have been replaced with plug holders fitted with a locking tag: On panel 7 plug holders E5 and E6 On panel 11 plug holders P1,P2,P3 and P4 On panel 21 plug holders A1,A2,A3,A5 A6 and A7 On panel 51 plug holders K5,L1,L2 and L5 . The other plug holders remain unchanged, because they are hard to access. Remark: Because only plug holders with locking tags will be supplied, it is recommended to break off the tag if one of the plug holders that are hard to access has to be replaced. Plug holder S1 on panel 40 has been replaced with a 4-pole version with locking tag. Point S14 is connected to mass.	Better locking of the plugs Short-circuit prevention
	WD09 for /00 WD08 for /15/43/45/65	New print track of panel 11.	
23	837	The dimensions of the ON/OFF key 104 have been replaced. The hole in front 107 has been adapted. Also the pressure force of spring 106 has been increased. Codenumbers: New ON/OFF key 104 4822 410 22007 New front 107 4822 443 50279 New pressure spring 106 4822 492 51223	Reduces the chance for the ON/OFF key to stick in the front.

	Intr. date	Modification	Reason						
24	WD10 for /00 WD09 for /15/43/45/65 847	<p>The lower drum 184 has been changed as follows:</p> <ul style="list-style-type: none"> - The angle of the catch pin (pin N in Fig. III-15) has been changed from 90° to 90° 15' - The plastic auxiliary guide at the tape inlet on the lower drum has been deleted - Between tape guide 167 and pressure spring 168 a plastic ring has been added (code 4822 532 60094) - The two pressure springs underneath the tape guides 167 and 169 have been changed (code 4822 492 51022). The changed lower drum is supplied under code 4822 528 80726. <p>The lower drum is fitted 0,2 mm higher by using an extra ring (3,2x8x0,2 mm) underneath guide roller 164 (code 4822 532 10722).</p> <p>The erase head must be adjusted at right angles. Corrections are possible by bending bracket 522.</p> <p style="text-align: center;">Survey of the lower drums fitted so far:</p> <table border="1" style="margin-left: auto; margin-right: auto;"> <tr> <td style="text-align: center; width: 150px;">4822 528 80677</td> <td style="text-align: center; width: 150px;">4822 528 80683 (changed ruler)</td> <td style="text-align: center; width: 150px;">4822 528 80726 (changed catch pin)</td> </tr> <tr> <td style="text-align: center;">↑ Production start</td> <td style="text-align: center;">↑ WD04 for /00 WD03 for /15/43/45/65</td> <td style="text-align: center;">↑ WD10 for /00 WD09 for /15/43/45/65</td> </tr> </table>	4822 528 80677	4822 528 80683 (changed ruler)	4822 528 80726 (changed catch pin)	↑ Production start	↑ WD04 for /00 WD03 for /15/43/45/65	↑ WD10 for /00 WD09 for /15/43/45/65	Improving the tape path
4822 528 80677	4822 528 80683 (changed ruler)	4822 528 80726 (changed catch pin)							
↑ Production start	↑ WD04 for /00 WD03 for /15/43/45/65	↑ WD10 for /00 WD09 for /15/43/45/65							
25	850	All plug connections on the prints are fitted with locking tags. See also point 22 on page VI E-4.							
26	902	The coupling between the threading motor and worm on plate 297A has been improved. The assembly plate with worm + motor is available under code 4822 361 30105. This assembly can be used for both the old and the new sets.	Improved coupling between threading motor and worm						

VI E-6, N1702

	Date of introduction	Changes	Reason																																																																																	
1	WD00	<p>From start production the N1702 cabinet and tape-deck have been changed with respect to the N1700 as follows:</p> <p>Cabinet section</p> <p>Listed below, please find the new code numbers of the changed cabinet parts</p> <table border="0"> <tr><td>Pos. 101</td><td>Cassette holder cover</td><td>4822 443 60634</td></tr> <tr><td>Pos. 102</td><td>Knob</td><td>4822 410 22124</td></tr> <tr><td>Pos. 103</td><td>Cover plate</td><td>4822 443 60636</td></tr> <tr><td>Pos. 104</td><td>Push button</td><td>4822 410 22125</td></tr> <tr><td>Pos. 105</td><td>Knob</td><td>4822 410 60642</td></tr> <tr><td>Pos. 107</td><td>Window</td><td>4822 443 50303</td></tr> <tr><td>Pos. 108</td><td>Push button 4</td><td>4822 410 22132</td></tr> <tr><td>Pos. 109</td><td>Push button 3</td><td>4822 410 22131</td></tr> <tr><td>Pos. 110</td><td>Push button 2</td><td>4822 410 22129</td></tr> <tr><td>Pos. 111</td><td>Push button 1</td><td>4822 410 22128</td></tr> <tr><td>Pos. 112</td><td>Push button 5</td><td>4822 410 22133</td></tr> <tr><td>Pos. 113</td><td>Push button 6</td><td>4822 410 22134</td></tr> <tr><td>Pos. 114</td><td>Push button 7</td><td>4822 410 22136</td></tr> <tr><td>Pos. 115</td><td>Push button 8</td><td>4822 410 22135</td></tr> <tr><td>Pos. 118</td><td>Casing</td><td>4822 443 50301</td></tr> <tr><td>Pos. 122</td><td>Push button</td><td>4822 410 22127</td></tr> <tr><td>Pos. 123</td><td>Push button</td><td>4822 410 22126</td></tr> <tr><td>Pos. 124</td><td>Strip</td><td>4822 443 60635</td></tr> <tr><td>Pos. 126</td><td>Knob</td><td>4822 411 60641</td></tr> <tr><td>Pos. 129</td><td>Tuning unit</td><td>4822 218 20112</td></tr> </table> <p>Tape-deck</p> <p>Listed below, please find the new code numbers of the changed tape-deck parts</p> <table border="0"> <tr><td>Pos. 183</td><td>Head disc</td><td>4822 691 20098</td></tr> <tr><td>Pos. 198</td><td>Counter</td><td>4822 349 50101</td></tr> <tr><td>Pos. 247</td><td>Push button "stop"</td><td>4822 410 22123</td></tr> <tr><td>Pos. 248</td><td>Push button "rew"</td><td>4822 410 22118</td></tr> <tr><td>Pos. 249</td><td>Push button "start"</td><td>4822 410 22117</td></tr> <tr><td>Pos. 250</td><td>Push button "wind"</td><td>4822 410 22121</td></tr> <tr><td>Pos. 251</td><td>Push button "rec"</td><td>4822 410 22122</td></tr> </table> <p>For the adapted mechanical and electrical parts lists, see the enclosed replacement pages V-5c, V-6c, V-7c and V-8c.</p>	Pos. 101	Cassette holder cover	4822 443 60634	Pos. 102	Knob	4822 410 22124	Pos. 103	Cover plate	4822 443 60636	Pos. 104	Push button	4822 410 22125	Pos. 105	Knob	4822 410 60642	Pos. 107	Window	4822 443 50303	Pos. 108	Push button 4	4822 410 22132	Pos. 109	Push button 3	4822 410 22131	Pos. 110	Push button 2	4822 410 22129	Pos. 111	Push button 1	4822 410 22128	Pos. 112	Push button 5	4822 410 22133	Pos. 113	Push button 6	4822 410 22134	Pos. 114	Push button 7	4822 410 22136	Pos. 115	Push button 8	4822 410 22135	Pos. 118	Casing	4822 443 50301	Pos. 122	Push button	4822 410 22127	Pos. 123	Push button	4822 410 22126	Pos. 124	Strip	4822 443 60635	Pos. 126	Knob	4822 411 60641	Pos. 129	Tuning unit	4822 218 20112	Pos. 183	Head disc	4822 691 20098	Pos. 198	Counter	4822 349 50101	Pos. 247	Push button "stop"	4822 410 22123	Pos. 248	Push button "rew"	4822 410 22118	Pos. 249	Push button "start"	4822 410 22117	Pos. 250	Push button "wind"	4822 410 22121	Pos. 251	Push button "rec"	4822 410 22122	<p>Changed colour</p> <p>4-figure</p> <p>Changed colour</p>
Pos. 101	Cassette holder cover	4822 443 60634																																																																																		
Pos. 102	Knob	4822 410 22124																																																																																		
Pos. 103	Cover plate	4822 443 60636																																																																																		
Pos. 104	Push button	4822 410 22125																																																																																		
Pos. 105	Knob	4822 410 60642																																																																																		
Pos. 107	Window	4822 443 50303																																																																																		
Pos. 108	Push button 4	4822 410 22132																																																																																		
Pos. 109	Push button 3	4822 410 22131																																																																																		
Pos. 110	Push button 2	4822 410 22129																																																																																		
Pos. 111	Push button 1	4822 410 22128																																																																																		
Pos. 112	Push button 5	4822 410 22133																																																																																		
Pos. 113	Push button 6	4822 410 22134																																																																																		
Pos. 114	Push button 7	4822 410 22136																																																																																		
Pos. 115	Push button 8	4822 410 22135																																																																																		
Pos. 118	Casing	4822 443 50301																																																																																		
Pos. 122	Push button	4822 410 22127																																																																																		
Pos. 123	Push button	4822 410 22126																																																																																		
Pos. 124	Strip	4822 443 60635																																																																																		
Pos. 126	Knob	4822 411 60641																																																																																		
Pos. 129	Tuning unit	4822 218 20112																																																																																		
Pos. 183	Head disc	4822 691 20098																																																																																		
Pos. 198	Counter	4822 349 50101																																																																																		
Pos. 247	Push button "stop"	4822 410 22123																																																																																		
Pos. 248	Push button "rew"	4822 410 22118																																																																																		
Pos. 249	Push button "start"	4822 410 22117																																																																																		
Pos. 250	Push button "wind"	4822 410 22121																																																																																		
Pos. 251	Push button "rec"	4822 410 22122																																																																																		

VII. REPAIR METHOD

Contents

	Page
Repair method	
Introduction	VII-2
Checking procedure	VII-3...VII-5
Repair procedure	VII-6...VII-15

INTRODUCTION

With this repair method the faults occurring most, can be quickly located.

The method is split up in two parts, viz. a checking and a repair procedure.

First, the VCR is connected as indicated in the heading of the checking procedure. We take it that the CTV-receiver is well-adapted for playback of VCR-signals.

The VCR must be checked in the sequence indicated by the numbers I...VII of the checking procedure. If no fault is found for a number, then the next point can be checked immediately.

Listed under each number are the symptoms of the fault followed by the number of the repair procedure to which is referred. In some cases, there is direct reference to the faulty circuit.

The fault that symptoms cannot be detected during a quick inspection are listed under point VII.

General remarks

- It is advisable to clean the tape-deck of the VCR properly before each repair.
 - If e.g. 11U514 → 1U731 is indicated, then check the circuit or the connection between these points.
 - If e.g. it says measure on C-TS1, then the DC-voltage must be measured on this point.
 - If the voltage measured does not deviate more than approx. 20% from the value stated, it can be considered good.
- The voltages are measured with a multimeter of 40,000 Ohm/V.

Practical hints

The logical circuits of clock and safety circuits on the supply print are made up of the ICs IC102, 103, 104, 321, 322 and 323, using MOS-technique (Metal Oxide Silicon).

Because of the high input impedance these ICs are very sensitive to static discharges at non-closed inputs and outputs.

Therefore, pay special attention to the following points:

On replacement:

- . Do not touch the ICs with fingers
- On fault-finding or replacement, first read the instructions packed with the ICs.
- . Do not switch-on the set if one of the ICs has been removed, otherwise the ICs still present may be damaged.

On measuring:

- . Connect the chassis to earth
 - . Measuring instruments must be properly earthed.
 - . Connect the soldering iron via an isolating transformer and connect to earth.
- When measuring voltages at the various IC-outputs, set the measuring ranges of the meter not lower than approx. 15 Volts.

Principal print panels with components

Panel 7 - friction

nrs. 70...99
plugs E

Panel 11 - supply

nrs. 100...199
plugs P

Panel 21 - servo

nrs. 200...299
plugs A and B

Panel 32 - timer

nrs. 320...399
plugs D

Panel 51 - front end

nrs. 500...599
plugs K and L

Panel 71 - video

nrs. 700...799
plugs F

Panel 91 - head amplifier

nrs. 900...999

CHECKING PROCEDURE

- . Connect aerial or colour pattern generator to VCR
- . Connect VCR to CTV
- . Connect VCR to the mains (do not switch on)

I CHECK THAT THE CLOCK IS IN WORKING ORDER

Does not work:

1a

II TUNE CTV TO AERIAL/GENERATOR SIGNAL

Weak or no picture:

J-U552 → + 1,
U552

III SWITCH ON VCR

Check threading-in and threading-out

- . Threads out shortly after threading-in
- . Does not thread in
- . Does not thread out
- . Tape is not wound or rewound correctly
- . Threads in too quickly
- . Counter and reel disc continue rotating in position "off" without cassette
- . Tape rotates in position "stop"
- . Does not thread out automatically after about 30 sec.
- . LA1 does not light up after threading in

3-a

3-c

Check the threading-out circuit as shown in Fig. VII-1

3-d

TS1, TS113, IC101

D122, TS76, TS77

Check the friction in reel disc items 159 and 153

3-b

1-SK12 → plug P57 → D112 → RE102

THREADING OUT

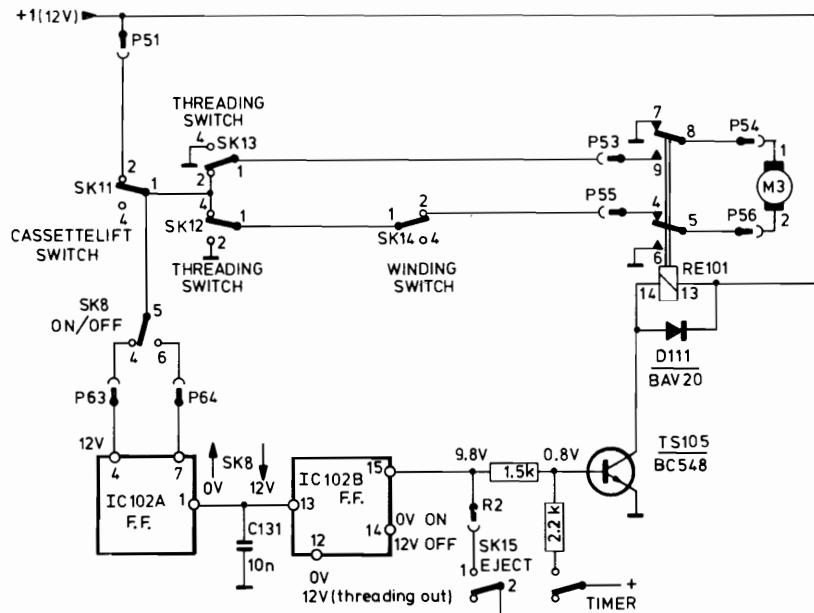

Fig. VII-1

IV INSERTING A PRE MODULATED CASSETTE VCR IN POSITION PLAYBACK TUNING CTV TO VCR

- . Picture and sound normal
- . Weak or no picture - Weak or no sound
- . Weak or no picture - Normal sound
- . Poor or no sync - Normal sound
- . Normal picture - Weak, poor or no sound
- . Weak, wrong or no colour
- . Dropouts in picture (disturbing dots or stripes)
- . Tracking does not function properly
- . Unstable picture
- . Unstable sound (wow)
- . Start key does not remain pressed

- . Start key is not released after switching off
- . Threads out immediately after pressing start key
- . Cassette does not rotate
- . Switches off always after about 30 sec.

V VCR IN POSITION "STOP"

Check that VCR has been properly tuned (CTV has already been tuned)

- . Normal picture and sound
- . Weak or no picture - Weak or no sound
- . Weak or no picture - Normal sound
- . Normal picture - Weak, poor or no sound
- . Weak or no colour
- . Phaft does not work properly

*** Note:**

To avoid that during adjusting or measuring, the VCR always switches off after about 30 sec. press the wind key or the rewind key (without cassette).

see V

4-a

4-b

4-b

4-c

4-d

4-e

4-f

4-f

4-f

TS107, TS108, R125, C119
Adjustment of relay S6

TS107, TS108, D121, Relay S6

3-a

1-SK12 → Plug P57 → D112 → RE102

Plug P33 → Plug A12 → 1-SK202, IC103.

see VI

5-a

5-b

5-c

U506, TS503

5-d

VI MAKE A RECORDING AND CHECK THE RESULT

- . No sound during recording
- . Does not record colour
- . Does not record
- . Picture and/or sound unstable
- . Threads out immediately

VII MISCELLANEOUS

- . Switches off during playback and recording at beginning of tape by the stop foil
- . Does not switch off at beginning or end of tape
- . Switches off during playback and/or fast winding after about 30 sec.
- . Does not switch off automatically after about 30 sec in position "stop"
- . Does not switch off when heads drum and/or tape transport are blocked
- . Tape rotates in position "stop"
- . Keys are not released after switching off
- . Cassette rotates too slowly or does not rotate at all during fast winding
- . Does not switch on/off with clock
- . When there is a mains failure, the keys are not released
- . The tape is not wound or rewound correctly

VL501, SK17
+3 circuit (plug K52)

U514, 11U514 → 1U731

U731, Plug A74 (+3A), plugs L55, F45, F24
TS901....TS903

U237, TS508
Erase head K5 (about 1 Ω)
Plug K21 → K5

C526, C901,
+3 circuit short-circuited ?

D116, C116, R148, R164
C128, IC103

2-b

8-IC103 → SK14, IC103

3-b

12-IC104 → C-TS111, 14-IC104 → + 1A
R129, C123, R165, IC104.

Check the friction in reel disc, items 159 and 153

TS107, TS108, D121, Relay S6

3-e

2-a

TS77, C1, R84

3-d

REPAIR PROCEDURE

1a Clock does not work

. Do not switch on VCR

. Measure on plug P51 (+ 1 on supply print)

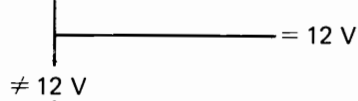

. Measure on C-TS1 (about 22 V)



. Measure on E-TS1 (12 V)

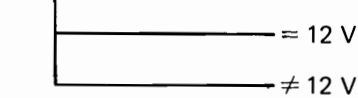

R150 → Plug P74 → plug D12 (40 V ~)

Check the clock print

VL102, D102, VL1, T1

E-TS1 → plug P72 → plug D14

VL101, D101

TS1, TS113, IC101

D110, D113, + 1 or + 10 circuit short-circuited?

2a Does not switch on/off with the clock

. Switch off VCR

. Measure on 14-IC102 on supply print (11 V)

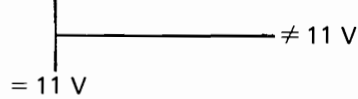

. Press start key (Do not switch on VCR)

. Measure on plug D15 of clock print (11 V)

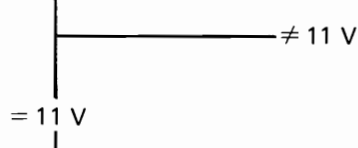

. Switch on VCR

. Measure on plug D13 (0,8 V)

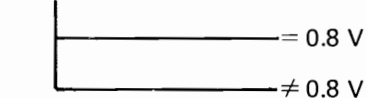

IC102

Plug D15 → plug P73 → Plug P31 → 12/13 SK202 → 14-IC102

Check the clock print

Plug D13 → Plug P75 → B TS105

2b Does not switch off at beginning or end of tape by the stop foil

. VCR in position "wind"

. Measure on plug P66 (SK16) on supply p.c. board

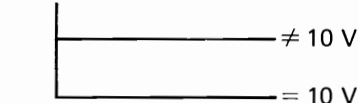

3-IC103 → plug P66, 8-IC103 → SK14, IC103

Plug P66 → SK16, C128, R121

3a VCR switches off shortly after threading-in

. To avoid that the VCR always switches off, connect 3-IC104 (A-D121) to chassis (after repair remove this connection)

. Switch on VCR

. Measure on 3-U219 (15 V) and on 3-U230 (9 V)

1. 3U219 = 15 V and 3U230 ≠ 9 V

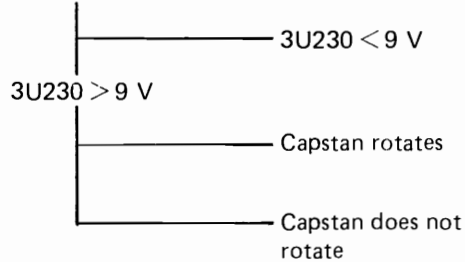

U230, TS202

TS109, TS110, K7 (140 Ω)

Driving belt M2, 3U230 → M2

2. 3U219 ≠ 15 V and 3U230 = 9 V

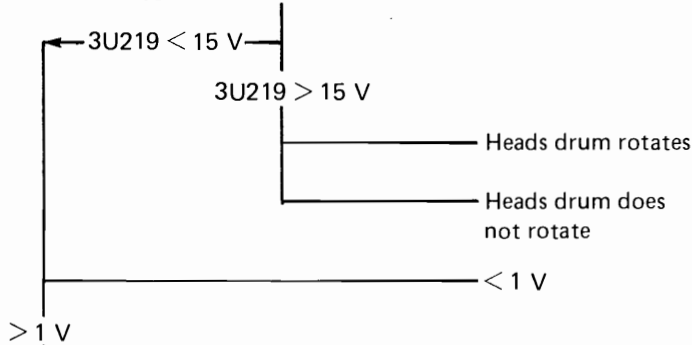

U236, K6 (140 Ω)

15U236 → K6 → **⬇**

Driving belt M1, 3U219 → M1

U219, TS201

. Measure on 10U236 (8.5 V) and on 11U236 (6.2 V)

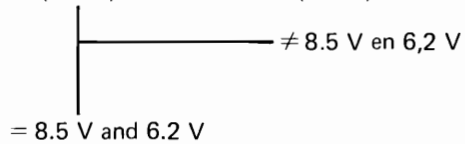

U236, U513, 12 U236 → 9U513, 10U513 → +1A

. Measure on 7U237, with tracking control to the left 8 V and to the right 1,3 V

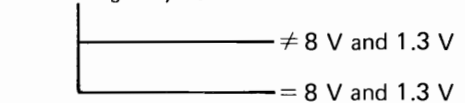

U237

U219, U228 TS201

3. 3U219 ≠ 15 V and 3U230 ≠ 9 V

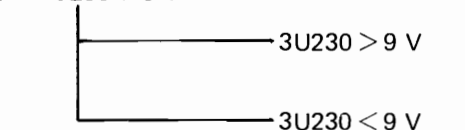

Plug B21 → P92 (+1A), Plug B25 → S12

Plug B23 → P93 (+7), Plug B27 → P94 (+10) +7 circuit short-circuited?

4. 3U219 = 15 V and 3U230 = 9 V

IC104, TS111, Plug P41 → A61

3b VCR does not switch off automatically after about 30 sec. in position "stop"

- . VCR in position "stop"
- . Measure on 10-IC103 (12 V)



IC103
R127, C120, R148, D121,
IC104

3c Does not thread in

- . Check that relay RE101 is attracted for a moment only when the VCR is switched on

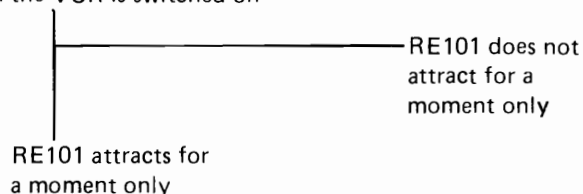

Check the threading-in circuit (see Fig. VII-2)

- . Connect 3-IC104 (A-D121) to chassis (remove connection after repair)

- . Switch on VCR

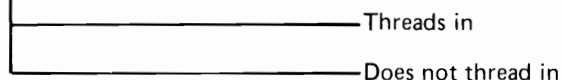

D106, D119, D123, D125, IC104
D112, IC102,

THREADING

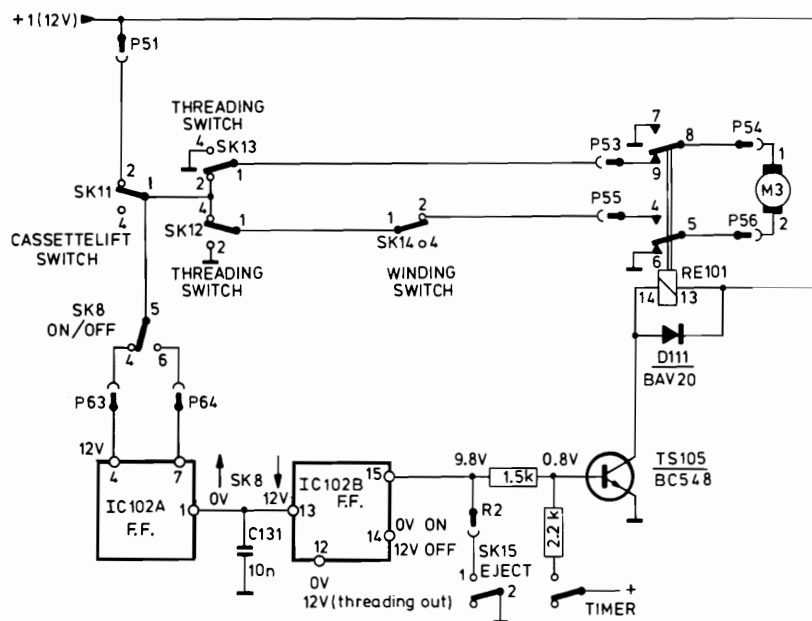

Fig. VII-2

3d Tape is not wound or rewound correctly

- . Remove the cassette
- . Check that the little reel disc rotates in position "stop" and in position "play back"

1. Does not rotate in position "Playback"; rotates in position "stop"

2. Does not rotate in position "stop"; rotates in position "Playback"

3. Does not rotate in either position

4. Rotates in both positions

- . Slide a cassette in to the VCR
- . VCR in position "Playback"
- . Measure the voltage across the friction motor M4 (3.6 V)

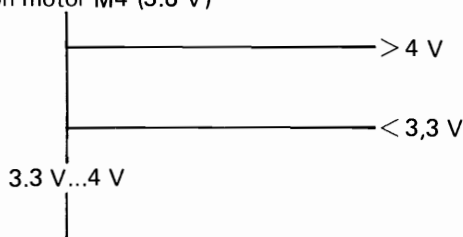

- . Check control for circuit TS106, TS112 of brake relay S1.
- The control should be such that attracting and deenergising is in conformity with diagram Fig. VII-3.
- The brake can be seen through the window of the cassette holder when the cassette has been removed.

D74 → plug P43 → plug P33 →
Plug A12 → 2/3 - SK202 (+1A)

D73 → SK10 → SK9 →
Plug A34 → 4/5 SK202 (+1A)

Driving belt M4,
TS71, TS72, R86, D82
Friction motor M4

TS71, TS72, TS75
Adjust R75

TS71, TS72, TS78
Adjust R75

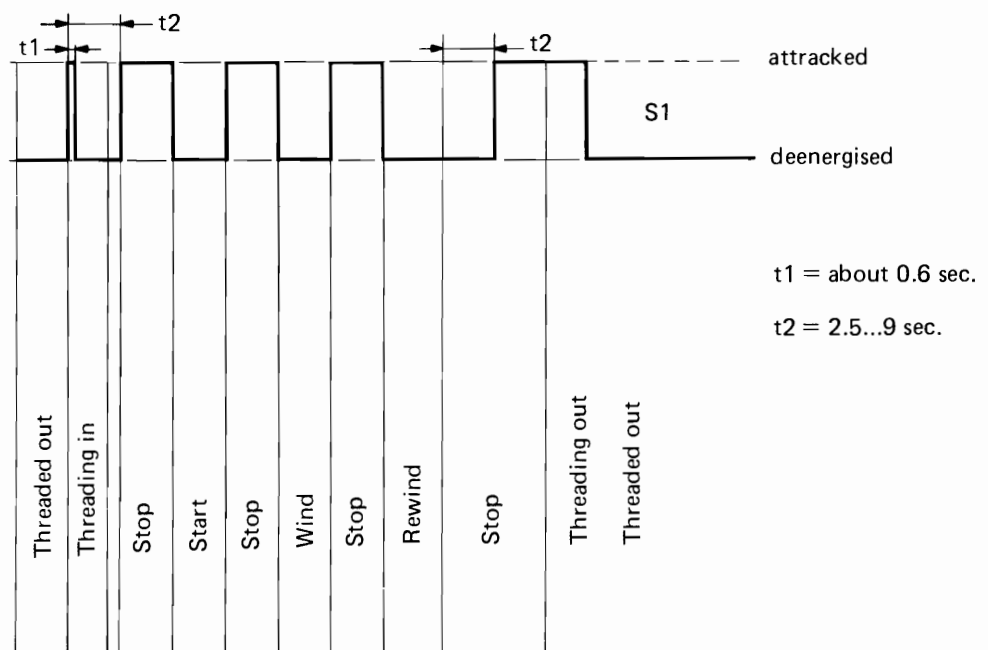
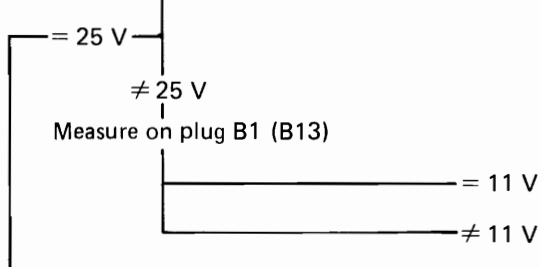

Fig. VII-3

3e Cassette does not rotate or rotates too slowly during fast winding

. VCR in position "Wind"

. Measure on 2U230 (25 V)



. VCR in position "Rewind"

. Measure on 2U230 (25 V)

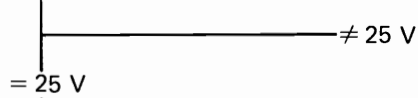

. VCR in position "Wind"

. Measure the voltage across friction motor M4 (7 V)

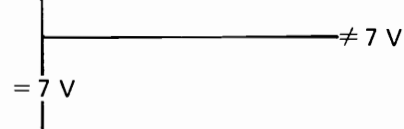

Check the driving mechanism with idlerwheel item 158

TS204, TS205

Plug B1 → plug E41 → SK9

SK10 → plug E41 (12 V)

R77, D77
TS71-TS72

4a "PB" Weak or no picture - Weak or no sound

- . VCR in position "playback" or "stop"
- . Measure on E-U551 (12 V)

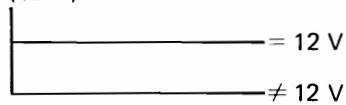

U551
 TS501, TS502
 1-SK12 → Plug P57 → D112 → RE102

4b "PB" Weak or no picture - Normal sound or Poor or no sync.

- . VCR in position "stop"
- . Tune VCR to colour signal until the luminance and chrominance indicating LED lights up 100% *

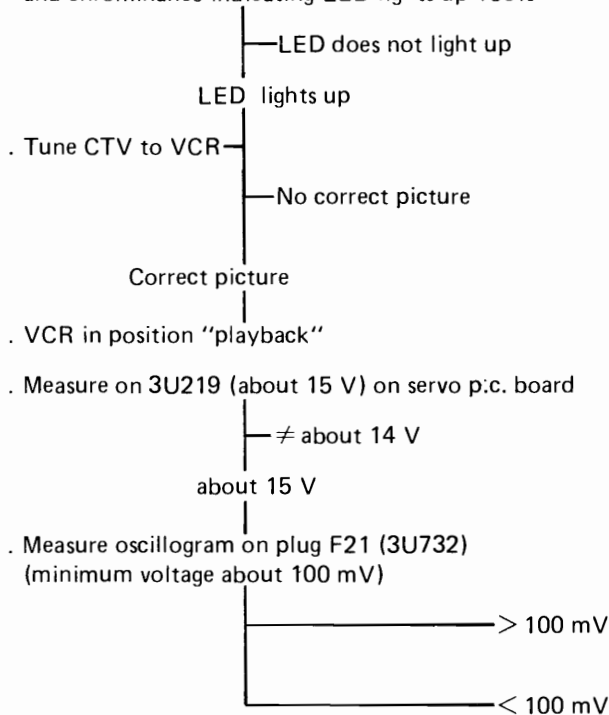

U513E

 U531, 5U531 → 11U531
 U551

 See 4-f (servo)

 U732, U734
 R701 (+6A), 1U734 → 17U507
 Headdrum (K1/K2)
 Plug A73 (+ 6)
 TS904....TS906

* Note:
 The LED lights up 30% when the set is tuned to a black/white signal and 100% when the set is tuned to a colour signal.

4c "PB" Normal picture - Weak, poor or no sound

- . VCR in position "stop"
- . Tune VCR to input signal

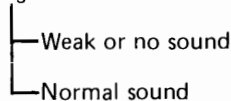

U509, U551

 U510, K3 (about 120 Ω),
 3U510 → K3

4d "P.B." Weak, wrong or no colour (Black-white picture correct)

. VCR in position "stop"

. Tune CTV to VCR

Colour correct

Colour not correct

. Keep the programme key depressed and tune the VCR to a colour signal until the LED for the luminance and chrominance indication lights up 100% *

LED lights up 30%

U515, U514, U512E, U513E

LED lights up 100%

. Tune CTV to VCR

Colour not correct

U514, U515

Colour correct

. VCR in position "Playback"

. Measure on plug L33 (E-TS703) 5 V

≠ 5 V

TS702, TS703, plugs L33, F33

= 5 V

. Measure on plug K44 (16U515) 8,5 V

≠ 8.5 V

TS504

= 8.5 V

U515, U512E

* Note:

The LED lights up 30% when the set is tuned to a black/white signal, and 100% when the set is tuned to a colour signal.

4e Dropouts in picture

. First check that the tape path is clean

U732, U734, TD701

4f "P.B." Picture and/or sound instable

- . First clean the VCR
- . VCR in position "Playback" with pre-modulated cassette
- . Measure on 3U230 (about 9 V)

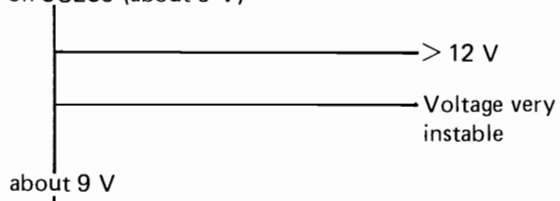

U230, plugs A32, P22
 U237, U230, 6U237 → Plug A62,
 16U513 → R119

- . Measure on 3U219 (about 15 V)



U219

- . Measure oscillogram on 4U237 (8,5 V)

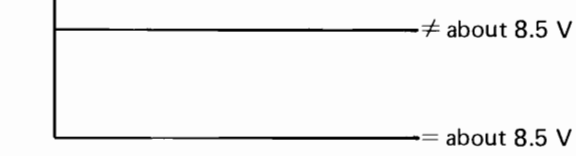

U237, K4 (about 100 Ω)
 3U237 → plug A41.
 Check the adjustment of K4
 U237, U236, U230

5a "Stop" Weak or no picture - Weak or no sound

- . Remove aerial from VCR
- . Remove cassette
- . Channel selector in position "U" (UHF)
- . VCR in position "wind" or "rewind" (to avoid that VCR switches off after about 30 sec).
- . Measure on plug L52 (16U506) 3.6 V

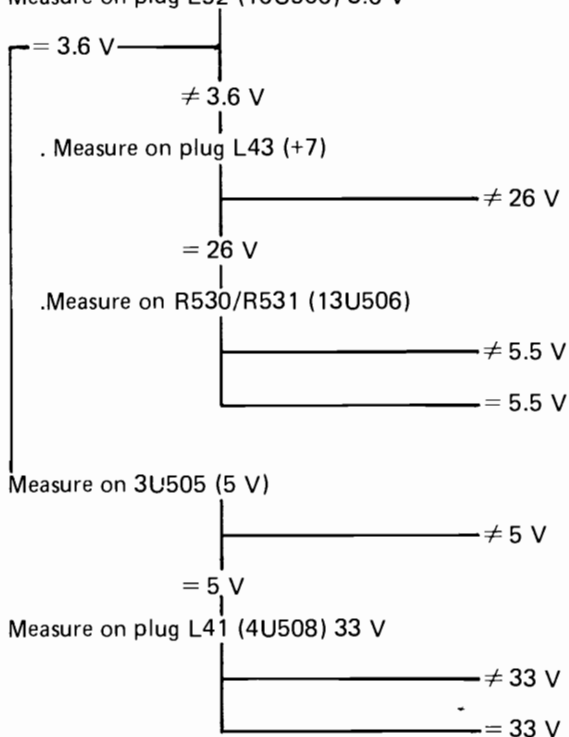

Plug L43 → Plug P87 (+7)

U506, C514

U506, U507
U553 (see voltage table)

U507

Plug L41 → TS104 (+8), U508

U506,
U553 (see voltage table)

Voltage table

Tuner U553

	VHF I	VHF III	UHF
1	2.5 V 3.5 V	2.5 V 3.5 V	0.5 V
2	0-30 V	0-30 V	0-30 V
3	-3 V	11 V	11 V
4	11	10	0.6
5	12	11	0.6
6	12	12	12
8	0	0	0
10	0.5	0.5	11
12	0.5	0.5	11
13	0.4	0.4	2.5 4

5b "Stop" Weak or no picture - Normal sound

- . Replace U506
- If no result:
- . Remove aerial from VCR
- . VCR in position "stop"
- . Measure on 3U505 (5 V)

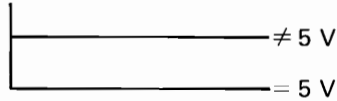

U507, R531
U505, U553

5c "Stop" Normal picture - Weak, poor or no sound

- . VCR in position "stop"
- . Measure on 17U508 (2.5 V)

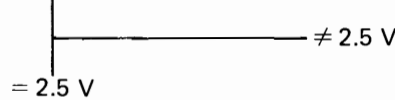

U508, R542

- . Measure on 2U506 (9 V)

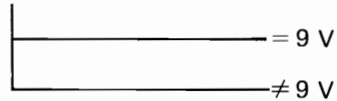

U509, U508
U506

5d Phaft does not work properly

1. No normal sound
2. Normal sound

- . Measure on plug L42 (-9)

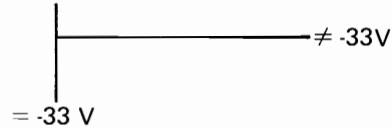

Plug L42 → -9 (D109),
U508

- . Measure on plug L41 (+8)

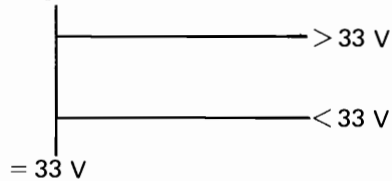

Check TS104 for C-E short-circuit before
replacing U508

Plug L41 → + 8 (TS104), U508

- . Keep the programm button
depressed and measure on E-TS507

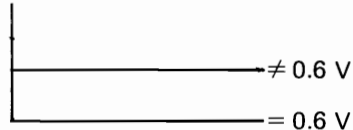

TS507
U508, D501

Service Information

1979-03-15

VIDEO CASSETTE RECORDER
N1700, N1702

VR79-9

Already published: VR77-19, VR77-20, VR77-24,
VR78-02, VR78-11, VR78-20,
VR78-28, VR78-32, VR78-33,
VR79-05

In this Service Information all service data relative to the differences between the N1702 and the N1700 are published. These data are contained in resp. additional and replacement pages for the N1700 Service documentation. By adding these pages to the N1700 Service documentation, a combined N1700/N1702 Service documentation is obtained.

CONTENTS

Replacement pages	Front page
	III-5b
	III-6b
	III-9b
	V-5c
	V-6c
	V-7c
	V-8c
Additional pages	IV-5-III
	IV-5-IV
	IV-11-III
	IV-11-IV
	VI A-5
	VI D-2
	VI E-6

Service Information

	1978-08-01
VIDEO CASSETTE RECORDER N1700/00/43/45	
	VR78-32

Already published: VR77-19, VR77-21, VR77-24,
VR78-02, VR78-11, VR78-20,
VR78-28

Reeds verschenen: VR77-19, VR77-21, VR77-25,
VR78-03, VR78-12, VR78-21,
VR78-29

In the N1700/00/43/45 the aerial amplifier remains switched-on in playback position. As a result, the aerial signal on the aerial input of the recorder is also present on the aerial output in playback position. In certain cases, especially when the recorder is connected to a central aerial system, this may cause interferences in the picture on playback. This may be cured by switching-off the built-in aerial amplifier in playback position. For this purpose, print 51 has to be changed as follows (see also Fig. 1):

- Replace wire connection (A) with a diode D513 (BAW62 - 4822 130 30613).
- Add diode D514 (BAW62 - 4822 130 30613)
- Open solder bridge SP512

Bij de N1700/43/45 blijft de antenne versterker in de positie weergave ingeschakeld. Hierdoor is het antenne signaal op de antenne-ingang van de recorder ook in de positie weergave op de antenne-uitgang aanwezig. In bepaalde gevallen, speciaal wanneer de recorder op een centraal antenne-systeem is aangesloten, kan dit bij weergave aanleiding geven tot storingen in het beeld. Deze storingen kunnen voorkomen worden door in de positie weergave de ingebouwde antenne versterker uit te schakelen.

Hierbeneden en in Fig. 1 is aangegeven hoe printplaat 51 hiervoor gewijzigd moet worden.

- Draadverbinding (A) vervangen door een diode D513 (BAW62, 4822 130 30613).
- Toevoegen diode D514 (BAW62, 4822 130 30613)
- Soldeerbrug SP512 openen.

Paru précédemment: VR77-19, VR77-23, VR77-27,
VR78-05, VR78-14, VR78-23,
VR78-31

Bereits veröffentlicht: VR77-19, VR77-22, VR77-26,
VR78-04, VR78-13, VR78-22,
VR78-30

Sur les N1700/00/43/45 l'amplificateur d'antenne reste commuté en position reproduction. Il en résulte que le signal d'antenne sur l'entrée d'antenne de l'enregistreur est aussi présent sur la sortie d'antenne en position reproduction. Dans certains cas, surtout lorsque l'enregistreur est raccordé à un système d'antenne centrale, cela pourrait donner lieu en position reproduction à des interférences dans l'image. Ces interférences peuvent être évitées en mettant l'amplificateur d'antenne incorporé hors service dans cette position.

Ci-dessous et en Fig. 1 on trouvera comment adapter la platine 51 à cette modification:

- Remplacer le fil (A) par une diode D513 (BAW62, 4822 130 30613)
- Ajouter la diode D514 (BAW62, 4822 130 30613)
- Ouvrir le pontet SP512.

Beim N1700/00/43/45 bleibt der Antennenverstärker in Stellung Wiedergabe eingeschaltet. Demzufolge ist das Antennensignal am Antenneneingang des Recorders auch in Stellung Wiedergabe am Antennenausgang vorhanden. In bestimmten Fällen, namentlich wenn der Recorder an eine gemeinsame Antennenanlage angeschlossen ist, können bei Wiedergabe Störungen im Bild verursacht werden. Diese Störungen lassen sich vermeiden, wenn man in Stellung Wiedergabe den eingebauten Antennenverstärker ausschaltet.

Hierunter und in Abb. 1 wird gezeigt, wie Print 51 hierzu zu ändern ist.

- Drahtverbinding (A) durch Diode D513 (BAW62, 4822 130 30613) ersetzen.
- Hinzufügen: Diode D514 (BAW62, 4822 130 30613)
- Lötbrücke SP512 öffnen.

PANEL 51 N1700/00

MISC	BU2	D506	U553	T5507	D509	S505	S08	D501	U508	S504	U552	T5503	U531	S37	S05	S06	T501	S501	S03	U551	T501	S04	B03	T5502	S537	S05	K7501	V501	S506	D502	K7502	T5506	U539	U536	S32E	T5505	U534	
C					527	510	501	503	515	502	528		508	518		507	516	505	517		523	504	513	526	506	511	512	514	519	521	522				509			
R	503	505	508	544	543	501	511	520	530	506	531	502	532			542	533	536	517	518		541	540	514	516	537	539	528	528	514	521	522		525	532	524		

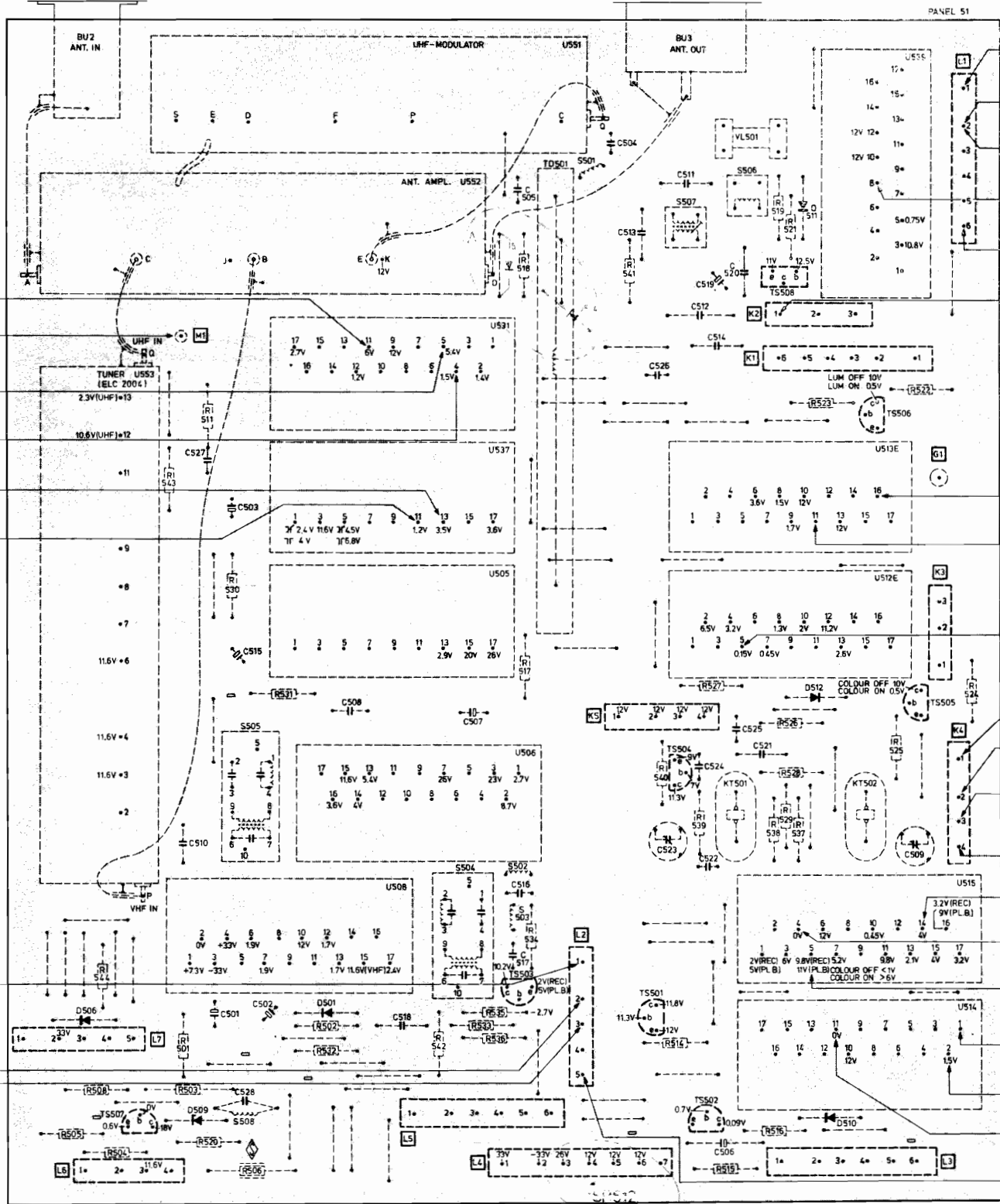

1362812

Fig. 1

Service Information



PHILIPS

1977-10-27

VIDEO CASSETTE RECORDER N1700

VR77-19

Re: Practical hints and explanation.

The logical circuits of clock and safety circuits on the supply print are made up of the ICs IC102, 103, 104, 321, 322 and 323, using MOS-technique (Metal Oxyde Silicon).

Because of the high input impedence these ICs are very sensitive to static discharges at non-closed inputs and outputs.

Therefore, pay special attention to the following points:

On replacement:

- . Do not touch the ICs with fingers
- On fault-finding or replacement, first read the instructions packed with the ICs.
- . Do not switch-on the set if one of the ICs has been removed, otherwise the ICs still present may be damaged.

On measuring:

- . Connect the chassis to earth
 - . Measuring instruments must be properly earthed.
 - . Connect the soldering iron via an isolating transformer and connect to earth.
- When measuring voltages at the various IC-outputs, set the measuring range of the meter not lower than approx. 15 Volts.

Explanation:

The Service Information Bulletins about Video Recorders consist of the yellow front page and of one or more replacement pages and/or supplementary pages.

The yellow front page surveys the supplementary pages and/or replacement pages.

Supplementary pages are denoted by a Roman figure behind the page number. If these supplementary pages are added to a chapter, these pages are numbered consecutively.

Replacement pages are denoted by a small letter behind the page number.

Example: Page V - 4 I b

- This is the replacement page of V - 4 I a.
- Page V - 4 I was the replacement page of V - 4 I
- Page V - 4 I was an additional page behind page V - 4.

Betreft: Praktische tips en toelichting.

De logische schakelingen van de klok en de beveiligings-schakelingen op de voedingsprint zijn opgebouwd met de I.C.'s IC102, 103, 104, 321, 322 en 323.

Deze I.C.'s zijn uitgevoerd in de M.O.S. techniek (Metal Oxyde Silicon).

Vanwege de hoge ingangsimpedantie zijn deze I.C.'s bij niet afgesloten in- en uitgangen zeer gevoelig voor statische ontladingen.

Let daarom vooral op onderstaande punten:

Bij vervanging:

- . Raak de I.C.'s niet met vingers aan.
- Bij foutzoeken of vervanging eerst de instructies lezen, die bij de I.C.'s worden verpakt.
- . Schakel het apparaat niet in, terwijl één van de I.C.'s is verwijderd, want dit kan de overgebleven I.C.'s beschadigen.

Bij metingen:

- . Leg het chassis aan aarde.
- . De meetinstrumenten deugdelijk aarden.
- . De soldeerbout aansluiten via een scheidingstransformator en aarden.
- . Bij spanningsmetingen op de diverse uitgangen van de I.C.'s het meetbereik van de meter niet lager dan ca. 15 V zetten.

Toelichting:

Service mededelingen betrekking hebbende op video-recorders bestaan, behalve uit het gele frontblad, uit een of meerdere vervangings- en/of toevoegingsbladen. Het gele frontblad vermeldt een opsomming van de toevoegings- en/of vervangingsbladen. Toevoegingsbladen krijgen een romeins cijfer achter het bladzijdenummer. Indien deze achter een hoofdstuk worden toegevoegd worden deze bladen doorgenummerd. Vervangingsbladen krijgen een kleine letter achter het bladzijdenummer.

Voorbeeld: blad V-4 I b

- Dit is het vervangingsblad van V-4 I a.
- blad V-4 I a was het vervangingsblad van V-4 I.
- blad V-4 I was een toevoegingsblad achter blad V-4.

Objet: Conseils pratiques et explication.

Les circuits logiques des circuits d'horloge et de sécurité sur la platine d'alimentation sont composés des IC102, 103, 104, 321, 322 et 323. Ces I.C. sont de technologie M.O.S. (Metal Oxyde Silicon).
Du fait de l'impédance d'entrée élevée ces I.C. sont très sensibles aux décharges statiques lorsque les entrées et les sorties ne sont pas bloquées.

En cas de remplacement:

- . Ne pas toucher les I.C. des doigts.
Lors de dépiستages ou en cas de remplacement, lire avant tout les instructions faisant partie de l'emballage de ces I.C.
- . Ne pas mettre l'appareil en marche lorsque un des I.C. est ôté, ce qui pourrait abîmer les I.C. restant.

Lors de mesures:

- . Mettre le châssis à la terre.
- . Mettre convenablement les instruments de mesure à la terre.
- . Raccorder le fer à souder à travers un transformateur d'isolement et le mettre à la terre.
- . Lors de mesures de tension sur les différentes sorties des I.C. ne pas régler la gamme de mesure à moins de 15 V.

Explication:

Les Info Service traitant des magnétoscopes se composent non seulement d'une feuille de couverture jaune, mais aussi d'une ou de plusieurs feuillets, supplément et/ou de remplacement.

La feuille de couverture jaune présente une énumération des feuillets supplément et/ou de remplacement.

Les feuillets-supplément sont reconnaissables au chiffre romain figurant derrière le numéro de la page. Si ces feuillets sont ajoutés à un chapitre, la numérotation sera poursuivie.

Les feuilles de remplacement sont identifiables à la lettre minuscule figurant à la suite du numéro de la page.

Exemple: p. V-4 I b

Il s'agit de la feuille de remplacement de V-4 I a.

p. V-4 I a est la feuille de remplacement de V-4 I.

p. V-4 I est un feuillet supplément à la suite de la p. V-4.

Betr.: Praktische Hinweise + Erläuterung

Die logischen Uhrschaltungen und die Schutzschaltungen auf den Speiseprint setzen sich zusammen aus den ICs IC102, 103, 104, 321, 322 und 323. Diese ICs sind in MOS - Technik ausgeführt. (Metal Oxyde Silicon)
Wegen der hohen Eingangsimpedanz sind diese ICs bei nichtgeschlossenen Ein- und Ausgängen sehr empfindlich gegen statische Entladungen.

Bei Ersatz

- . Die ICs nicht mit den Fingern berühren.
- . Bei Fehlersuche oder Ersatz erst die Weisungen lesen, die mit den ICs mitgeliefert werden.
- . Gerät nicht einschalten, wenn eines der ICs entfernt ist, denn sonst könnten die übrigen ICs beschädigt werden.

Bei Messungen

- . Das Chassis an Erde legen
- . Die Messinstrumente einwandfrei erden.
- . Den LötKolben über einen Trenntransformator anschliessen und erden.
- . Bei Spannungsmessungen an den diversen Ausgängen der ICs ist der Messbereich des Messgeräts nicht niedriger als auf ca. 15 V zu stellen.

Erläuterung:

Service-Mitteilungen über Videorecorder bestehen - ausser der gelben Frontpagina - aus einem oder mehreren Ersatz- und/oder Ergänzungsblättern.

Die gelbe Frontpagina gibt eine Übersicht über die Ergänzungs- und/oder Zusatzblätter.

Ergänzungsblätter werden mit einer römischen Ziffer hinter der Blattnummer bezeichnet.

Wenn diese Blätter hinter einem Kapitel hinzugefügt werden, werden sie durchnummeriert.

Ersatzblätter werden mit einem kleinen Buchstaben hinter der Blattnummer bezeichnet.

Beispiel: Blatt V - 4 I b

Dies ist das Ersatzblatt von V - 4 I a

Blatt V - 4 I a war das Ersatzblatt von V - 4 I

Blatt V - 4 I war ein Zusatzblatt hinter Blatt V - 4.