

# SERVICE NOTES

## RADIO 4216A

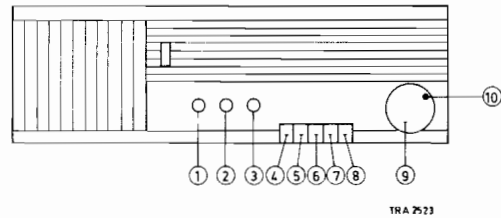

- |   |  |  |  |  |  |
|---|--|--|--|--|--|
| <p>1 Volume control<br/>Volumeregelaar<br/>Commande de volume<br/>Lautstärkeregl.<br/>Control de volumen</p> <p>2 Tone control<br/>Toonregeling<br/>Commande de tonalité<br/>Klangregler<br/>Control de tonalidad</p> <p>3 AM tuning<br/>AM-afstemming<br/>Syntonisation AM<br/>AM-Abstimmung<br/>Sintonía AM</p> | <p>R26</p> <p>R29</p> <p>C16<br/>C17</p> | <p>4 Mains switch<br/>Netschakelaar<br/>Interrupteur secteur<br/>Netzschalter<br/>Interruptor de red</p> <p>5 LW switch<br/>LG-schakelaar<br/>Commutateur GO<br/>LW-Schalter<br/>Commutador OL</p> <p>6 MW switch<br/>MG-schakelaar<br/>Commutateur PO<br/>MW-Schalter<br/>Commutador OM</p> <p>9 FM-tuning<br/>FM-afstemming<br/>Syntonisation FM<br/>FM-Abstimmung<br/>Sintonía FM</p> | <p>SK-A</p> <p>SK-L</p> <p>SK-M</p> <p>S4-S5</p> | <p>5 Record-player switch<br/>PU-schakelaar<br/>Commutateur PU<br/>TA-Schalter<br/>Commutador PU</p> <p>6 SW switch<br/>KG-schakelaar<br/>Commutateur OC<br/>KW-Schalter<br/>Commutador OC</p> <p>7 FM switch<br/>FM-schakelaar<br/>Commutateur FM<br/>FM-Schalter<br/>Commutador FM</p> <p>8 AFC-switch<br/>AFR-schakelaar<br/>Commutateur de CAF<br/>AFR-Schalter<br/>Commutador CAF</p> | <p>SK-L<br/>+<br/>SK-M</p> <p>SK-K</p> <p>SK-F</p> |
|---|--|--|--|--|--|

IF (AM)	468 kHz	MF (AM)	FI (AM)	ZF (AM)	468 kHz	FI (AM)
IF (FM)	10,85 MHz	MF (FM)	FI (FM)	ZF (FM)	10,85 MHz	FI (FM)
Mains voltages	110 V - 127 V - 220 V - 240 V	Netzschnnungen	Tensions secteur	Netzspannungen	110 V - 127 V - 220 V - 240 V	Tensiones de red
Consumption (without signal)	42 W (220 V)	Verbruik (zonder der signaal)	Consommation (sans signal)	Verbrauch (ohne Signal)	42 W (220 V)	Consumo (sin señal)
Output	2,5 W	Uitgangsver- mogen	Puissance de sortie	Ausgangs- leistung	2,5 W	Tension de salida
Dimensions	548x180x165 mm	Afmetingen	Dimensions	Abmessungen	548x180x165 mm	Dimensiones

### Wave ranges - Golfgebieden - Gammes d'ondes - Wellenbereiche - Márgenes de ondas

LW-LG-GO-LW-OL	: 1166 - 2000 m ( 250 kHz - 160 kHz)
MW-MG-PO-MW-OM	: 187 - 545 m (1500 kHz - 600 kHz)
SW-KG-OC-KW-OC	: 24,2 - 51,7 m ( 11,7 MHz - 6,1 MHz)
FM-FM.FM-FM-FM	: 100 MHz - 87,5 MHz

### Valves - Buizen - Tubes - Röhren - Válvulas

B1 - ECC85	B5 - EL86
B2 - ECH81	B6 - EM84
B3 - EF89	LA1,2 - 8073D (6,3 V - 0,1 Amp.)
B4 - EBC81	

### Diodes

GR1 - B250 C100 td.
GR2 - OA79
GR3 - OA79
GR4 - BA102

CS1680

Index: CS822, CS1680-1684

SERVICE INFORMATION									
---------------------	--	--	--	--	--	--	--	--	--

JV/JD

Copyright reserved. Confidential information for Service Dealers.

4822 725 10025

Printed in Holland

Serv-o-mecum	Wave range Golfgebied Gamme d'ondes Wellenbereich Margen de ondas	Trimming point Trimpunt Point de réglage Trimpunkt Punto de ajuste	Signal Signaal Signal Signal Señal	Trim Afregefen Régler Abgleichen Ajustense	Indication Aanwijzing Indication Anzeige Indicación
E-a-3					
IF-MF-FI-ZF-FI	FM	100 Mc/s	1) 10,85 Mc/s via 1500 pF	2B3 2B2 2B1 4)	2 - 22 S18, S19 S7, S8 S24, S25 3) 5)
Repeat - Herhalen - Répéter - Wiederholen - Repñanse					
RF-HF-HF-HF-RF	FM	94 Mc/s	6)	S4, S5	Max. DV

Serv-o-mecum E-a-2

IF-MF-FI-ZF-FI	FM	100 Mc/s	10,85 Mc/s via 1500 pF	2B3 2B2 2B1 8)	7) S22 S18, S19 S7, S8 S24, S25 Max. DV 0 V DV
Repeat - Herhalen - Répéter - Wiederholen - Repñanse					
RF-HF-HF-HF-RF	FM	94 Mc/s	6)	S4, S5	Max. DV

Serv-o-mecum	Wave range Golfgebied Gamme d'ondes Wellenbereich Margen de ondas	Trimming point Trimpunt Point de réglage Trimpunkt Punto de ajuste	Signal Signaal Signal Signal Señal	Trim Afregefen Régler Abgleichen Ajustense	Indication Aanwijzing Indication Anzeige Indicación	
E-a-1						
IF-MF-FI-ZF-FI	MW-MG-PO-MW-OM	Max. capacitor	468 Mc/s - via 33000 pF	2B2	S27, 26, 21, 20 Max. output	
Repeat - Herhalen - Répéter - Wiederholen - Repñanse						
RF-HF-HF-HF-RF	MW-MG-PO-MW-OM	A	600 kc/s		S13, S9	
		B	1500 kc/s		C18, C19	
	LW-LG-GO-LW-OL	A	160 kc/s			C27
		B	250 kc/s			C13, S10
	SW-KG-OC-KW-OC	A	6,1 Mc/s			S16
		B	11,7 Mc/s			S12
Repeat - Herhalen - Répéter - Wiederholen - Repñanse						

\* Unless stated otherwise, signal has to be applied via a normal artificial aerial.  
Tenzij anders aangegeven, wordt het signaal toegevoerd via een normale kunstantenne.  
Sauf indication contraire, le signal est appliqué par l'intermédiaire d'une antenne fictive normale.  
Wenn nicht anders angegeben, wird das Signal über eine normale Kunstantenne zugeführt.  
A menos que se indique lo contrario, la señal es aplicada a través de una antena artificial normal.

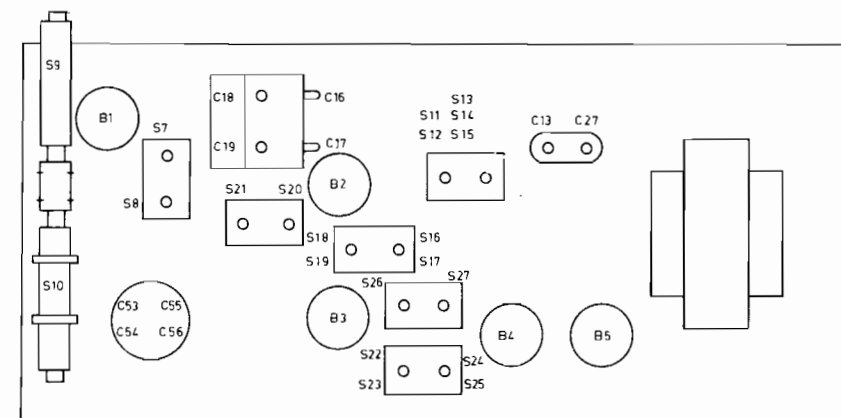

TRA 2416

CS822

S	31 28 29 30 33 36 35 3 2 34.																	37.	1. 2. 3.	S	
C		11.	22. 30					50. 38. 49. 26. 44.	24.	45.	25. 21.	40.	39.	22.	32. 55. 56.	53. 47. 36. 35.	3.	63. 9. 7. 2. 58. 8.		C	
C		48.		57.	51.	52.	46.	60. 27. 33. 62. 37. 43.	41.	14.	34. 20.	23. 33. 15.		42.	31.	54. 68. 13. 28.	12.	1. 62. 10.	5. 6. 4.	C	
R					48. 34. 32.	50. 30		21.	20. 23.		38. 18.		41.	10. 39.		52. 33. 33a.	36.	45.	46.	R	
R		24. 26.	25.			29.		28. 31.		42. 34.	43. 44.	35. 12. 16.		17.	15.	8. 12.	9.	7. 6. 14. 40. 22. 13. 5.	47.	4. 3.	R

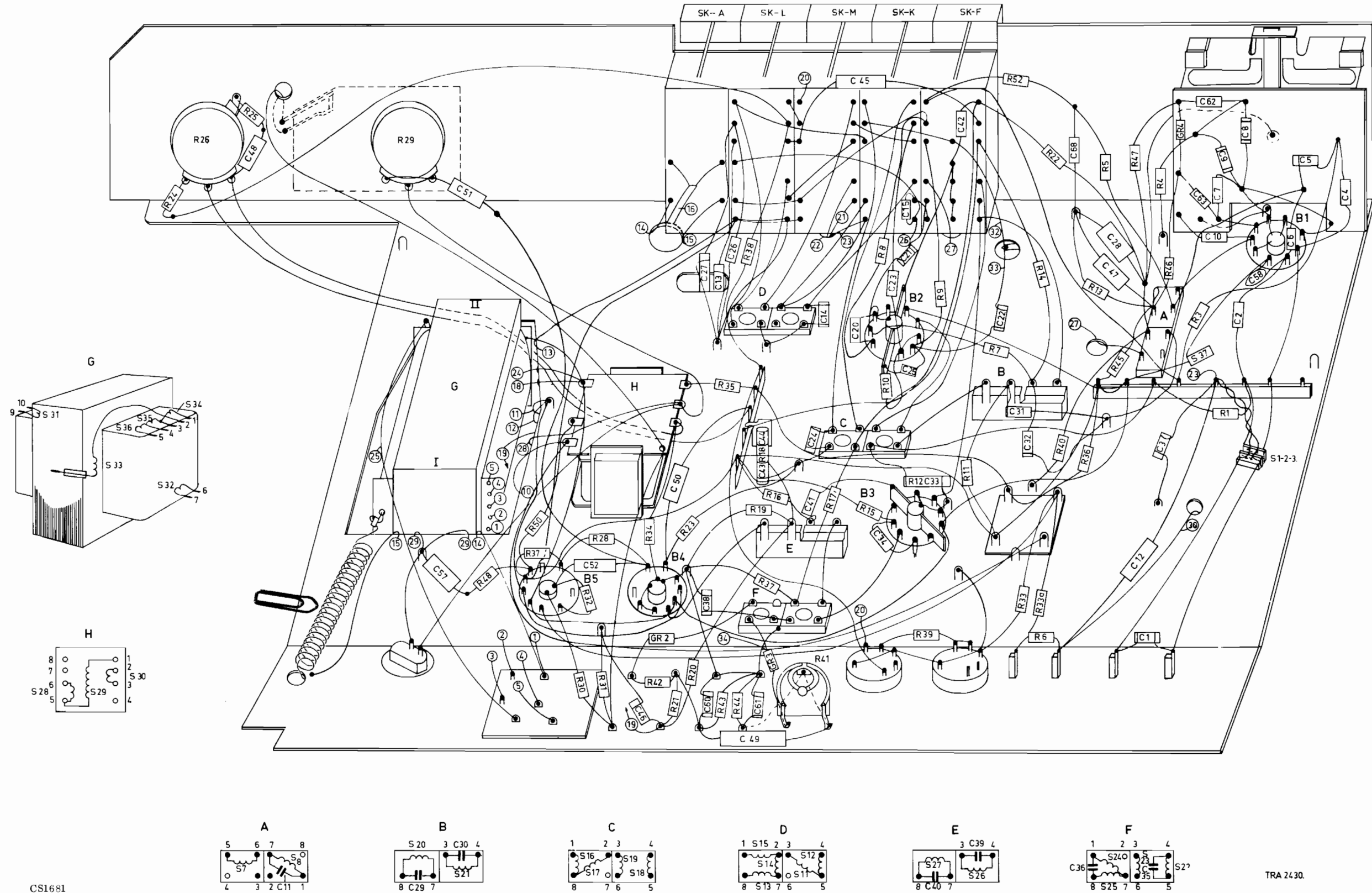



S	10	9	8.7	21.20	19.18.16.17.22.23.26.27.24.25.11.12.13.14.15.	S
C			53.54.55.56		19.17.18.16	C
R					13.27.	R
						26.
						27

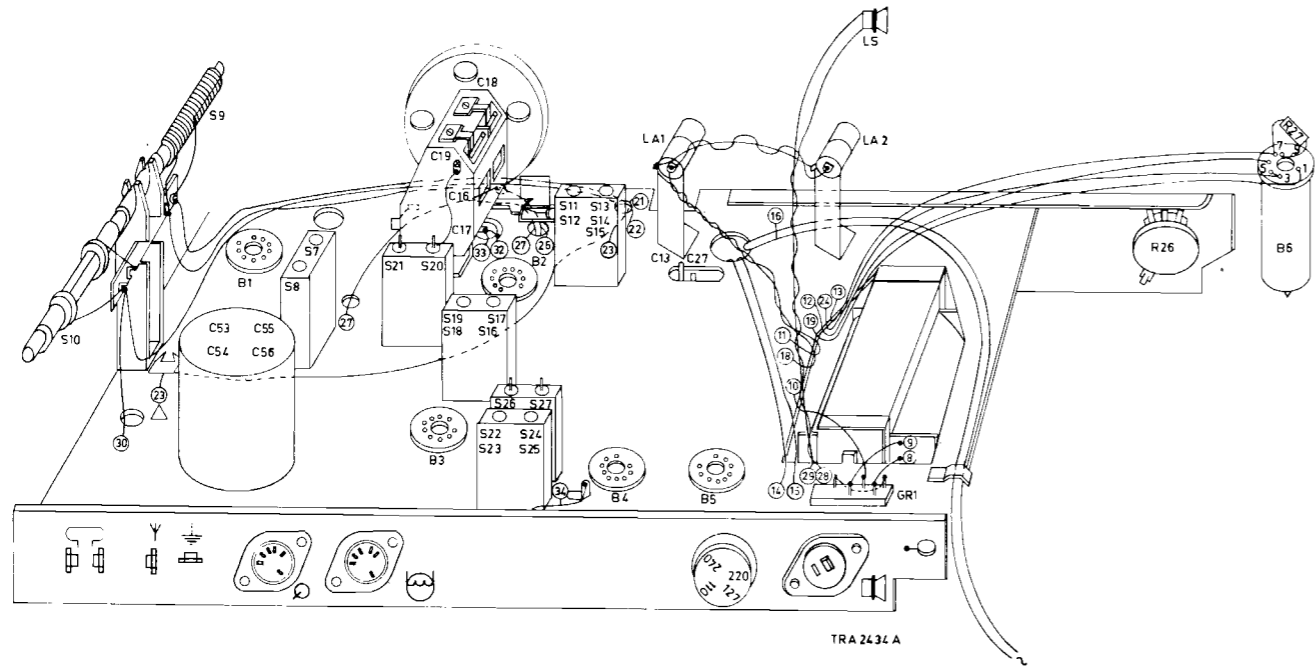

1. The signal to be applied is FM-modulated with a sweep of 20 kc/s.
2. Disconnect C49. Connect an oscilloscope across C60 via the accompanying network.
3. Adjust to max. height and symmetry of the S-curve.
4. Reconnect C49, short-circuit AFC and displace the network across C28.
5. Adjust to max. height and symmetry of the S-curve, then remove AFC short-circuit.
6. Apply signal to FM aerial socket and connect a digital voltmeter across C49.
7. Disconnect C49. Connect a voltmeter across C60.
8. Reconnect C49 and connect a voltmeter across C49.

1. Het toe te voeren signaal is FM-gemoduleerd met een zwaai van 20 kHz.
2. C49 losmaken. Sluit een oscillograaf aan over C60 via bijgaand netwerk.
3. Afregelen op max. hoogte en symmetrie van de S-kromme.
4. C49 vastmaken, AFR kortsluiten en netwerk verleggen over C28.
5. Afregelen op max. hoogte en symmetrie van de S-kromme, daarna AFR kortsluiting verwijderen.
6. Signaal toevoeren aan FM-antennebus en een DV aansluiten over C49.
7. C49 losmaken. DV aansluiten over C60.
8. C49 vastmaken en DV aansluiten over C49.

1. Le signal à appliquer est modulé en fréquence avec une excursion de 20 kHz.
2. Détacher C49. Raccorder un oscilloscope à travers C60 par l'intermédiaire du réseau joint.
3. Régler sur hauteur et symétrie maximales de la courbe S.
4. Fixer C49, court-circuiter CAF et déplacer le réseau à travers C28.
5. Régler sur hauteur et symétrie maximales de la courbe S, retirer ensuite le court-circuit CAF.
6. Appliquer un signal à la douille d'antenne FM et raccorder un voltmètre à diode à travers C49.
7. Détacher C49. Raccorder le voltmètre à diode à travers C60.
8. Fixer C49 et raccorder le voltmètre à diode à travers C49.

1. Das zuzuführende Signal ist mit einem Hub von 20 kHz moduliert.
2. C49 lösen. Einen Oszillografen über beigefügtes Netzwerk an C60 anschliessen.
3. Auf maximale Höhe und Symmetrie der S-Kurve abgleichen.
4. C49 befestigen, AFR kurzschliessen und Netzwerk an C28 verlegen.
5. Auf maximale Höhe und Symmetrie der S-Kurve abgleichen; danach AFR Kurschluss entfernen.
6. Signal der FM-Antennenbuchse zuführen und ein Diodevoltmeter an C49 anschliessen.
7. C49 lösen. Diodevoltmeter an C60 anschliessen.
8. C49 befestigen und Diodevoltmeter an C60 anschliessen.

1. La señal a aplicar está modulada en frecuencia con una excursión de 20 kHz.
2. Soltar C49. Conectar un oscilógrafo en bornes de C60 a través del circuito adjunto.
3. Ajustar a la altura y simetría máximas de la curva S.
4. Fijar C49, cortocircuitar el CAF y desplazar el circuito a los bornes de C28.
5. Ajustar a la altura y simetría máximas de la curva S; luego quitar el cortocircuito del CAF.
6. Aplicar una señal al enchufe de antena de FM y conectar un voltmetro a diodo en bornes de C49.
7. Soltar C49. Conectar el voltmetro a diodo en bornes de C60.
8. Fijar C49 y conectar el voltmetro a diodo en bornes de C49.

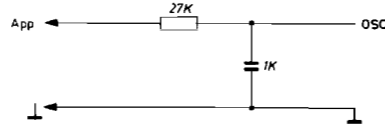

Cabinet (palisander) Cabinet (teak) Plug (tape rec. + rec. player) Socket (tape rec. + rec. player) Rear panel	4822 425 60048 4822 425 60047 4822 264 40023 4822 267 40039 4822 435 30024	Gehäuse (palisander) Gehäuse (teak) Stecker (Recorder + TA) Gegenstecker (Recorder+TA) Rückseite	4822 425 60048 4822 425 60047 4822 264 40023 4822 267 40039 4822 435 30024	Mueble (palisandro) Mueble (teca) Clavija (magnetófono+ tocadiscos) Enchufe (magnetófono+tocadiscos) Panel posterior.
Dial Screw fix. dial Knob AM, volume Knob FM, tuning Push button	4822 333 60085 4822 502 10713 4822 413 40294 4822 413 50536 4822 410 20447	Skala Schraube Bef. Skala Knopf AM, Lautstärke Knopf FM, Abstimmung Drucktaste	4822 333 60085 4822 502 10713 4822 413 40294 4822 413 50536 4822 410 20447	Cuadrante Tornillo fij. cuadrante Botón AM, volumen Botón FM, sintonía Pulsador
Knob, tone Screen behind scale Locking speed tuning	4822 413 40293 4822 480 30044 4822 450 80139	Knopf, Ton Platte hinter Skala Memo-Abstimmung Nocken	4822 413 40293 4822 480 30044 4822 450 80139	Botón, tono Placa detrás del cuadrante Aguja para sintonización rápida
FM unit Lamp holder	4822 210 10114 4822 255 10007	FM-Einheit Lampenfassung	4822 210 10114 4822 255 10007	Unidad de FM Porta lámparas
Push button unit Rotor (plastic) for tone control	4822 276 50092 4822 532 20316	Druckstasteneinheit Plastikrotor für Tonregelung	4822 276 50092 4822 532 20316	Unidad de pulsadores Rotor (plástico) para regulación de tono
Voltage adapter Pulley	4822 272 10015 4822 528 80241	Spannungswähler Rolle	4822 272 10015 4822 528 80241	Selector de tensión Polea
Aerial coil Antennenspoel Bobine d'antene Antennenspule Bobina de antena	4822 158 10049	Aerial coil SW Antennenspoel KG Bobine d'antenne OC Antennenspule KW Bobina de antena OC	4822 156 70014	IF-AM coil MF-AM spoel Bobine FI, AM ZF-Spule, AM Bobina FI, AM
Oscillator coil FM Oscillatorspoel FM Bobine oscillatrice FM Oscillatorspule FM Bobina de oscilador FM	4822 157 50313	Oscillator coil SW Oscillatorspoel KG Bobine d'antenne OC Antennenspule KW Bobina de antena OC	4822 158 60192	Output transformer Uitgangstransformator Transformateur de sortie Ausgangstransformator Transformador de salida
IF-FM coil MF-FM spoel Bobine FI, FM ZF-Spule, FM Bobina FI, FM	4822 153 90015	IF-AM coil MF-AM spoel Bobine FI, AM ZF-Spule, AM Bobina FI, AM	4822 153 20098	Mains transformer Netransformator Transformateur secteur Netztransformator Transformador de red
Ferroceptor MW-LW Ferroceptor MG-LG Ferroceptor PO-GO Ferroceptor MW-LW Ferroceptor OM-OL	4822 158 60191	FM detection coil FM-detectiespoel Bobine de détection FM FM-Detektorspule Bobina de detección FM	4822 153 70011	Unidad de pulsadores Rotor (plástico) para regulación de tono Selector de tensión Polea
GR1 LA1 S38	4822 130 50228 4822 134 40005 4822 240 50007	4822 113 30007 4822 101 10063 4822 125 20009	C33-R12 C43.44-R18 C47.49 C53...C56	4822 111 80061 4822 111 80025 4822 124 20098 4822 124 30061